

NEXXT MATRIXX[®] Technology

STRUXXURE[®]-A Integration

Intraoperative Flexibility



NEXXT MATRIXX®

3D Printed Porous Titanium

10X

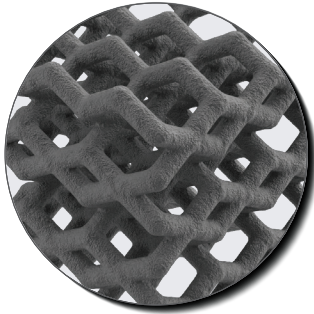

Systematic Titanium
PORES

300X

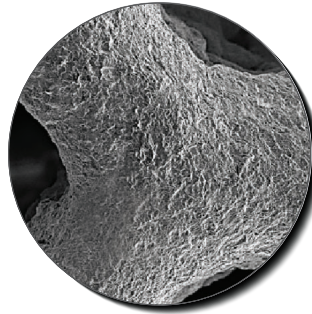

Uncompromising
MACROSURFACE

10,000X



7µm Surface
MICROSURFACE

Pillars of NEXXT MATRIXX® Technology:

1. 7µm surface roughness designed to increase osteoblast differentiation, production of angiogenic factors, and surface osteointegration.^{2,3,6}
2. Varied pore array of 300, 500, and 700µm designed to support vascularization and osteogenesis.^{1,4,5}
3. 75% Porous, open titanium architecture developed for greater surface area and nutrient exchange, leading to increased volume for potential boney in-growth.^{4,5,6}
4. Modulus of elasticity engineered to be comparable to PEEK devices leading to a more physiological product.⁶
5. 700µm A/P and lateral lattice geometry designed to provide robust radiographic imaging unimpeded by reducing overall titanium material and device density.⁶

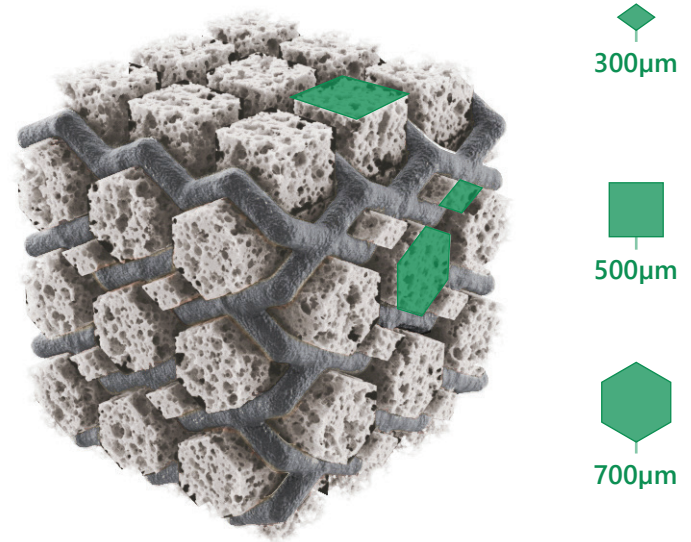

Image above used to illustrate available volume for bony ingrowth.

Studies referenced for the foundational design of NEXXT MATRIXX®:

1. Karageorgiou V, Kaplan D. Porosity of 3D biomaterial scaffolds and osteogenesis. *Biomaterials*. 2005;26(27):5474–91.
2. Olivares-Navarrete R, Hyzy SL, Slosar PJ et al. Implant materials generate different peri-implant inflammatory factors: poly-ether-ether-ketone promotes fibrosis and microtextured titanium promotes osteogenic factors. *Spine*. 2015;40(6):399–404.
3. Olivares-Navarrete R, Hyzy SL, Gittens RA, et al. Rough titanium alloys regulate osteoblast production of angiogenic factors. *Spine J*. 2013;13(11):1563–70.
4. Ponader S, von Wilmowsky C, Widenmayer M, et al. In vivo performance of selective electron beam-melted ti-6al-4v structures. *J Biomed Mater Res A* 2010;92A:56–62
5. Li JP, Habibovic P, et al.: Bone ingrowth in porous titanium implants produced by 3D fiber deposition. *Biomaterials* 28:2810, 2007.
6. Data on file at Nexxt Spine, LLC.

CAGE FEATURES

- A** Bulleted nose design simplifies insertion in collapsed degenerative discs without compromising the apophyseal rim.
- B** Anatomically matched profile designed to provide appropriate endplate coverage and placement on apophyseal rim for stability.
- C** Ample graft window balanced with lattice landscape designed to create environment for bone growth and is based on published data.
- D** Implant compatibility with STRUXXURE[®]-A Plate System for single position procedural solution.
- E** Cephalad/Caudal symmetry provides intraoperative flexibility for additional left or right insertion at either 12° and 25°.

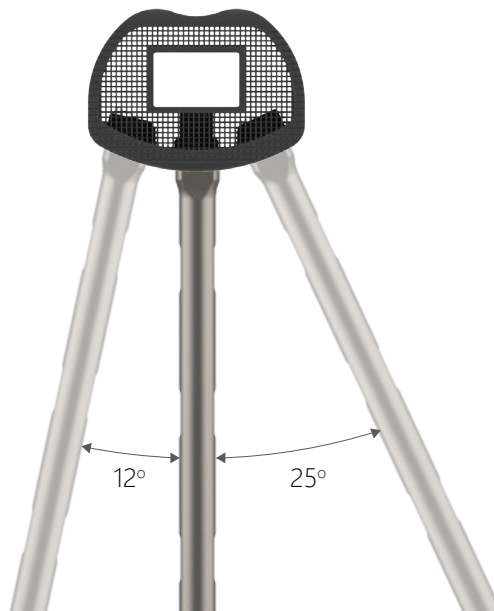
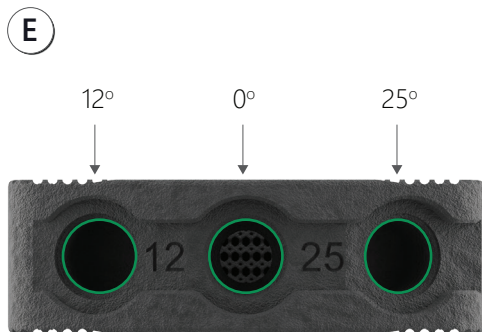
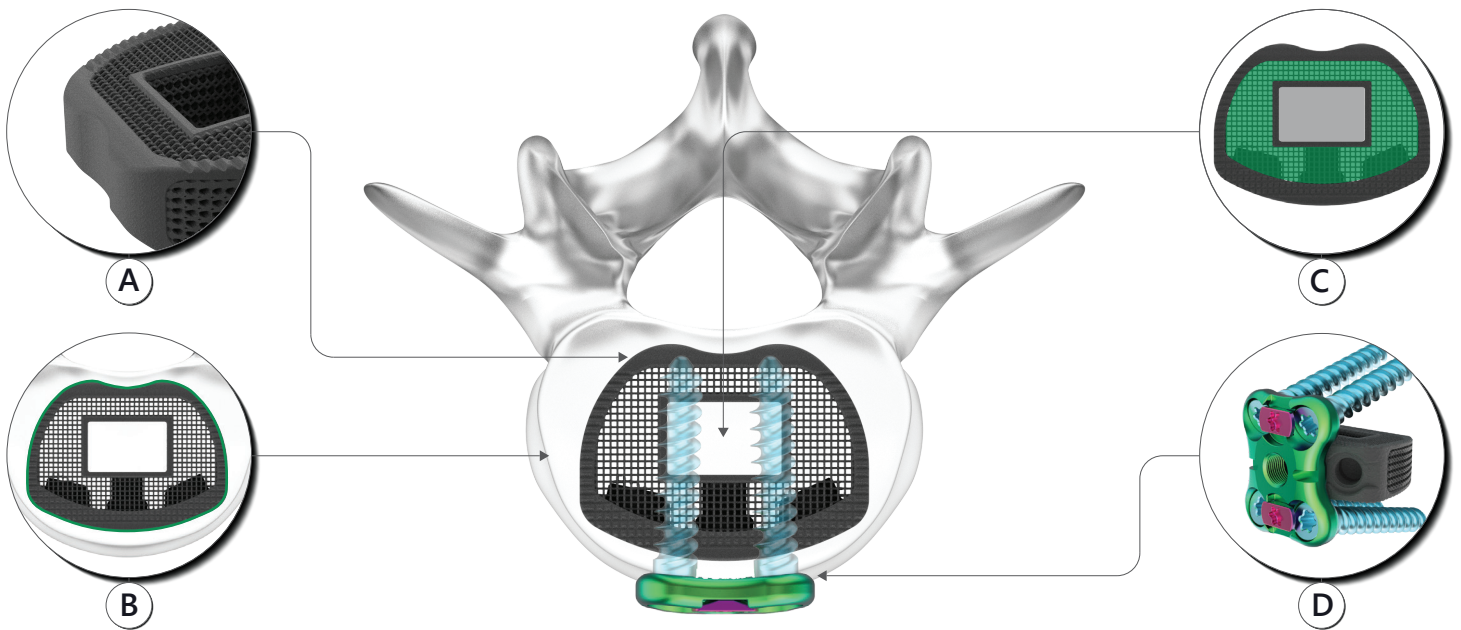

CAGE SPECS

Footprints

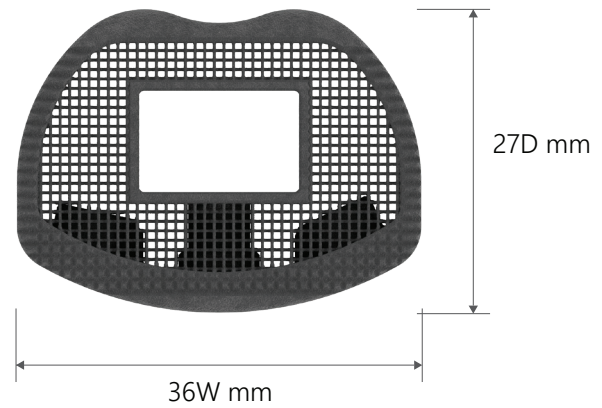
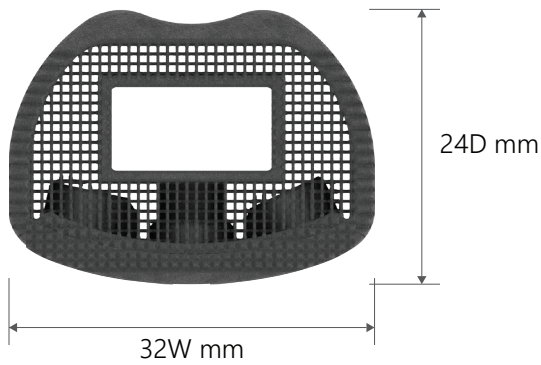

Lordoses

8°, 14°, and 20°

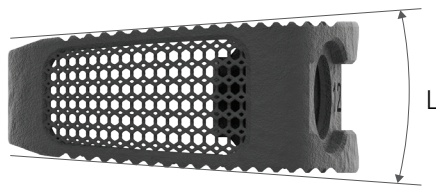

Heights

8, 10, 12, 14, 16, 18, and 20mm

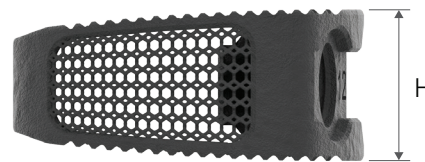

Size Offering

Depth x Width x Height x Lordosis

Key: Standard Made to Order

| D | W | H | 8° | 14° | 20° |
|----|----|----|-------------------------------------|-------------------------------------|-------------------------------------|
| 24 | 32 | 08 | <input checked="" type="checkbox"/> | | |
| | | 10 | <input checked="" type="checkbox"/> | <input checked="" type="checkbox"/> | |
| | | 12 | <input checked="" type="checkbox"/> | <input checked="" type="checkbox"/> | <input checked="" type="checkbox"/> |
| | | 14 | <input checked="" type="checkbox"/> | <input checked="" type="checkbox"/> | <input checked="" type="checkbox"/> |
| | | 16 | <input checked="" type="checkbox"/> | <input checked="" type="checkbox"/> | <input checked="" type="checkbox"/> |
| | | 18 | <input checked="" type="checkbox"/> | <input checked="" type="checkbox"/> | <input checked="" type="checkbox"/> |
| 27 | 36 | 08 | <input checked="" type="checkbox"/> | | |
| | | 10 | <input checked="" type="checkbox"/> | <input checked="" type="checkbox"/> | |
| | | 12 | <input checked="" type="checkbox"/> | <input checked="" type="checkbox"/> | <input checked="" type="checkbox"/> |
| | | 14 | <input checked="" type="checkbox"/> | <input checked="" type="checkbox"/> | <input checked="" type="checkbox"/> |
| | | 16 | <input checked="" type="checkbox"/> | <input checked="" type="checkbox"/> | <input checked="" type="checkbox"/> |
| | | 18 | <input checked="" type="checkbox"/> | <input checked="" type="checkbox"/> | <input checked="" type="checkbox"/> |
| | | 20 | <input type="checkbox"/> | <input checked="" type="checkbox"/> | <input checked="" type="checkbox"/> |



Nexxt Spine, LLC
 14425 Bergen Blvd, Suite B
 Noblesville, IN 46060
 (317)-436-7801
 Info@NexxtSpine.com
 NexxtSpine.com

For indications, contraindications, warnings, precautions, potential adverse effects and patient counselling information, see the package insert or contact your local representative; visit NexxtSpine.com for additional product information.

All rights reserved. All content herein is protected by copyright, trademarks and other intellectual property rights owned by Nexxt Spine, LLC and must not be redistributed, duplicated or disclosed, in whole or in part, without the expressed written consent of Nexxt Spine, LLC. This material is intended for health care professionals, the Nexxt Spine sales force and authorized representatives. Distribution to any other recipient is prohibited.