

OPERATIVE TECHNIQUE

Forza™

Spacer System

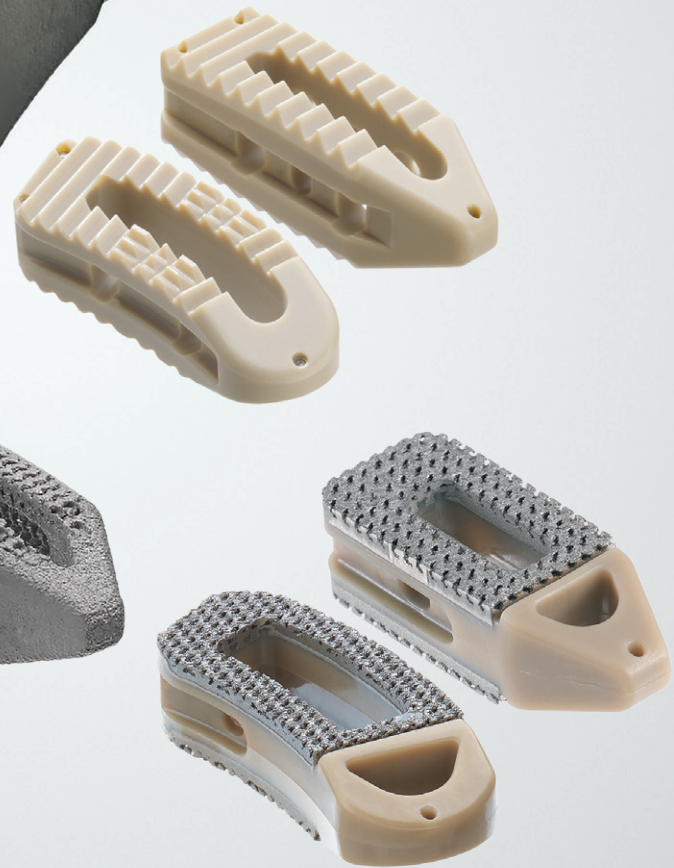
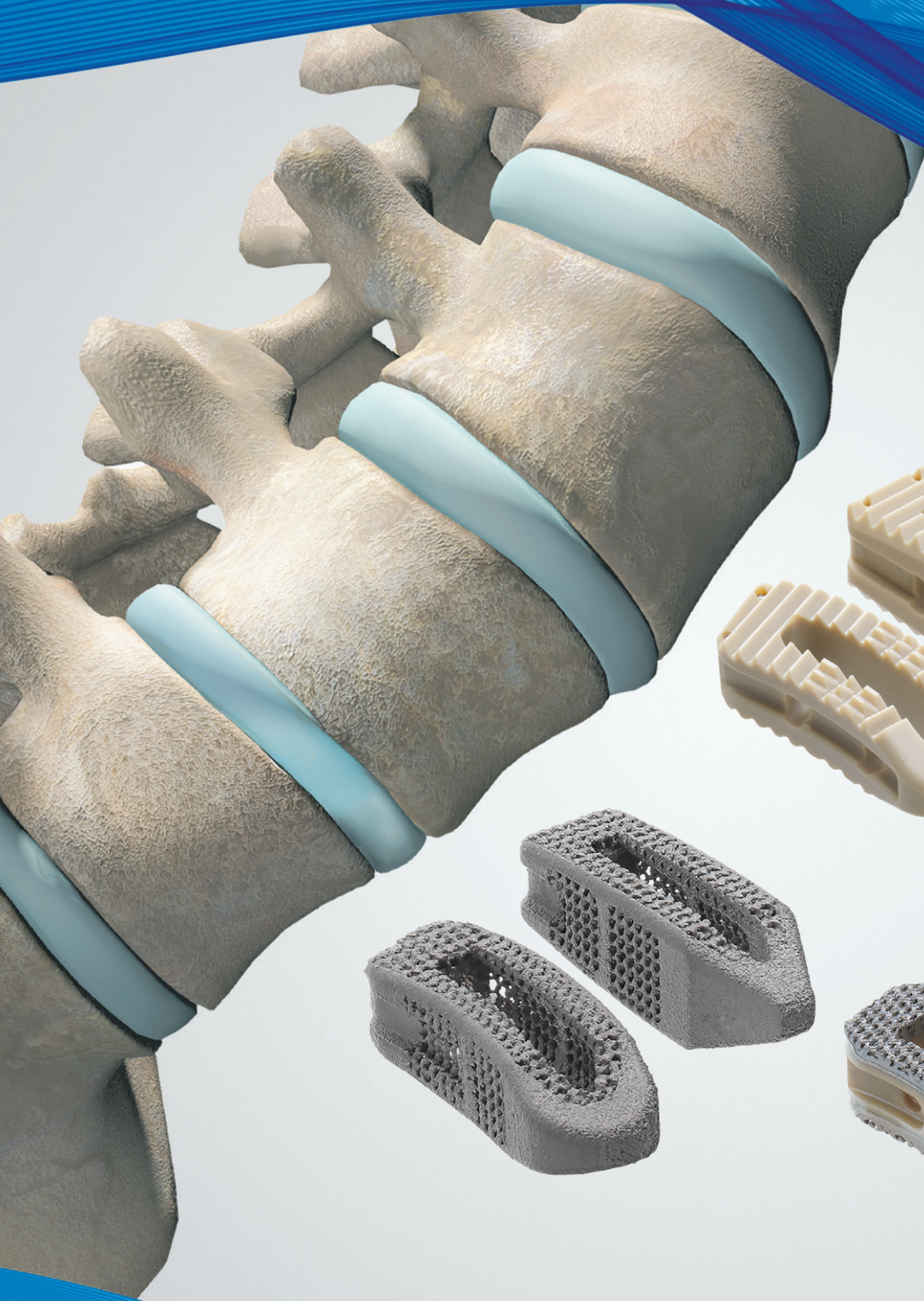

Table of Contents

1	Introduction
2	Operative Technique
12	Instrument List and Part Numbers
18	Implants List, Part Numbers and Graft Volumes
30	Modular Implant Inserter Disassembly and Assembly Instructions

The surgical technique shown is for illustrative purposes only. The technique(s) actually employed in each case will always depend upon the medical judgment of the surgeon exercised before and during surgery as to the best mode of treatment for each patient. Please see the Instructions For Use for the complete list of indications, warnings, precautions, and other important medical information.

INTRODUCTION

The Forza Implants System has been designed to help optimize Transforaminal Lumbar Interbody Fusion (TLIF) and Posterior Lumbar Interbody Fusion (PLIF) procedures with surgeon designed implants and instruments. The Forza Implants System offers implants manufactured from either PEEK, Titanium (Ti), or PEEK Titanium Composite (PTC) materials.

DESIGN ADVANTAGES

Forza™ PEEK	Forza™ PTC	Forza™ Ti
Large center opening for packing bone grafting material		
Bullethead nose to assist with distraction		
Threaded Connection to the implant inserter with rail grooves for a secure hold that is firm enough for an insert and rotate technique	PEEK Core to obtain imaging properties while assessing them	Functional gradient porous structure with 80% porosity at the midline of the implant to allow for increased fluoroscopic visualization
Chamfered edges for easier rotation with the straight cage	3D porous titanium with macro, micro, and nano-scale surface features	
	The nano-scale surface has been shown to increase proliferation and alkaline phosphatase activity (an early osteogenic differentiation marker) in human stem cells in vitro ¹	
Aggressive anti-migration ribs for resisting implant migration	3D-printed titanium endplates with 400 micron pores and 50% porosity are designed to help facilitate bone ingrowth ²	
	The endplates consist of interconnected gyroid structures analogous in form to trabecular bone, which provide an open porous environment	
Vertical tantalum marker 1mm from the edge for clear in-situ implant positioning		

Special features of the Forza Implants and Instruments include:

- One set of instrumentation can be used with Forza PEEK, Ti and PTC implants
- Threaded inserters with rail features for secure connection to the implant
- Implant Inserters with different handle angle locations to match surgeon preference
- MIS Inserter for improved visualization in tight spaces
- Monolithic implant trials for speed and efficiency

STERILIZATION

Forza PEEK, Ti, and PTC Implants are provided in a sterile package. Carefully confirm the implant size that you desire from the outside label prior to opening the box or inside trays. The implants are packaged in a double-tray with a peel back lid for easy transfer into the sterile field. If the implant is opened and not used, the implant MAY NOT be sterilized and used again. Forza instruments are utilized with either the Forza PEEK, Ti, or PTC implants. Forza instruments are provided non sterile and require cleaning and sterilization prior to each use. Clean and sterilize the Forza instruments as directed by the Instructions for Use (IFU). In order to mitigate tears or ripping of the sterile wrapping, please do not drag the sterile cases while wrapped.

¹ In vitro performance may not be representative of clinical performance

² As suggested in an in-vivo lumbar spinal fusion model

1. DISCECTOMY

Remove the disc using Pituitary Rongeurs and Curettes such as those provided in the Forza Discectomy Case with minimal or no nerve root retraction. Both Cup and Ring Curettes are provided in the Forza Discectomy Set. Forza Ring Curettes are designed for linear scraping and not for rotating while in the intervertebral body space.

If there is significant disc space collapse, completion of the discectomy may not be possible until distraction of the disc space takes place.

(Fig. 1a & 1b)

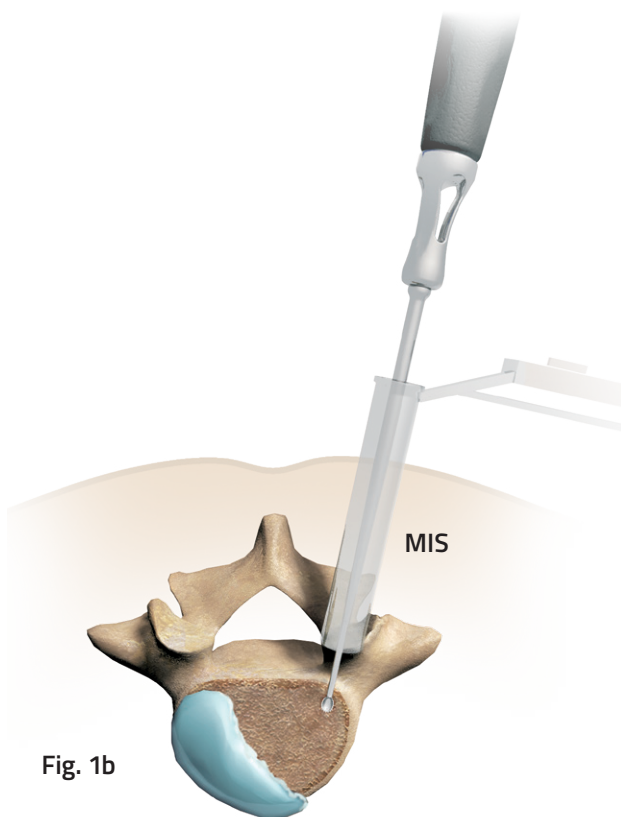
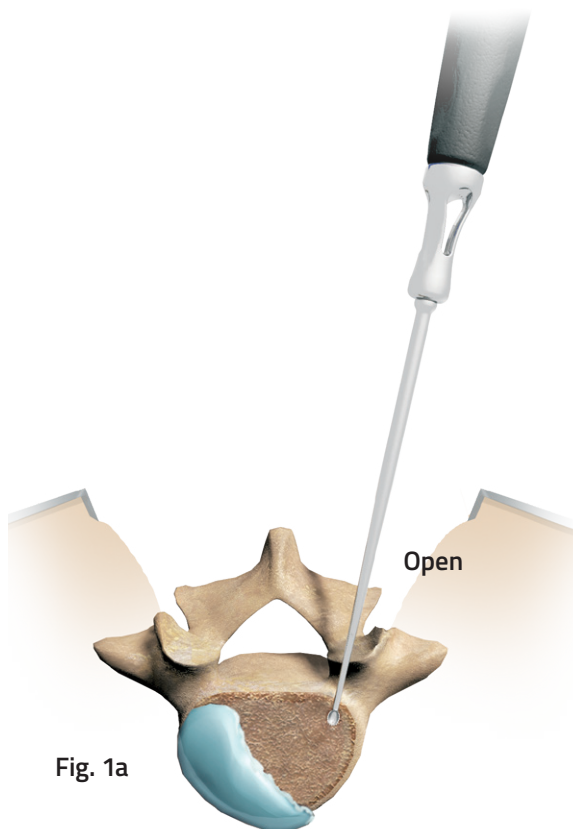

2. DISC SPACE PREPARATION

Distract the disc space sequentially using distractors such as the Paddle Distractors provided in the Forza Discectomy Case. The size indicated on the Forza Paddle Distractors matches the height of the Forza Trial and Forza implant. The heights are clearly indicated on the instruments and the shafts are color coded. However, colors are variable, therefore it is imperative to confirm the size with the numbers on the instruments.

NOTE: Although color coding may be a useful tool, colors may vary. It is therefore, imperative to confirm the size with the numbers on the instrument.

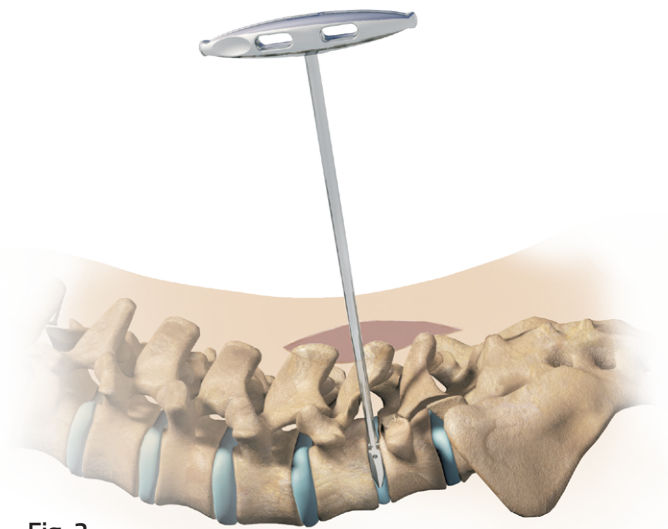
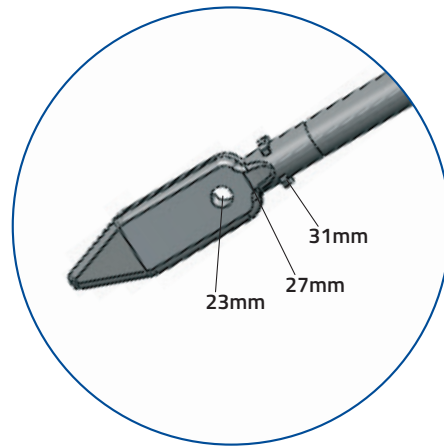

Fig. 2

HEIGHTS	COLORS
6mm	BRONZE
7mm	BLUE
8mm	GREEN
9mm	GOLD
10mm	DARK BLUE
11mm	MAGENTA
12mm	SEAFOAM
13mm	GRAY
14mm	TEAL
15mm	PURPLE
16mm	COPPER OR PINK



The most commonly used lengths associated with the Forza implants are indicated by the circle (23mm), the end of the body (27mm), and the small protrusions on the neck (31mm). Each of these length indicators are visible with fluoroscopy.

Insert the Paddle Distractor with the sides touching the endplates and turn to distract. If necessary, repeat sequentially with additional sizes until desired disc space height and foraminal size is obtained. **(Fig. 2)**

3. DISC SPACE PREPARATION

Rotating Cutters are provided in sequential heights to remove any additional disc and to prepare the endplates. **(Fig. 3)** The Cutters in the Forza Discectomy Set are designed for safety with a blunt tip and cutting sides.

The color coded rotating sleeve is designed for use with two hands for a smooth cutting motion. The three most common Forza Implant lengths, 23mm, 27mm, and 31mm, are indicated on the Rotating Cutters with numbers and bars, and small holes that can be seen by lateral fluoroscopy when the instrument is directly straight such as in a PLIF position. The heights are clearly indicated on the instruments and the rotating sleeves are color coded. As with the Forza Distractors, colors are variable, therefore it is imperative to confirm the size with the numbers on the instrument. See previous page for the height/color chart.

Choices of Rasps, Curettes, and other additional instruments are provided in the Forza Discectomy set for disc removal and end plate preparation.

The Ring Curettes are designed for linear scraping and not for rotating while in the intervertebral body space.

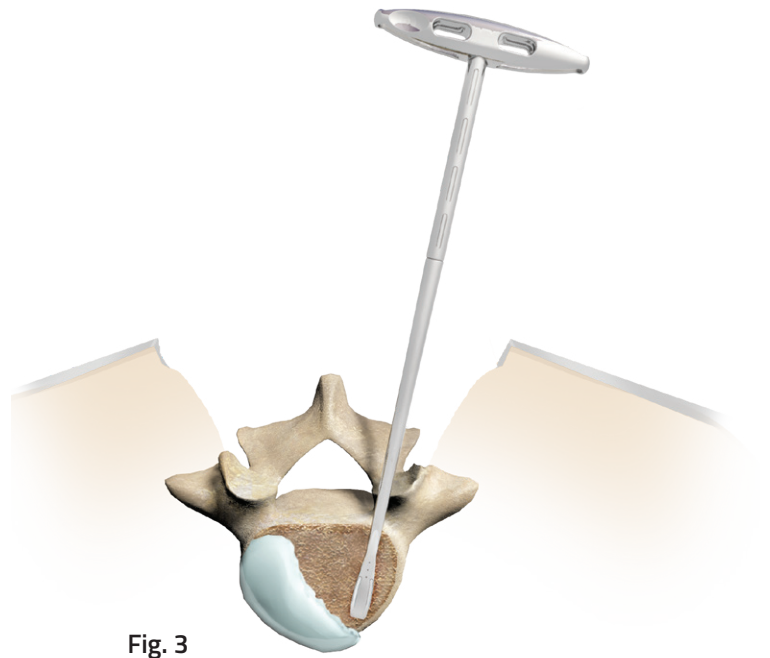
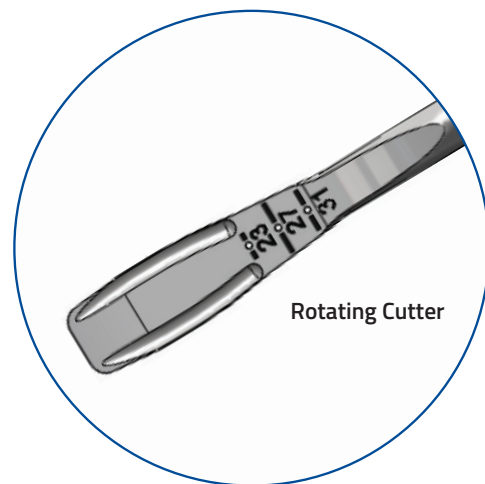

Fig. 3



4. TRIAL SIZING

Forza Trials are 9mm wide and 27mm long with length indicators that are visible with fluoroscopy. The small hole indicates 23mm. The end of the trial body is 27mm. The ring indicates 31mm. Also to assist with implant positioning there are lines on the shaft of the Trials for visual alignment once in situ.

Insert the Forza trials sequentially by height size until the desired disc space height is obtained. Use A/P and lateral fluoroscopy for placement and trajectory. **(Fig. 4)**

A Slap Hammer is provided in the Forza instrument set for assisting with pulling the Forza Trial out of the disc space. Holding the tip of the Trial distally, attach the Slap Hammer to the Trial Handle aligning and sliding the prongs to the slot on the Trial Handle, and turning the Slap Hammer clockwise until it is locked.

Remove the Slap Hammer holding the tip of the Trial distally, pulling the two prongs up, turning the Slap Hammer counterclockwise to unlock, and sliding it off from the Trial.

Once the desired Forza Trial size is determined, match the size with the appropriate Forza implant. The heights of the Forza implants are color coded with a square on the box that contains the sealed tray. These color coded squares correspond to the chart on page 3 and match the Distractors and Rotating Cutters in the Forza Discectomy Set.

NOTE: Although color coding may be a useful tool, as with the colors on the instruments, colors may vary. Please confirm the size on the label.

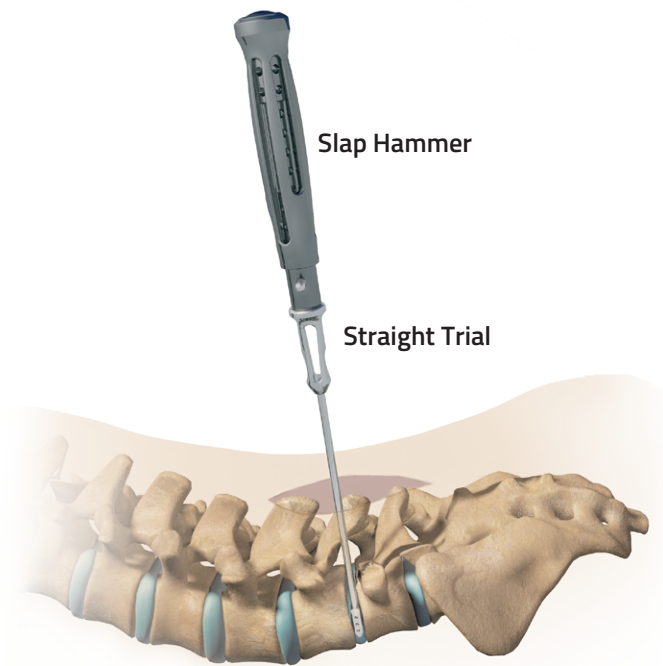

Fig. 4



5. FORZA IMPLANT INSERTION

Modular Implant Inserter

Forza PEEK, Ti, and PTC implants are provided sterile. Choose the desired implants. Carefully check the label for the type and size of the implants, as well the expiration date to confirm that the package has not expired. If a implants is opened by mistake it cannot be re-sterilized.

Prior to attaching the Modular Implant Inserter to the Forza PEEK, Ti, or PTC implants, add autograft and /or allograft comprised of cancellous and/ or corticocancellous bone graft into the implants opening(s) as desired.

The Modular Implant Inserter may require assembly or disassembly prior to use. See page 28 for complete instructions.

Due to the modularity, options for the Modular Implant Inserter include four (4) different shafts and three (3) handle angle positions. The shafts are for straight and curved implantss in 9mm and 11mm widths. The handle angle options are 180°, 90°, and 45°. (Fig. 5)

When using the Modular Implant Inserter in the 90° or 45° position there is an option to use the Impact Cap for impacting with a mallet. Holding the Modular Implant Inserter distally, attach the Impact Cap to the Modular Implant Inserter aligning and sliding the prongs to the slot on the Modular Implant Inserter, and turning the Impact Cap clockwise until it is locked.

To remove the Impact Cap hold the tip of the Modular Implant Inserter distally, pull up the two prongs, turn the Impact Cap counter-clockwise, and slide it off of the Modular Implant Inserter.

The Modular Implant Inserter can be used alone or with the Universal Handle. A strike plate is provided on the Universal Handle for impacting with a mallet. To assemble the Handle to the Modular Implant Inserter mate the Handle with the piston or connection. Use two fingers around the metal top of the Handle and push down the plunger like a syringe while turning the Handle clockwise until firmly attached.

Optionally place autograft or allograft comprised of cancellous and/or corticocancellous bone graft anteriorly in the disc space prior to inserting the implant and contralaterally once the implant is inserted.

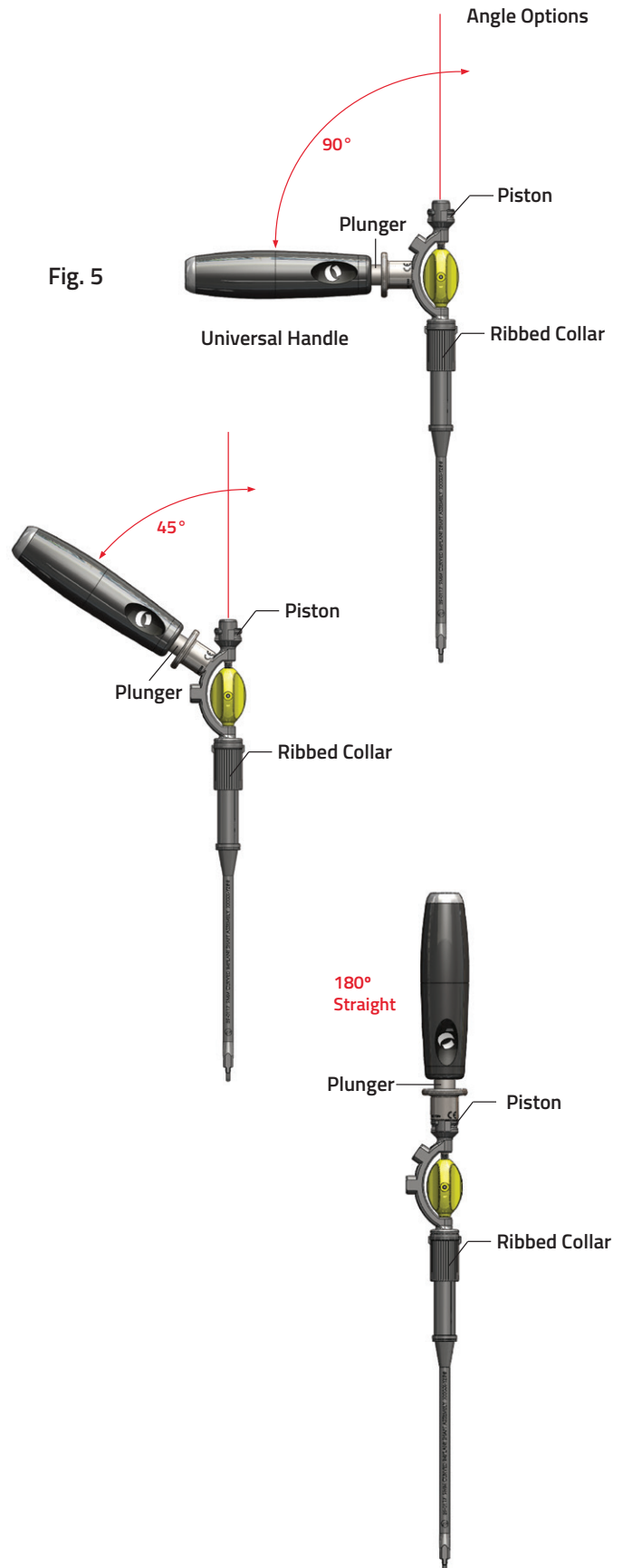

To place the implant in situ, attach the appropriately sized Forza PEEK, Ti, or PTC implant to the Modular Implant Inserter by aligning the implant grooves with the Modular Implant Inserter rails then turning the center gold knob clockwise until the implant is firmly attached. The rails on the Modular Implant Inserter hold the implants to provide additional stability for the implant connection. The straight implant has grooves on both sides to engage with the Straight Shaft of the Modular Implant Inserter to add stability when rotating.* The curved implant has a longer posterior groove to engage with the corresponding Curved Shaft of the Modular Implant Inserter. This longer groove and rail interface assists with steering the implants in situ.

To disengage the implant, turn the gold knob counter-clockwise until it is disengaged.

If pulling back the implant posteriorly is desired, the Slap Hammer is available in the Forza Instrument Set. To attach the Slap Hammer to the Modular Implant Inserter align and slide the prongs to the slot on the Modular Implant Inserter and turning the Slap Hammer clockwise until it is locked. Please note that the Slap Hammer can only be oriented in the 180° position.

Remove the Slap Hammer by holding the tip of the Modular Implant Inserter distally, pull up the two prongs, turn the Slap Hammer counter-clockwise, and slide it off.

MIS Inserter (Fig. 7)

The MIS Inserter is available for a simple insertion of the curved or straight implants either with an open or a MIS technique. Connection is achieved by firmly attaching the implant to the threaded connection and turning the instrument clockwise 3 full rotations. Over tightening may cause binding of the implant and then difficulty with releasing it when disengaging. When using this instrument, do not lever it nor use heavy force.

To disengage the implant, turn the instrument counter-clockwise until it is disengaged.

Optional Monolithic Straight Implant Inserter

Another option for inserting the straight implant is the Monolithic Straight Implant Inserter. (Fig. 8) This Inserter is designed with a T-Handle attached for easier rotation. Connection to the Forza straight implant is achieved by aligning the implant grooves with the rails on the Inserter, then turning the center knob clockwise. The rails are the same as on the Modular Implant Inserter and serve the same purpose, providing additional stability, particularly with rotation.*

To disengage the straight implant, turn the center knob counter-clockwise until it is disengaged.

***NOTE:** The Forza PEEK straight implants may be rotated after insertion with either the Modular Implant Inserter or the Monolithic Straight Implant Inserter. The Forza PTC and Forza Ti implants are not intended to be rotated after insertion.

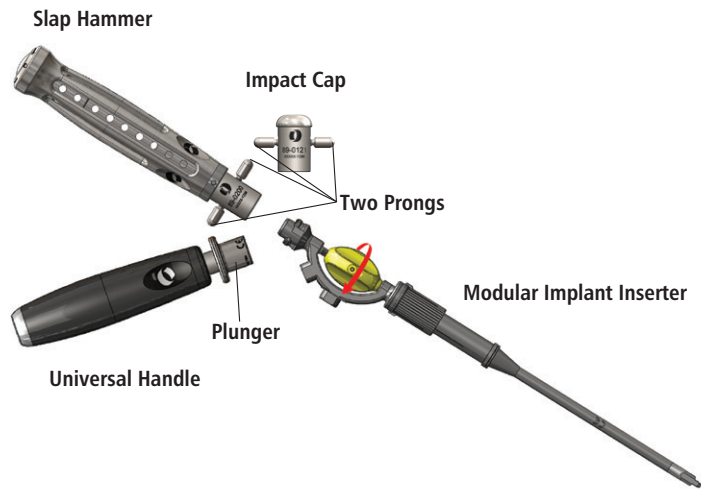

Fig. 6

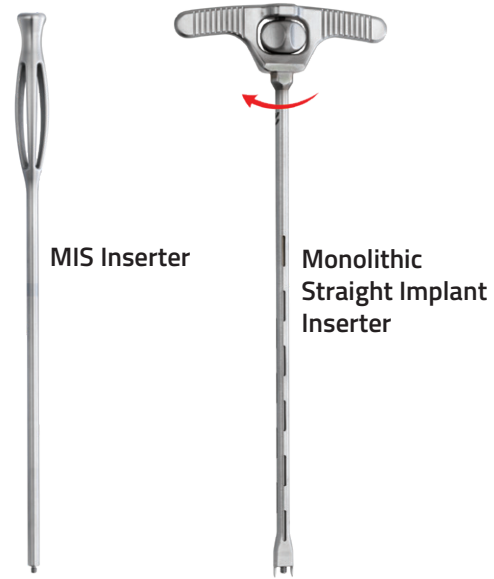

Fig. 7

Fig. 8

5. FORZA IMPLANT INSERTION (CONT.)

Insert the desired Forza PEEK, Ti, or PTC implant into the intervertebral body space with one of the Forza Inserter choices and impact the Inserter with a mallet to initiate positioning. Verify the position of the implant with fluoroscopy. **(Fig. 9a)**

Implant Positioning

Use a Tamp to push the Forza PEEK, Forza Ti or PTC implant into the desired position. **(Fig. 9b)** A variety of Tamps are provided in the Forza Instrument set. **(Fig. 10)**

Straight Forza Tamps are specific to the width of the implant with side rails for added control. To use, align the fork of the Tamp with the implant grooves and impact to push the implant into the desired position. Once implant positioning is completed, pull out the Tamp.

The Corner Tamp is designed to assist with turning the implant. To use, align the grooves of the Corner Tamp with the implant hole or corner edge and impact to push and/or steer the implant.

Fluoroscopy is recommended to confirm positioning. Once positioning is completed, pull out the Tamp.



Fig. 9a

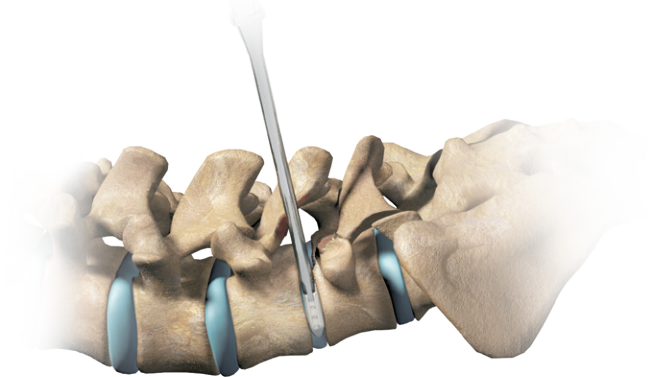

Fig. 9b

The optional Articulating Tamp is designed to assist with turning the Forza PEEK, Ti, or PTC Curved Implant in TLIF procedures when not using MIS tube retractors. Prior to sterilizing, be sure to loosen the gears by turning the center knob counter-clockwise and confirming that the gears are separated and loosened.

Please note when using this instrument it is recommended to leave the Forza PEEK, Ti, or PTC implant somewhat proud and slightly protruding posteriorly from the disc space when disengaging the implant inserter. This will effectively allow for visualizing the grooves of the Forza implant for easier alignment.

To use the Articulating Tamp, verify that the gears are loose. If the gears are not loose, turn the center knob counter-clockwise to loosen the gears, then put the distal head of the Tamp into the position desired using your fingers. Firmly turn the center knob clockwise to tighten the gears and confirm that they are tightened. Align the rails of the Articulating Tamp with the grooves of the Forza PEEK, Ti, or PTC Curved Implant in situ and impact the metal strike plate to push the implant. Use fluoroscopy to verify the implant position.

To steer the implant additionally while in situ, loosen the distal gears by turning the center knob counter-clockwise. Then with the gears loosened, move the handle of the Articulating Tamp to the desired angle. Turn the center knob clockwise to tighten the gears firmly. Again confirm the implant position with fluoroscopy.

Repeat until the desired implant position is achieved and confirmed with fluoroscopy. Before removing the Articulating Tamp from the disc space, loosen the gears to avoid the possibility of damaging soft tissues.

Use A/P and lateral fluoroscopy for placement and trajectory. The tantalum fluoroscopy markers are 1mm from the anterior and posterior edge of the Forza PEEK and 1mm from the anterior edge of the Forza PTC implant.

Use supplemental fixation for intervertebral body fusion stability.

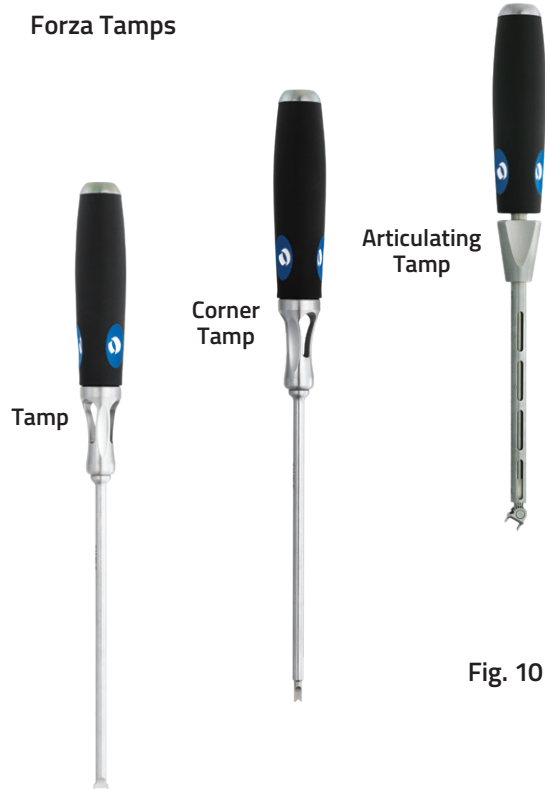

Fig. 10

Forza PEEK Radiographic Image

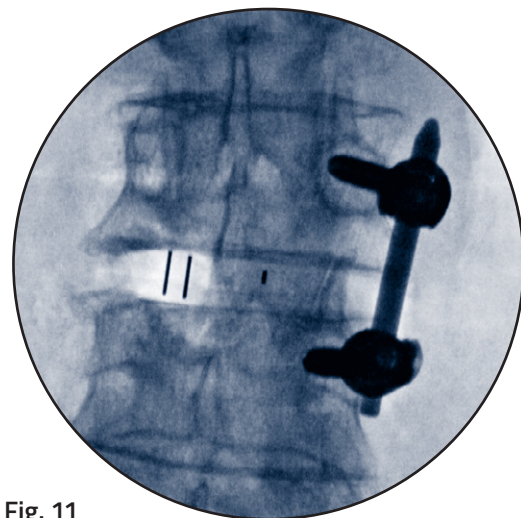

Fig. 11

6. IMPLANTS POSITIONING



Curved Implant
Axial View



Curved Implant
Lateral View



Curved Implant
Posterior View



Straight Implant - Oblique
Axial View



Straight Implant - Oblique
Lateral View



Straight Implant - Oblique
Posterior View



Straight Implant - Bilateral
Axial View



Straight Implant - Bilateral
Lateral View



Straight Implant - Bilateral
Posterior View

*This is a visual representation for Forza PEEK, Forza Ti, and Forza PTC.

7. FORZA IMPLANTS REMOVAL

Straight Implant Remover

Follow these steps for removing the Forza PEEK, PTC or Ti implant.

1. Use fluoroscopy to determine exact implant location.
2. Slide the fork of the Implant Remover into the implant grooves until the nubs engage with a click.
3. Turn the knob to lock the implant.
4. Attach the Slap Hammer by aligning it to the Implant Remover, pulling up the two prongs and sliding it down, then turning it clockwise to lock it. (**Fig. 12a**)
5. Pull up on the sleeve of the Slap Hammer to remove the implant. (**Fig. 12b**)
6. Remove the Slap Hammer by holding the tip of the Straight Implant Remover distally and pull the two prongs up, turning the Slap Hammer counter-clockwise to unlock it, and slide it off from the Straight Implant Remover.
7. To remove the implant, unlock the knob and cam the implant slightly while pulling it away from the Implant Remover.

Curved Implant and Forza Implant Removal

General surgical instruments can be used for curved implant removal.

NOTE: Forza implants may be capable of removal by threading corresponding inserter into the posterior opening of the implant.

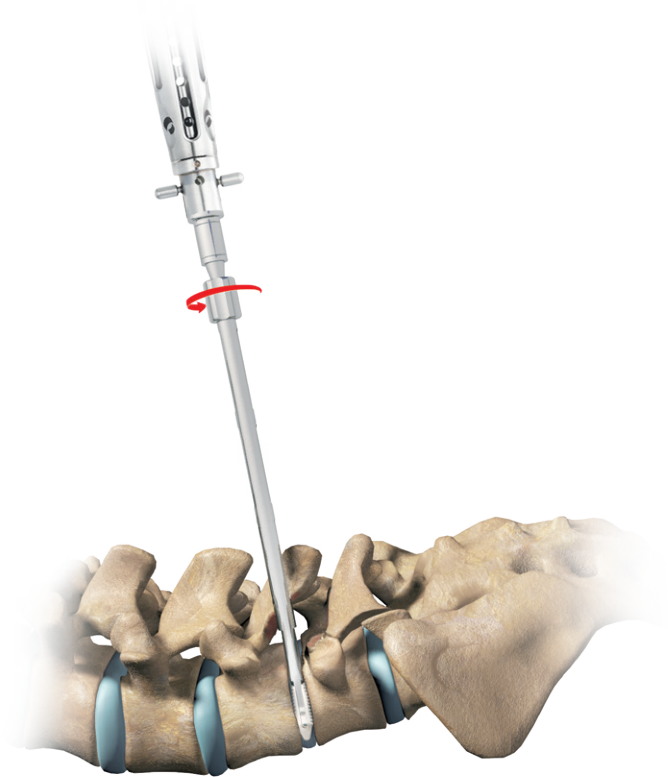

Fig. 12a

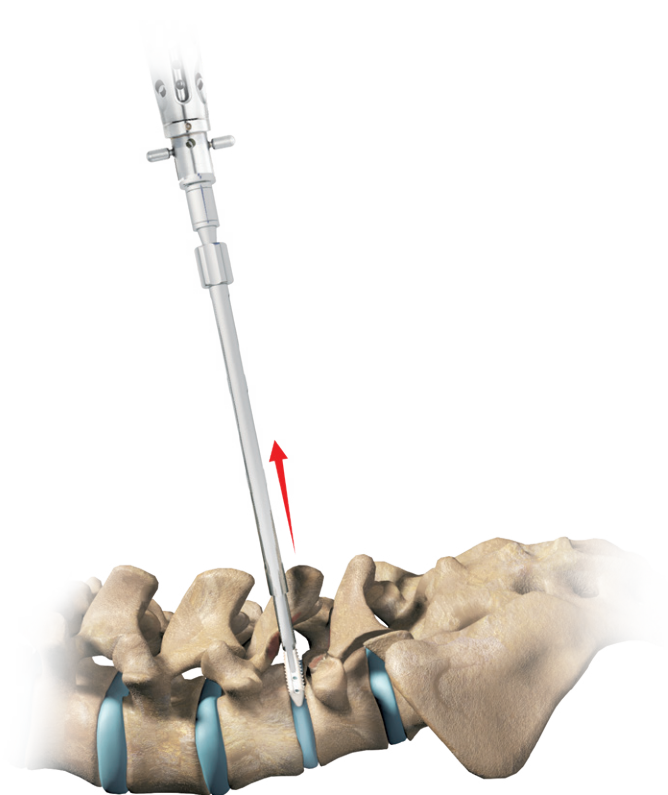
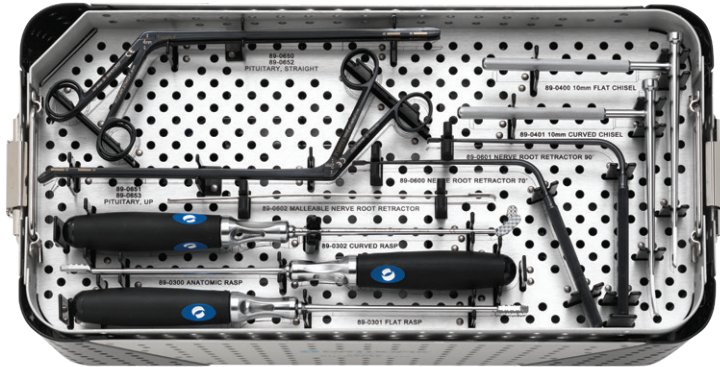

Fig. 12b

Instrument Cases

Discectomy Case Top Tray



Part #	Description	Qty
89-0092	Discectomy Case	1
20113133	Discectomy Case Lid	1
20113134	Discectomy Main Case	1
20113135	Discectomy Top Tray	1
20113136	Discectomy Mid Tray	1
20113137	Discectomy Bottom Tray	1

Discectomy Case Mid Tray

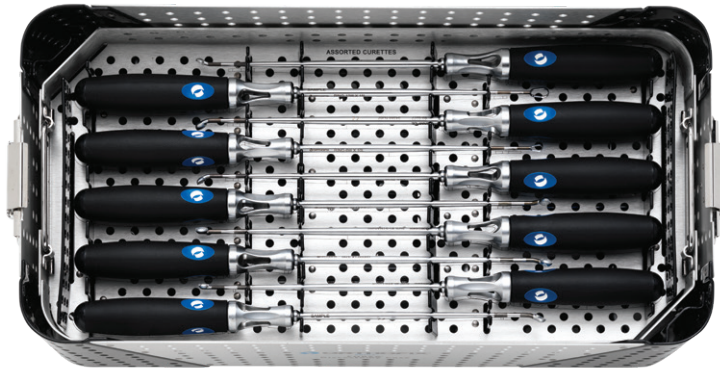

Discectomy Case Bottom Tray



Instrument Cases

Trial Case

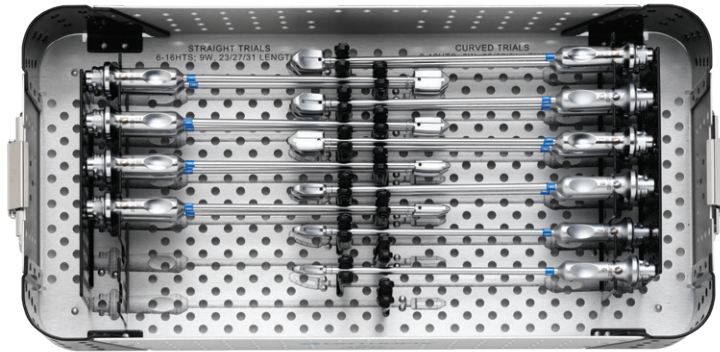

Part #	Description	Qty
89-0093	Trial Case	1
20113131	Trial Case Lid	1
20113132	Trial Main Case	1
Sets		
89-0021	Forza Instrument Set	
89-0031	Forza Discectomy Set	
89-0022	Forza Trial Set	

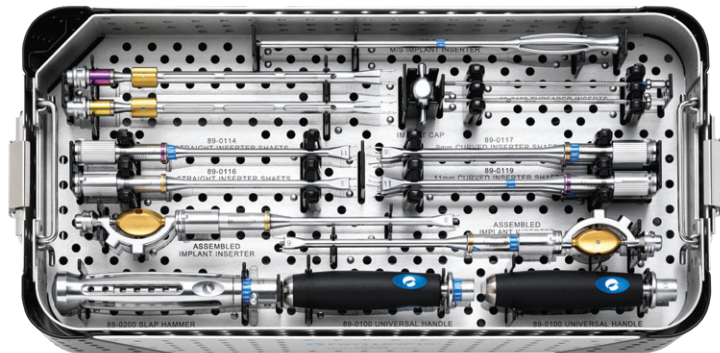

Instrument Case Top Tray



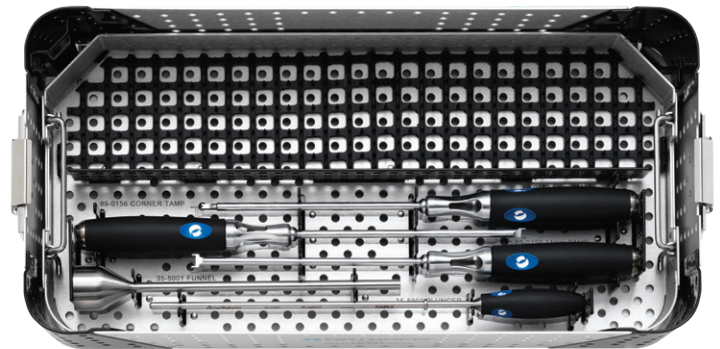

Part #	Description	Qty
Cases		
89-0094	Instrument Case	1
20113128	Instrument Case Lid	1
20113129	Instrument Main Case	1
20113130	Instrument Top Tray	1
20113138	Instrument Bottom Tray	1

Instrument Case Bottom Tray







	Part #	Description	Qty
	Paddle Distractors		
	89-0250	6mm Paddle Distractor	1
	89-0251	7mm Paddle Distractor	1
	89-0252	8mm Paddle Distractor	1
	89-0253	9mm Paddle Distractor	1
	89-0254	10mm Paddle Distractor	1
	89-0255	11mm Paddle Distractor	1
	89-0256	12mm Paddle Distractor	1
	89-0257	13mm Paddle Distractor	1
	89-0258	14mm Paddle Distractor	1
	89-0259	15mm Paddle Distractor	1
89-0260	16mm Paddle Distractor	1	
	Rasps		
	89-0300	Anatomic Rasp	1
	89-0301	Flat Rasp	1
89-0303	Curved Rasp	1	
	Curette		
	89-0372	#0 Curette Straight- Serrated	1
	89-0373	#1 Curette Straight - Serrated	1
	89-0376	#0 Curette Up - Serrated	1
	89-0377	#1 Curette Up - Serrated	1
	89-0380	#0 Curette Down - Serrated	1
	89-0381	#1 Curette Down - Serrated	1
	89-0385	#1 Curette Right - Serrated	1
	89-0389	#1 Curette Left - Serrated	1
	89-0390	Small Ring Curette - 6W x 10L	1
	89-0391	Large Ring Curette - 10W x 10L	1
	89-0342	#00 Curette 90° Down - Smooth	Order By Request
	89-0343	#0 Curette 90° Down - Smooth	Order By Request
	89-0344	#1 Curette 90° Down - Smooth	Order By Request
	89-0346	#00 Curette 90° Down - Serrated	Order By Request
	89-0347	#0 Curette 90° Down - Serrated	Order By Request
	89-0348	#1 Curette 90° Down - Serrated	Order By Request
	89-0351	#00 Curette Straight - Smooth	Order By Request
	89-0353	#1 Curette Straight - Smooth	Order By Request
	89-0355	#00 Curette Up - Smooth	Order By Request
	89-0356	#0 Curette Up - Smooth	Order By Request
	89-0357	#1 Curette Up - Smooth	Order By Request
	89-0359	#00 Curette Down - Smooth	Order By Request
	89-0360	#0 Curette Down - Smooth	Order By Request
	89-0361	#1 Curette Down - Smooth	Order By Request
	89-0363	#00 Curette Right - Smooth	Order By Request
	89-0364	#0 Curette Right - Smooth	Order By Request
	89-0365	#1 Curette Right - Smooth	Order By Request
	89-0368	#0 Curette Left - Smooth	Order By Request
	89-0369	#1 Curette Left - Smooth	Order By Request

	Part #	Description	Qty
	Chisels		
	89-0400	Flat Chisel	Order By Request
	89-0401	Curved Chisel	Order By Request





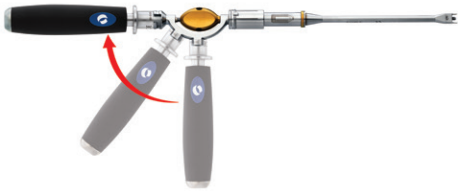

	Rotating Cutters		
	89-0406	6mm Rotating Cutter	1
	89-0407	7mm Rotating Cutter	1
	89-0408	8mm Rotating Cutter	1
	89-0409	9mm Rotating Cutter	1
	89-0410	10mm Rotating Cutter	1
	89-0411	11mm Rotating Cutter	1
	89-0412	12mm Rotating Cutter	1
	89-0413	13mm Rotating Cutter	1
	89-0414	14mm Rotating Cutter	1
	89-0415	15mm Rotating Cutter	1
	89-0416	16mm Rotating Cutter	1

	Trials	Order by Request	
	89-0206	9W x 27L x 6H, 0° Straight Trial	1
	89-0207	9W x 27L x 7H, 0° Straight Trial	1
	89-0208	9W x 27L x 8H, 0° Straight Trial	1
	89-0209	9W x 27L x 9H, 0° Straight Trial	1
	89-0210	9W x 27L x 10H, 0° Straight Trial	1
	89-0211	9W x 27L x 11H, 0° Straight Trial	1
	89-0212	9W x 27L x 12H, 0° Straight Trial	1
	89-0213	9W x 27L x 13H, 0° Straight Trial	1
	89-0214	9W x 27L x 14H, 0° Straight Trial	1
	89-0215	9W x 27L x 15H, 0° Straight Trial	1
	89-0216	9W x 27L x 16H, 0° Straight Trial	1
	89-0306	9W x 27L x 6H, 0° Curved Trial	1
	89-0307	9W x 27L x 7H, 0° Curved Trial	1
	89-0308	9W x 27L x 8H, 0° Curved Trial	1
	89-0309	9W x 27L x 9H, 0° Curved Trial	1
	89-0310	9W x 27L x 10H, 0° Curved Trial	1
	89-0311	9W x 27L x 11H, 0° Curved Trial	1
	89-0312	9W x 27L x 12H, 0° Curved Trial	1
	89-0313	9W x 27L x 13H, 0° Curved Trial	1
89-0314	9W x 27L x 14H, 0° Curved Trial	1	
89-0315	9W x 27L x 15H, 0° Curved Trial	1	
89-0316	9W x 27L x 16H, 0° Curved Trial	1	

Instruments Catalog

	Part #	Description	Qty
	Pituitary Rongeurs		
	89-0650	2mm Pituitary Rongeur - Straight Biting	1
	89-0651	2mm Pituitary Rongeur - Up Biting	1
	89-0652	4mm Pituitary Rongeur - Straight Biting	1
	89-0653	4mm Pituitary Rongeur - Up Biting	1
	Nerve Root Retractors		
	89-0600	Nerve Root Retractor, 70°	1
	89-0601	Nerve Root Retractor, 90°	1
	89-0602	Malleable Nerve Root Retractor	1
	Slap Hammer		
	89-0200	Slap Hammer	1
	Modular Implant Inserter		
	89-0100	Universal Implant Inserter Handle	2
	89-0113	Implant Inserter Body (C-Shaft) - (included within assembled Modular Implant Inserters)	2
	89-0114	9mm Straight Implant Shaft	2
	89-0116	11mm Straight Implant Shaft	2
	89-0117	9mm Curved Implant Shaft	2
	89-0119	11mm Curved Implant Shaft	2
	89-0120	Threaded Insert	6
	N/A	Assembled 9mm Straight Modular Inserter	1
	N/A	Assembled 9mm Curved Modular Inserter	1
89-0121	Impact Cap	1	
	MIS Inserter		
	89-0112	MIS Inserter	1

Instruments Catalog

	Part #	Description	Qty
	Order By Request Inserters		
	89-0509	9mm Monolithic Straight Implant Inserter	Order By Request
	89-0511	11mm Monolithic Straight Implant Inserter	Order By Request
	Tamps		
	89-0153	9mm Tamp	
	89-0155	11mm Tamp	
	89-0156	Corner (Y) Tamp	
	89-0609	9mm Articulating Tamp	Order By Request
	89-0611	11mm Articulating Tamp	Order By Request
	Funnel and Plunger		
	35-5001	Funnel	1
	35-5002	Plunger	1
	Straight Implant Remover		
	89-0108	9mm Straight Implant Remover	1
	89-0110	11mm Straight Implant Remover	1
	Other Order By Request Instruments		
	89-0500	Bone Packing Tool	Order By Request

Forza PEEK Straight Implants (0°)

Part #	Description	Graft Volume (cc)
9W x 23L, 0°		
89-1006SP	9W x 23L x 6H 0°	0.28
89-1007SP	9W x 23L x 7H 0°	0.32
89-1008SP	9W x 23L x 8H 0°	0.37
89-1009SP	9W x 23L x 9H 0°	0.43
89-1010SP	9W x 23L x 10H 0°	0.49
89-1011SP	9W x 23L x 11H 0°	0.54
89-1012SP	9W x 23L x 12H 0°	0.60
89-1013SP	9W x 23L x 13H 0°	0.66
89-1014SP	9W x 23L x 14H 0°	0.72
89-1015SP	9W x 23L x 15H 0°	0.77
89-1016SP	9W x 23L x 16H 0°	0.83
9W x 27L, 0°		
89-3006SP	9W x 27L x 6H 0°	0.37
89-3007SP	9W x 27L x 7H 0°	0.42
89-3008SP	9W x 27L x 8H 0°	0.46
89-3009SP	9W x 27L x 9H 0°	0.54
89-3010SP	9W x 27L x 10H 0°	0.61
89-3011SP	9W x 27L x 11H 0°	0.68
89-3012SP	9W x 27L x 12H 0°	0.75
89-3013SP	9W x 27L x 13H 0°	0.82
89-3014SP	9W x 27L x 14H 0°	0.89
89-3015SP	9W x 27L x 15H 0°	0.96
89-3016SP	9W x 27L x 16H 0°	1.03
11W x 23L, 0°		
89-2006SP	11W x 23L x 6H 0°	0.42
89-2007SP	11W x 23L x 7H 0°	0.48
89-2008SP	11W x 23L x 8H 0°	0.54
89-2009SP	11W x 23L x 9H 0°	0.62
89-2010SP	11W x 23L x 10H 0°	0.71
89-2011SP	11W x 23L x 11H 0°	0.79
89-2012SP	11W x 23L x 12H 0°	0.87
89-2013SP	11W x 23L x 13H 0°	0.95
89-2014SP	11W x 23L x 14H 0°	1.03
89-2015SP	11W x 23L x 15H 0°	1.11
89-2016SP	11W x 23L x 16H 0°	1.19

Part #	Description	Graft Volume (cc)
11W x 27L, 0°		
89-4006SP	11W x 27L x 6H 0°	0.55
89-4007SP	11W x 27L x 7H 0°	0.63
89-4008SP	11W x 27L x 8H 0°	0.70
89-4009SP	11W x 27L x 9H 0°	0.80
89-4010SP	11W x 27L x 10H 0°	0.91
89-4011SP	11W x 27L x 11H 0°	1.01
89-4012SP	11W x 27L x 12H 0°	1.11
89-4013SP	11W x 27L x 13H 0°	1.21
89-4014SP	11W x 27L x 14H 0°	1.32
89-4015SP	11W x 27L x 15H 0°	1.42
89-4016SP	11W x 27L x 16H 0°	1.52
11W x 31L, 0°		
89-6006SP	11W x 31L x 6H 0°	0.68
89-6007SP	11W x 31L x 7H 0°	0.78
89-6008SP	11W x 31L x 8H 0°	0.87
89-6009SP	11W x 31L x 9H 0°	1.00
89-6010SP	11W x 31L x 10H 0°	1.13
89-6011SP	11W x 31L x 11H 0°	1.26
89-6012SP	11W x 31L x 12H 0°	1.39
89-6013SP	11W x 31L x 13H 0°	1.51
89-6014SP	11W x 31L x 14H 0°	1.64
89-6015SP	11W x 31L x 15H 0°	1.77
89-6016SP	11W x 31L x 16H 0°	1.89
11W x 33L, 0°		
88-2006SP	11W x 33L x 6H 0°	0.74
88-2007SP	11W x 33L x 7H 0°	0.85
88-2008SP	11W x 33L x 8H 0°	0.94
88-2009SP	11W x 33L x 9H 0°	1.08
88-2010SP	11W x 33L x 10H 0°	1.22
88-2011SP	11W x 33L x 11H 0°	1.36
88-2012SP	11W x 33L x 12H 0°	1.50
88-2013SP	11W x 33L x 13H 0°	1.64
88-2014SP	11W x 33L x 14H 0°	1.77
88-2015SP	11W x 33L x 15H 0°	1.91
88-2016SP	11W x 33L x 16H 0°	2.05

Note: The 0° implants in the table above include 6-7mm heights with a parallel profile; and 8-14mm heights include an anatomic profile.



Forza Straight PEEK Implants (8°)

Part #	Description	Graft Volume (cc)	Anterior Height (mm)	Posterior Height (mm)
9W x 23L, 8°				
89-7008SP	9W x 23L x 8H, 8°	0.36	8.0	5.9
89-7009SP	9W x 23L x 9H, 8°	0.42	9.0	6.9
89-7010SP	9W x 23L x 10H, 8°	0.47	10.0	7.9
89-7011SP	9W x 23L x 11H, 8°	0.53	11.0	8.9
89-7012SP	9W x 23L x 12H, 8°	0.59	12.0	9.9
89-7013SP	9W x 23L x 13H, 8°	0.64	13.0	10.9
89-7014SP	9W x 23L x 14H, 8°	0.70	14.0	11.9
89-7015SP	9W x 23L x 15H, 8°	0.75	15.0	12.9
89-7016SP	9W x 23L x 16H, 8°	0.81	16.0	13.9
9W x 27L, 8°				
89-9009SP	9W x 27L x 9H, 8°	0.52	9.0	6.3
89-9010SP	9W x 27L x 10H, 8°	0.60	10.0	7.3
89-9011SP	9W x 27L x 11H, 8°	0.67	11.0	8.3
89-9012SP	9W x 27L x 12H, 8°	0.74	12.0	9.3
89-9013SP	9W x 27L x 13H, 8°	0.81	13.0	10.3
89-9014SP	9W x 27L x 14H, 8°	0.88	14.0	11.3
89-9015SP	9W x 27L x 15H, 8°	0.95	15.0	12.3
89-9016SP	9W x 27L x 16H, 8°	1.02	16.0	13.3
11W x 23L, 8°				
89-8008SP	11W x 23L x 8H, 8°	0.53	8.0	5.9
89-8009SP	11W x 23L x 9H, 8°	0.61	9.0	6.9
89-8010SP	11W x 23L x 10H, 8°	0.69	10.0	7.9
89-8011SP	11W x 23L x 11H, 8°	0.77	11.0	8.9
89-8012SP	11W x 23L x 12H, 8°	0.85	12.0	9.9
89-8013SP	11W x 23L x 13H, 8°	0.93	13.0	10.9
89-8014SP	11W x 23L x 14H, 8°	1.01	14.0	11.9
89-8015SP	11W x 23L x 15H, 8°	1.09	15.0	12.9
89-8016SP	11W x 23L x 16H, 8°	1.16	16.0	13.9
11W x 27L, 8°				
89-1209SP	11W x 27L x 9H, 8°	0.78	9.0	6.3
89-1210SP	11W x 27L x 10H, 8°	0.89	10.0	7.3
89-1211SP	11W x 27L x 11H, 8°	0.99	11.0	8.3
89-1212SP	11W x 27L x 12H, 8°	1.09	12.0	9.3
89-1213SP	11W x 27L x 13H, 8°	1.19	13.0	10.3
89-1214SP	11W x 27L x 14H, 8°	1.29	14.0	11.3
89-1215SP	11W x 27L x 15H, 8°	1.39	15.0	12.3
89-1216SP	11W x 27L x 16H, 8°	1.49	16.0	13.3
11W x 31L, 8°				
89-1409SP	11W x 31L x 9H, 8°	0.96	9.0	5.7
89-1410SP	11W x 31L x 10H, 8°	1.09	10.0	6.7
89-1411SP	11W x 31L x 11H, 8°	1.22	11.0	7.7
89-1412SP	11W x 31L x 12H, 8°	1.35	12.0	8.7
89-1413SP	11W x 31L x 13H, 8°	1.47	13.0	9.7
89-1414SP	11W x 31L x 14H, 8°	1.60	14.0	10.7
89-1415SP	11W x 31L x 15H, 8°	1.73	15.0	11.7
89-1416SP	11W x 31L x 16H, 8°	1.85	16.0	12.7

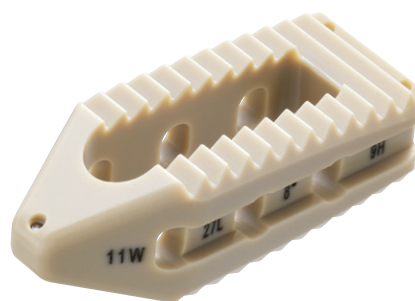

Forza PEEK Curved Implants (0°)

Part #	Description	Graft Volume (cc)
9W x 27L, 0°		
89-1706SP	9W x 27L x 6H, 0°	0.36
89-1707SP	9W x 27L x 7H, 0°	0.41
89-1708SP	9W x 27L x 8H, 0°	0.46
89-1709SP	9W x 27L x 9H, 0°	0.53
89-1710SP	9W x 27L x 10H, 0°	0.59
89-1711SP	9W x 27L x 11H, 0°	0.65
89-1712SP	9W x 27L x 12H, 0°	0.71
89-1713SP	9W x 27L x 13H, 0°	0.77
89-1714SP	9W x 27L x 14H, 0°	0.83
89-1715SP	9W x 27L x 15H, 0°	0.90
89-1716SP	9W x 27L x 16H, 0°	0.96
9W x 31L, 0°		
89-1906SP	9W x 31L x 6H, 0°	0.44
89-1907SP	9W x 31L x 7H, 0°	0.51
89-1908SP	9W x 31L x 8H, 0°	0.57
89-1909SP	9W x 31L x 9H, 0°	0.65
89-1910SP	9W x 31L x 10H, 0°	0.72
89-1911SP	9W x 31L x 11H, 0°	0.80
89-1912SP	9W x 31L x 12H, 0°	0.87
89-1913SP	9W x 31L x 13H, 0°	0.95
89-1914SP	9W x 31L x 14H, 0°	1.03
89-1915SP	9W x 31L x 15H, 0°	1.10
89-1916SP	9W x 31L x 16H, 0°	1.18
11W x 27L, 0°		
89-1806SP	11W x 27L x 6H, 0°	0.54
89-1807SP	11W x 27L x 7H, 0°	0.63
89-1808SP	11W x 27L x 8H, 0°	0.71
89-1809SP	11W x 27L x 9H, 0°	0.80
89-1810SP	11W x 27L x 10H, 0°	0.89
89-1811SP	11W x 27L x 11H, 0°	0.99
89-1812SP	11W x 27L x 12H, 0°	1.08
89-1813SP	11W x 27L x 13H, 0°	1.17
89-1814SP	11W x 27L x 14H, 0°	1.26
89-1815SP	11W x 27L x 15H, 0°	1.35
89-1816SP	11W x 27L x 16H, 0°	1.44
11W x 31L, 0°		
89-4206SP	11W x 31L x 6H, 0°	0.67
89-4207SP	11W x 31L x 7H, 0°	0.78
89-4208SP	11W x 31L x 8H, 0°	0.88
89-4209SP	11W x 31L x 9H, 0°	0.99
89-4210SP	11W x 31L x 10H, 0°	1.11
89-4211SP	11W x 31L x 11H, 0°	1.22
89-4212SP	11W x 31L x 12H, 0°	1.34
89-4213SP	11W x 31L x 13H, 0°	1.45
89-4214SP	11W x 31L x 14H, 0°	1.56
89-4215SP	11W x 31L x 15H, 0°	1.68
89-4216SP	11W x 31L x 16H, 0°	1.79



Note: The 0° implants in the table above include 6-7mm heights with a parallel profile; and 8-14mm heights include an anatomic profile.

Forza PEEK Curved Implants (8°)

Part #	Description	Graft Volume (cc)	Anterior Height (mm)	Posterior Height (mm)
9W x 27L, 8°				
89-4508SP	9W x 27L x 8H, 8°	0.43	8.0	6.8
89-4509SP	9W x 27L x 9H, 8°	0.49	9.0	7.8
89-4510SP	9W x 27L x 10H, 8°	0.56	10.0	8.8
89-4511SP	9W x 27L x 11H, 8°	0.62	11.0	9.8
89-4512SP	9W x 27L x 12H, 8°	0.68	12.0	10.8
89-4513SP	9W x 27L x 13H, 8°	0.74	13.0	11.8
89-4514SP	9W x 27L x 14H, 8°	0.80	14.0	12.8
89-4515SP	9W x 27L x 15H, 8°	0.86	15.0	13.8
89-4516SP	9W x 27L x 16H, 8°	0.92	16.0	14.8
9W x 31L, 8°				
89-4708SP	9W x 31L x 8H, 8°	0.53	8.0	6.8
89-4709SP	9W x 31L x 9H, 8°	0.61	9.0	7.8
89-4710SP	9W x 31L x 10H, 8°	0.68	10.0	8.8
89-4711SP	9W x 31L x 11H, 8°	0.76	11.0	9.8
89-4712SP	9W x 31L x 12H, 8°	0.83	12.0	10.8
89-4713SP	9W x 31L x 13H, 8°	0.91	13.0	11.8
89-4714SP	9W x 31L x 14H, 8°	0.99	14.0	12.8
89-4715SP	9W x 31L x 15H, 8°	1.06	15.0	13.8
89-4716SP	9W x 31L x 16H, 8°	1.14	16.0	14.8
11W x 27L, 8°				
89-4608SP	11W x 27L x 8H, 8°	0.64	8.0	6.5
89-4609SP	11W x 27L x 9H, 8°	0.74	9.0	7.5
89-4610SP	11W x 27L x 10H, 8°	0.83	10.0	8.5
89-4611SP	11W x 27L x 11H, 8°	0.92	11.0	9.5
89-4612SP	11W x 27L x 12H, 8°	1.01	12.0	10.5
89-4613SP	11W x 27L x 13H, 8°	1.11	13.0	11.5
89-4614SP	11W x 27L x 14H, 8°	1.20	14.0	12.5
89-4615SP	11W x 27L x 15H, 8°	1.29	15.0	13.5
89-4616SP	11W x 27L x 16H, 8°	1.38	16.0	14.5
11W x 31L, 8°				
89-4808SP	11W x 31L x 8H, 8°	0.80	8.0	6.5
89-4809SP	11W x 31L x 9H, 8°	0.91	9.0	7.5
89-4810SP	11W x 31L x 10H, 8°	1.03	10.0	8.5
89-4811SP	11W x 31L x 11H, 8°	1.14	11.0	9.5
89-4812SP	11W x 31L x 12H, 8°	1.26	12.0	10.5
89-4813SP	11W x 31L x 13H, 8°	1.37	13.0	11.5
89-4814SP	11W x 31L x 14H, 8°	1.49	14.0	12.5
89-4815SP	11W x 31L x 15H, 8°	1.60	15.0	13.5
89-4816SP	11W x 31L x 16H, 8°	1.71	16.0	14.5

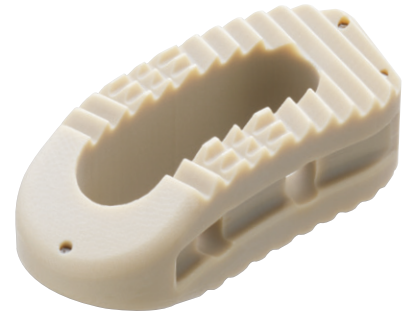

Forza PTC Straight Implants (0°)

Part #	Description	Graft Volume (cc)
9W X 23L, 0°		
38-1007SP	9W X 23L X 7H, 0°	0.28
38-1008SP	9W X 23L X 8H, 0°	0.32
38-1009SP	9W X 23L X 9H, 0°	0.36
38-1010SP	9W X 23L X 10H, 0°	0.40
38-1011SP	9W X 23L X 11H, 0°	0.44
38-1012SP	9W X 23L X 12H, 0°	0.48
38-1013SP	9W X 23L X 13H, 0°	0.52
38-1014SP	9W X 23L X 14H, 0°	0.56
9W X 27L, 0°		
38-3007SP	9W X 27L X 7H, 0°	0.37
38-3008SP	9W X 27L X 8H, 0°	0.42
38-3009SP	9W X 27L X 9H, 0°	0.46
38-3010SP	9W X 27L X 10H, 0°	0.51
38-3011SP	9W X 27L X 11H, 0°	0.56
38-3012SP	9W X 27L X 12H, 0°	0.61
38-3013SP	9W X 27L X 13H, 0°	0.66
38-3014SP	9W X 27L X 14H, 0°	0.71
11W X 27L, 0°		
38-4007SP	11W X 27L X 7H, 0°	0.58
38-4008SP	11W X 27L X 8H, 0°	0.66
38-4009SP	11W X 27L X 9H, 0°	0.71
38-4010SP	11W X 27L X 10H, 0°	0.79
38-4011SP	11W X 27L X 11H, 0°	0.87
38-4012SP	11W X 27L X 12H, 0°	0.95
38-4013SP	11W X 27L X 13H, 0°	1.03
38-4014SP	11W X 27L X 14H, 0°	1.11
11W X 31L, 0°		
38-6007SP	11W X 31L X 7H, 0°	0.72
38-6008SP	11W X 31L X 8H, 0°	0.81
38-6009SP	11W X 31L X 9H, 0°	0.90
38-6010SP	11W X 31L X 10H, 0°	1.00
38-6011SP	11W X 31L X 11H, 0°	1.09
38-6012SP	11W X 31L X 12H, 0°	1.19
38-6013SP	11W X 31L X 13H, 0°	1.29
38-6014SP	11W X 31L X 14H, 0°	1.39

Note: The 0° implants in the table above include 7mm heights with a parallel profile; and 8-14mm heights include an anatomic profile.

Forza PTC Straight Implants (8°)

Part #	Description	Graft Volume (cc)	Anterior Heights (mm)	Posterior Heights (mm)
9W X 23L, 8°				
38-7008SP	9W X 23L X 8H, 8°	0.33	8.3	6.0
38-7009SP	9W X 23L X 9H, 8°	0.36	9.2	6.5
38-7010SP	9W X 23L X 10H, 8°	0.40	10.2	7.5
38-7011SP	9W X 23L X 11H, 8°	0.44	11.2	8.5
38-7012SP	9W X 23L X 12H, 8°	0.48	12.2	9.5
38-7013SP	9W X 23L X 13H, 8°	0.52	13.2	10.5
38-7014SP	9W X 23L X 14H, 8°	0.56	14.2	11.5
9W X 27L, 8°				
38-9009SP	9W X 27L X 9H, 8°	0.46	9.1	5.9
38-9010SP	9W X 27L X 10H, 8°	0.51	10.1	6.9
38-9011SP	9W X 27L X 11H, 8°	0.56	11.1	7.9
38-9012SP	9W X 27L X 12H, 8°	0.61	12.1	8.9
38-9013SP	9W X 27L X 13H, 8°	0.66	13.1	9.9
38-9014SP	9W X 27L X 14H, 8°	0.71	14.1	10.9

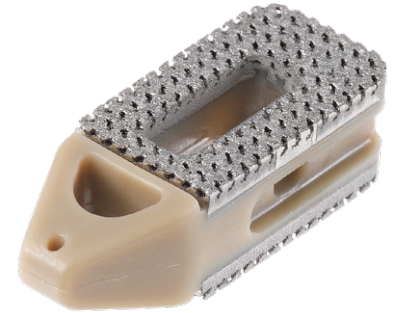

Forza PTC Curved Implants (0°)

Part #	Description	Graft Volume (cc)
9W X 27L, 0°		
38-1707SP	9W X 27L X 7H, 0°	0.36
38-1708SP	9W X 27L X 8H, 0°	0.41
38-1709SP	9W X 27L X 9H, 0°	0.44
38-1710SP	9W X 27L X 10H, 0°	0.50
38-1711SP	9W X 27L X 11H, 0°	0.55
38-1712SP	9W X 27L X 12H, 0°	0.60
38-1713SP	9W X 27L X 13H, 0°	0.65
38-1714SP	9W X 27L X 14H, 0°	0.69
11W X 27L, 0°		
38-1807SP	11W X 27L X 7H, 0°	0.54
38-1808SP	11W X 27L X 8H, 0°	0.61
38-1809SP	11W X 27L X 9H, 0°	0.66
38-1810SP	11W X 27L X 10H, 0°	0.73
38-1811SP	11W X 27L X 11H, 0°	0.81
38-1812SP	11W X 27L X 12H, 0°	0.88
38-1813SP	11W X 27L X 13H, 0°	0.95
38-1814SP	11W X 27L X 14H, 0°	1.03
11W X 31L, 0°		
38-4207SP	11W X 31L X 7H, 0°	0.69
38-4208SP	11W X 31L X 8H, 0°	0.78
38-4209SP	11W X 31L X 9H, 0°	0.84
38-4210SP	11W X 31L X 10H, 0°	0.93
38-4211SP	11W X 31L X 11H, 0°	1.02
38-4212SP	11W X 31L X 12H, 0°	1.13
38-4213SP	11W X 31L X 13H, 0°	1.22
38-4214SP	11W X 31L X 14H, 0°	1.31

Note: The 0° implants in the table above include 7mm heights with a parallel profile; and 8-14mm heights include an anatomic profile.

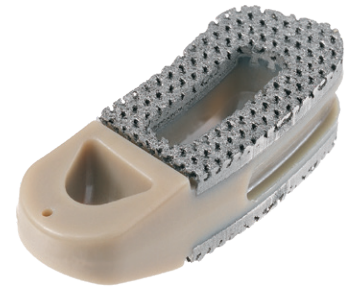

Forza PTC Curved Implants (8°)

Part #	Description	Graft Volume (cc)	Anterior Height (mm)	Posterior Height (mm)
9W X 27L, 8°				
38-4508SP	9W X 27L X 8H, 8°	0.38	8.3	7.1
38-4509SP	9W X 27L X 9H, 8°	0.42	9.0	7.7
38-4510SP	9W X 27L X 10H, 8°	0.46	10.0	8.7
38-4511SP	9W X 27L X 11H, 8°	0.51	11.0	9.7
38-4512SP	9W X 27L X 12H, 8°	0.56	12.0	10.7
38-4513SP	9W X 27L X 13H, 8°	0.61	13.0	11.7
38-4514SP	9W X 27L X 14H, 8°	0.66	14.0	12.7

Forza Ti Standard Straight Implant Kit (38-2001)

All implant footprints outside of the standard offering, listed below, are available upon request

Forza Ti Standard PLIF/TLIF Straight Implants

Part #	Description	Qty	Graft Volume (cc)
9W X 23L 0° PLIF			
38-2006SP	9W X 23L X 6H, 0°	3	0.33
38-2007SP	9W X 23L X 7H, 0°	3	0.38
38-2008SP	9W X 23L X 8H, 0°	3	0.42
38-2009SP	9W X 23L X 9H, 0°	3	0.48
38-2010SP	9W X 23L X 10H, 0°	3	0.54
9W X 23L 8° PLIF			
38-2508SP	9W X 23L X 8H, 8°	3	0.41
38-2509SP	9W X 23L X 9H, 8°	3	0.47
38-2510SP	9W X 23L X 10H, 8°	3	0.53
38-2511SP	9W X 23L X 11H, 8°	3	0.59
38-2512SP	9W X 23L X 12H, 8°	3	0.65
38-2513SP	9W X 23L X 13H, 8°	3	0.70
9W X 27L 8° TLIF			
38-2609SP	9W X 27L X 9H, 8°	2	0.58
38-2610SP	9W X 27L X 10H, 8°	2	0.66
38-2611SP	9W X 27L X 11H, 8°	2	0.73
38-2612SP	9W X 27L X 12H, 8°	2	0.81
38-2613SP	9W X 27L X 13H, 8°	2	0.88
38-2614SP	9W X 27L X 14H, 8°	2	0.96

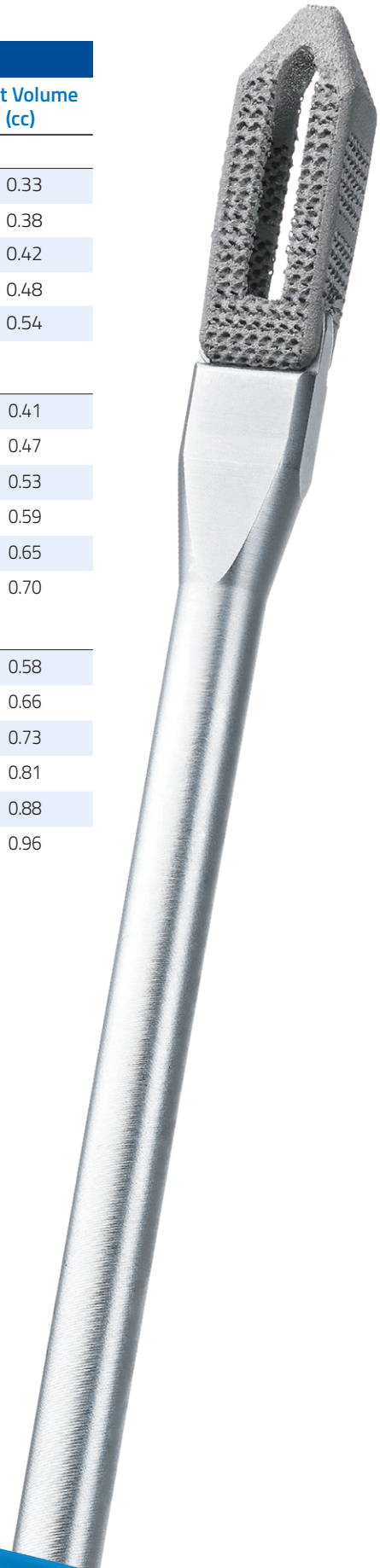

All Forza Ti Straight Implants (0°)

Part #	Description	Graft Volume (cc)
9W X 23L, 0°		
38-2006SP	9W X 23L X 6H, 0°	0.33
38-2007SP	9W X 23L X 7H, 0°	0.38
38-2008SP	9W X 23L X 8H, 0°	0.42
38-2009SP	9W X 23L X 9H, 0°	0.48
38-2010SP	9W X 23L X 10H, 0°	0.54
38-2011SP	9W X 23L X 11H, 0°	0.60
38-2012SP	9W X 23L X 12H, 0°	0.66
38-2013SP	9W X 23L X 13H, 0°	0.72
38-2014SP	9W X 23L X 14H, 0°	0.78
9W X 27L, 0°		
38-2106SP	9W X 27L X 6H, 0°	0.43
38-2107SP	9W X 27L X 7H, 0°	0.50
38-2108SP	9W X 27L X 8H, 0°	0.55
38-2109SP	9W X 27L X 9H, 0°	0.62
38-2110SP	9W X 27L X 10H, 0°	0.70
38-2111SP	9W X 27L X 11H, 0°	0.78
38-2112SP	9W X 27L X 12H, 0°	0.85
38-2113SP	9W X 27L X 13H, 0°	0.93
38-2114SP	9W X 27L X 14H, 0°	1.01
11W X 27L, 0°		
38-2206SP	11W X 27L X 6H, 0°	0.60
38-2207SP	11W X 27L X 7H, 0°	0.70
38-2208SP	11W X 27L X 8H, 0°	0.83
38-2209SP	11W X 27L X 9H, 0°	0.87
38-2210SP	11W X 27L X 10H, 0°	0.98
38-2211SP	11W X 27L X 11H, 0°	1.08
38-2212SP	11W X 27L X 12H, 0°	1.19
38-2213SP	11W X 27L X 13H, 0°	1.29
38-2214SP	11W X 27L X 14H, 0°	1.40
11W X 31L, 0°		
38-3206SP	11W X 31L X 6H, 0°	0.74
38-3207SP	11W X 31L X 7H, 0°	0.87
38-3208SP	11W X 31L X 8H, 0°	0.95
38-3209SP	11W X 31L X 9H, 0°	1.08
38-3210SP	11W X 31L X 10H, 0°	1.21
38-3211SP	11W X 31L X 11H, 0°	1.34
38-3212SP	11W X 31L X 12H, 0°	1.47
38-3213SP	11W X 31L X 13H, 0°	1.60
38-3214SP	11W X 31L X 14H, 0°	1.73

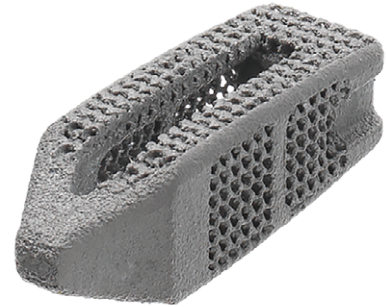

Note: The 0° implants in the table above include 6-7mm heights with a parallel profile; and 8-14mm heights include an anatomic profile.

All Forza Ti Straight Implants (8°)

Part #	Description	Graft Volume (cc)	Anterior Height (mm)	Posterior Height (mm)
9W X 23L, 8°				
38-2508SP	9W X 23L X 8H, 8°	0.41	8.0	5.9
38-2509SP	9W X 23L X 9H, 8°	0.47	9.0	6.9
38-2510SP	9W X 23L X 10H, 8°	0.53	10.0	7.9
38-2511SP	9W X 23L X 11H, 8°	0.59	11.0	8.9
38-2512SP	9W X 23L X 12H, 8°	0.65	12.0	9.9
38-2513SP	9W X 23L X 13H, 8°	0.70	13.0	10.9
38-2514SP	9W X 23L X 14H, 8°	0.76	14.0	11.9
9W X 27L, 8°				
38-2609SP	9W X 27L X 9H, 8°	0.58	9.0	6.3
38-2610SP	9W X 27L X 10H, 8°	0.66	10.0	7.3
38-2611SP	9W X 27L X 11H, 8°	0.73	11.0	8.3
38-2612SP	9W X 27L X 12H, 8°	0.81	12.0	9.3
38-2613SP	9W X 27L X 13H, 8°	0.88	13.0	10.3
38-2614SP	9W X 27L X 14H, 8°	0.96	14.0	11.3
11W X 27L, 8°				
38-2309SP	11W X 27L X 9H, 8°	0.84	9.0	6.3
38-2310SP	11W X 27L X 10H, 8°	0.94	10.0	7.3
38-2311SP	11W X 27L X 11H, 8°	1.05	11.0	8.3
38-2312SP	11W X 27L X 12H, 8°	1.15	12.0	9.3
38-2313SP	11W X 27L X 13H, 8°	1.25	13.0	10.3
38-2314SP	11W X 27L X 14H, 8°	1.36	14.0	11.3
11W X 31L, 8°				
38-3409SP	11W X 31L X 9H, 8°	1.01	9.0	5.7
38-3410SP	11W X 31L X 10H, 8°	1.14	10.0	6.7
38-3411SP	11W X 31L X 11H, 8°	1.27	11.0	7.7
38-3412SP	11W X 31L X 12H, 8°	1.40	12.0	8.7
38-3413SP	11W X 31L X 13H, 8°	1.53	13.0	9.7
38-3414SP	11W X 31L X 14H, 8°	1.66	14.0	10.7

Note: The 0° implants in the table above include 6-7mm heights with a parallel profile; and 8-14mm heights include an anatomic profile.

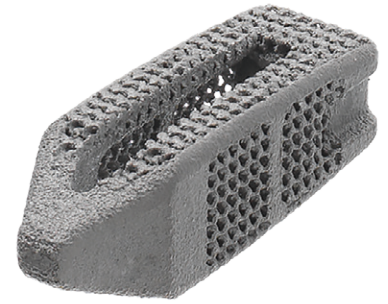

Forza Ti Standard Curved Implant Kit (38-2003)

All implant footprints outside of the standard offering, listed below, are available upon request

Forza Ti Standard Curved Implants

Part #	Description	Qty	Graft Volume (cc)
9W X 27L 0° TLIF			
38-2707SP	9W X 27L X 7H, 0°	2	0.47
38-2708SP	9W X 27L X 8H, 0°	2	0.53
38-2709SP	9W X 27L X 9H, 0°	2	0.60
38-2710SP	9W X 27L X 10H, 0°	2	0.67
38-2711SP	9W X 27L X 11H, 0°	2	0.74
38-2712SP	9W X 27L X 12H, 0°	2	0.82
9W X 27L 8° TLIF			
38-3608SP	9W X 27L X 8H, 8°	2	0.46
38-3609SP	9W X 27L X 9H, 8°	2	0.53
38-3610SP	9W X 27L X 10H, 8°	2	0.61
38-3611SP	9W X 27L X 11H, 8°	2	0.68
38-3612SP	9W X 27L X 12H, 8°	2	0.75
38-3613SP	9W X 27L X 13H, 8°	2	0.83
9W X 31L 8° TLIF			
38-3808SP	9W X 31L X 8H, 8°	2	0.60
38-3809SP	9W X 31L X 9H, 8°	2	0.69
38-3810SP	9W X 31L X 10H, 8°	2	0.78
38-3811SP	9W X 31L X 11H, 8°	2	0.88
38-3812SP	9W X 31L X 12H, 8°	2	0.97
38-3813SP	9W X 31L X 13 H, 8°	2	1.07

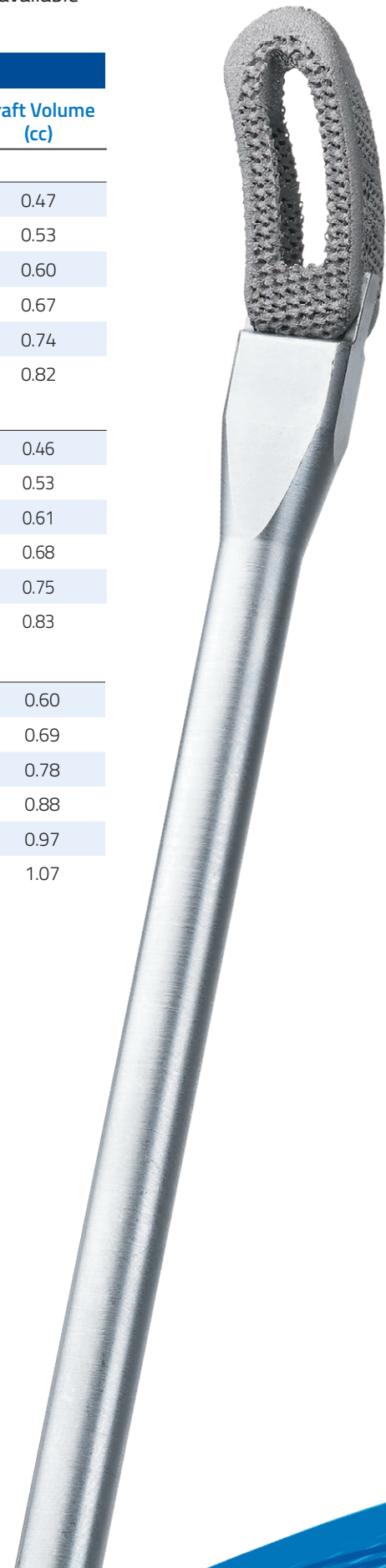

All Forza Ti Curved Implants (0°)

Part #	Description	Graft Volume (cc)
9W X 27L, 0°		
38-2706SP	9W X 27L X 6H, 0°	0.39
38-2707SP	9W X 27L X 7H, 0°	0.47
38-2708SP	9W X 27L X 8H, 0°	0.53
38-2709SP	9W X 27L X 9H, 0°	0.60
38-2710SP	9W X 27L X 10H, 0°	0.67
38-2711SP	9W X 27L X 11H, 0°	0.74
38-2712SP	9W X 27L X 12H, 0°	0.82
38-2713SP	9W X 27L X 13H, 0°	0.89
38-2714SP	9W X 27L X 14H, 0°	0.97
9W X 31L, 0°		
38-3706SP	9W X 31L X 6H, 0°	0.52
38-3707SP	9W X 31L X 7H, 0°	0.62
38-3708SP	9W X 31L X 8H, 0°	0.67
38-3709SP	9W X 31L X 9H, 0°	0.77
38-3710SP	9W X 31L X 10H, 0°	0.86
38-3711SP	9W X 31L X 11H, 0°	0.96
38-3712SP	9W X 31L X 12H, 0°	1.05
38-3713SP	9W X 31L X 13H, 0°	1.15
38-3714SP	9W X 31L X 14H, 0°	1.25
11W X 27L, 0°		
38-2806SP	11W X 27L X 6H, 0°	0.48
38-2807SP	11W X 27L X 7H, 0°	0.57
38-2808SP	11W X 27L X 8H, 0°	0.66
38-2809SP	11W X 27L X 9H, 0°	0.75
38-2810SP	11W X 27L X 10H, 0°	0.84
38-2811SP	11W X 27L X 11H, 0°	0.93
38-2812SP	11W X 27L X 12H, 0°	1.02
38-2813SP	11W X 27L X 13H, 0°	1.11
38-2814SP	11W X 27L X 14H, 0°	1.20
11W X 31L, 0°		
38-3506SP	11W X 31L X 6H, 0°	0.66
38-3507SP	11W X 31L X 7H, 0°	0.78
38-3508SP	11W X 31L X 8H, 0°	0.84
38-3509SP	11W X 31L X 9H, 0°	0.96
38-3510SP	11W X 31L X 10H, 0°	1.08
38-3511SP	11W X 31L X 11H, 0°	1.20
38-3512SP	11W X 31L X 12H, 0°	1.32
38-3513SP	11W X 31L X 13H, 0°	1.44
38-3514SP	11W X 31L X 14H, 0°	1.55



Note: The 0° implants in the table above include 6-7mm heights with a parallel profile; and 8-14mm heights include an anatomic profile.

All Forza Ti Curved Implants (8°)

Part #	Description	Graft Volume (cc)	Anterior Height (mm)	Posterior Height (mm)
9W X 27L, 8°				
38-3608SP	9W X 27L X 8H, 8°	0.46	8.0	6.8
38-3609SP	9W X 27L X 9H, 8°	0.53	9.0	7.8
38-3610SP	9W X 27L X 10H, 8°	0.61	10.0	8.8
38-3611SP	9W X 27L X 11H, 8°	0.68	11.0	9.8
38-3612SP	9W X 27L X 12H, 8°	0.75	12.0	10.8
38-3613SP	9W X 27L X 13H, 8°	0.83	13.0	11.8
38-3614SP	9W X 27L X 14H, 8°	0.90	14.0	12.8
9W X 31L, 8°				
38-3808SP	9W X 31L X 8H, 8°	0.60	8.0	6.8
38-3809SP	9W X 31L X 9H, 8°	0.69	9.0	7.8
38-3810SP	9W X 31L X 10H, 8°	0.78	10.0	8.8
38-3811SP	9W X 31L X 11H, 8°	0.88	11.0	9.8
38-3812SP	9W X 31L X 12H, 8°	0.97	12.0	10.8
38-3813SP	9W X 31L X 13H, 8°	1.07	13.0	11.8
38-3814SP	9W X 31L X 14H, 8°	1.16	14.0	12.8
11W X 31L, 8°				
38-3908SP	11W X 31L X 8H, 8°	0.78	8.0	6.5
38-3909SP	11W X 31L X 9H, 8°	0.90	9.0	7.5
38-3910SP	11W X 31L X 10H, 8°	1.01	10.0	8.5
38-3911SP	11W X 31L X 11H, 8°	1.13	11.0	9.5
38-3912SP	11W X 31L X 12H, 8°	1.25	12.0	10.5
38-3913SP	11W X 31L X 13H, 8°	1.37	13.0	11.5
38-3914SP	11W X 31L X 14H, 8°	1.49	14.0	12.5



MODULAR IMPLANT INSERTER: DISASSEMBLY AND ASSEMBLY

There are four (4) parts to the Modular Implant Inserter: 1) the Inserter Shaft, 2) the Instrument Body, 3) the Threaded Insert, and 4) the Universal Handle. (Fig. 1)

Disassemble the Modular Implant Inserter using the following steps.

1. Removal of the Universal Handle from the Modular Inserter

- a) Grip the instrument at the gold-colored knob and Inserter Shaft with one hand.
- b) Hold the top of Universal Handle with the other hand like a syringe plunger with your fingers on the sides of the metal top which is proximal to the gold-colored knob.
- c) Using two fingers to push down the metal top plunger like a syringe, turn the Universal Handle counter-clockwise until it separates from the Instrument Body (Fig. 2)

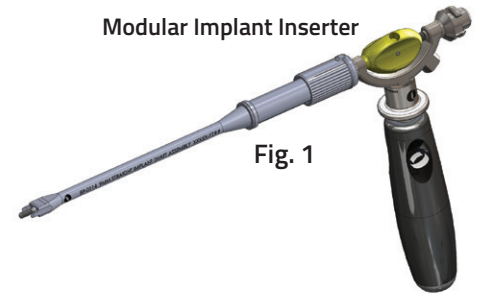

2. Disassembly of the Inserter Shaft from the Instrument Body

- a) Grip the Instrument Body at the gold-colored knob with the pronged tip of the instrument pointed away from you.
- b) Turn the ribbed collar on the Inserter Shaft, and firmly rotate it clockwise to disengage it from the Instrument Body. (Fig. 3)
- c) Continue rotating the ribbed collar with several rotations until it slides down and stops.
- d) Keep the ribbed collar distal from the Instrument Body and grip the Inserter Shaft with one hand and the Instrument Body with the other hand.
- e) Using caution to not drop the Threaded Insert out of the Inserter Shaft, firmly tug the Inserter Shaft apart from the Instrument Body. (Fig. 4)
- f) Slowly tilt the Inserter Shaft so that the prongs are higher than the ribbed collar to remove the Threaded Insert. (Fig. 5)
- g) If the Threaded Insert did not disengage from the Inserter Shaft with the tilt, gently tap the open port proximal to the ribbed sleeve on the palm of your hand to remove it.

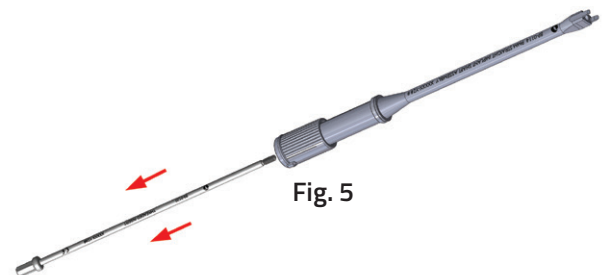
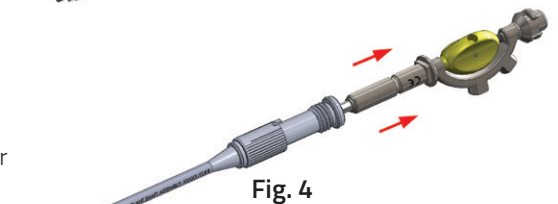
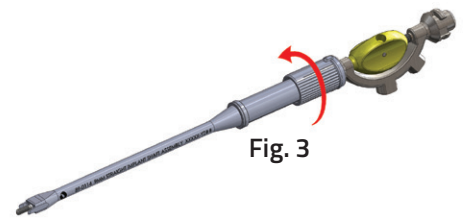

Assemble the Modular Implant Inserter using the following steps:

1. Hold the Inserter Shaft so that the prongs are pointed toward the floor, and carefully insert the Threaded Insert, threaded tip first, into the open hole proximal to the ribbed collar on the Inserter Shaft. **(Fig. 6)**
 - a) Confirm that the threaded tip of the Threaded Insert is showing outside of the Inserter Shaft opening.
2. With one hand gripping the Inserter Shaft and holding the ribbed collar distal to the opening, insert the Instrument Body with the gold-colored knob into the Inserter Shaft. **(Fig. 7)**
3. Turn the Inserter Shaft until the square connection snaps together with the Instrument Body and is fully seated.
 - a) Confirm that there is no gap between the Instrument Body and the Inserter Shaft.
4. With the Inserter Shaft prongs pointing away from you, rotate the ribbed collar counter-clockwise through several revolutions until the ribbed collar clicks and no gap remains between the ribbed collar on the Inserter Shaft and the Instrument Body. **(Fig. 8)**
 - a) Confirm that the ribbed collar is firmly engaged with the click and inspect that there is no gap between the ribbed collar and Instrument Body.
5. Assemble the Universal Handle to the Instrument Body.
 - a) Hold the metal top plunger like a syringe with your fingers on the sides. **(Fig. 9)**
 - b) While pulling down on the metal top plunger like a syringe, attach the Universal Handle to the Instrument Body and turn it until it is firmly attached.

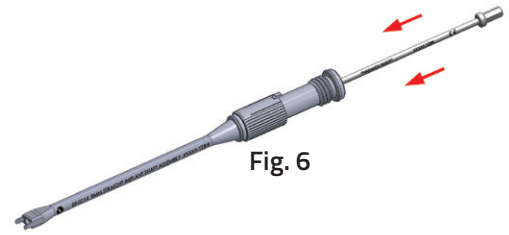

Fig. 6

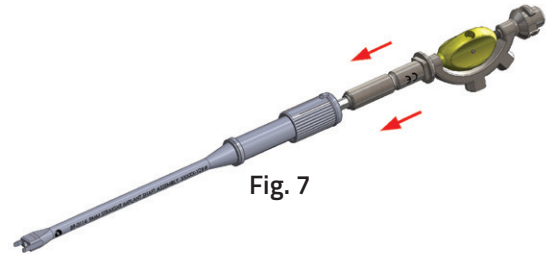

Fig. 7

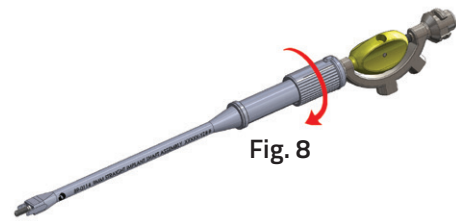

Fig. 8

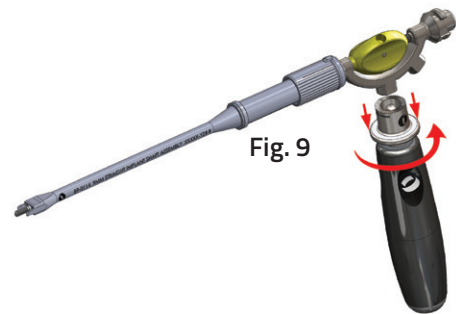

Fig. 9

Please visit [Orthofix.com/IFU](https://www.orthofix.com/IFU) for full information on indications for use, contraindications, warnings, precautions, adverse reactions information and sterilization.

Caution: Federal law (USA) restricts this device to sale by or on the order of a physician. Proper surgical procedure is the responsibility of the medical professional. Operative techniques are furnished as an informative guideline. Each surgeon must evaluate the appropriateness of a technique based on his or her personal medical credentials and experience.

 Orthofix
3451 Plano Parkway
Lewisville, Texas 75056-9453 USA
1.214.937.3199
1.888.298.5700
www.orthofix.com

EC REP Medical Device Safety Services (MDSS):
Schiffgraben 41
30175, Hannover
Germany
www.mdss.com

Rx Only
 2797

Orthofix products or services referenced herein are trademarks or registered trademarks of Orthofix Medical Inc. and its group of companies. All rights reserved.

Orthofix.com

OP-38-9901-US Rev AE
FO-2201 © Orthofix US LLC. 3/2022

 **ORTHOFIX**[®]
SPINE