

Mecta-C PLATE

ANTERIOR CERVICAL PLATE SYSTEM

UNIQUE PATIENTS SPECIFIC INDICATIONS IN ONE SYSTEM

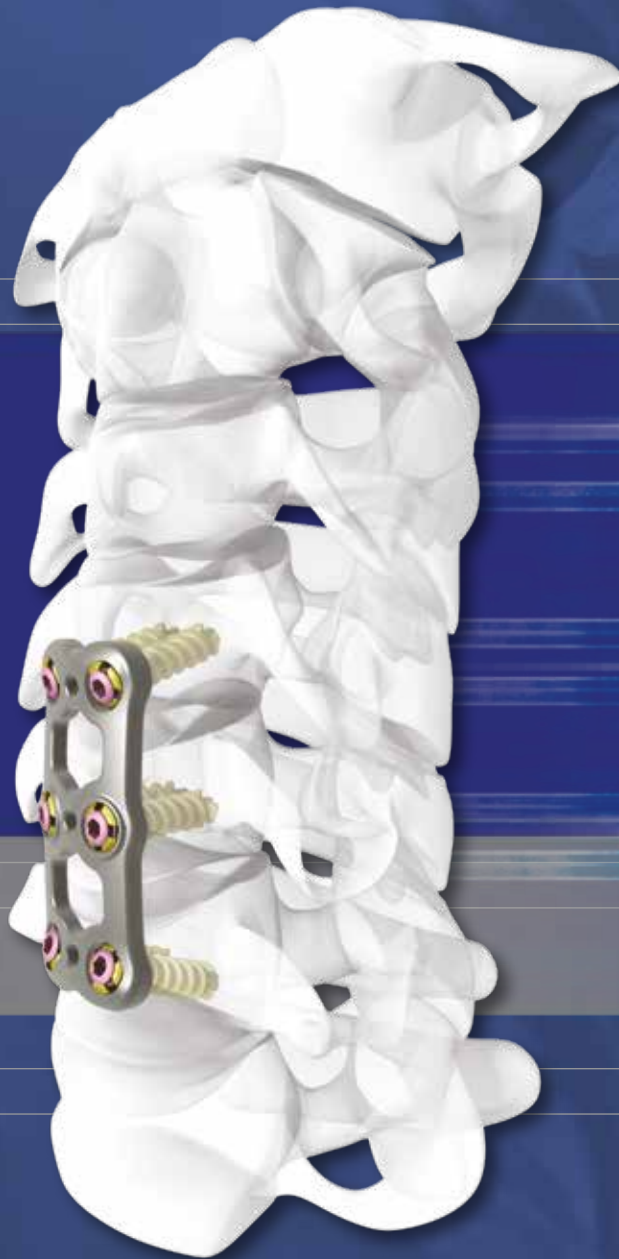

Surgical Technique

Joint

Spine

Sports Med

INDEX

| | |
|--|-----------|
| 1. INTRODUCTION | 4 |
| 1.1 Mecta-C Cervical Plates | 4 |
| 1.2 Bone Screws | 4 |
| 1.3 Indications | 6 |
| 1.4 Contraindications | 6 |
| 1.5 Pre-Operative Planning | 6 |
| 2. PATIENT POSITIONING SPINE EXPOSURE | 6 |
| 3. IMPLANT SELECTION | 7 |
| 3.1 Handling Options & Drill Guides | 7 |
| 3.2 Trial Insertion | 9 |
| 4. IMPLANT PLATE PREPARATION AND POSITIONING | 10 |
| 4.1 Implant Selection | 10 |
| 4.2 Bone Preparation | 10 |
| 4.3 Plate Positioning with the Self-Drilling/Self-Tapping Screws | 11 |
| 4.4 Screw Locking | 12 |
| 4.5 Screw Removal | 12 |
| 5. MODULAR RIGID SCREWDRIVER | 14 |
| 5.1 Bone screw preparation | 14 |
| 5.2 Modular rigid screw driver preparation | 15 |
| 5.3 Screw Insertion | 16 |
| 5.4 Screw Locking | 17 |
| 6. IMPLANTS NOMENCLATURE | 18 |
| 6.1 Sterile Package | 18 |

1. INTRODUCTION

The Mecta-C Anterior Cervical Plate System is designed to offer maximum biomechanical stability in situ and high flexibility in term of implants range selection and configurations.

The Mecta-C Anterior Cervical Plate System devices are made of Titanium alloy (Ti-6Al-4V). The plates are prelordosed to match the natural curvature of the spine and are designed to cover up to four level configurations ranging from 20mm - 92mm in length. Also, constrained, semi-constrained or hybrid angle constructs may be built using Fixed or Variable angle bone screws system; provided with Self-Tapping and Self-Drilling options the bone screws are available in two diameters and several lengths.

Overall, the different Mecta-C plates configurations bring beneficial advantages to meet different patients' needs in tumor, trauma and degenerative as well as in deformity cases.

1.1 MECTA-C CERVICAL PLATES

The Cervical Plates are provided in the following configurations (fig.1):

- 1, 2, 3 and 4-Level
- Sizes ranging from 20 - 92mm in length (end-to-end plate measure).

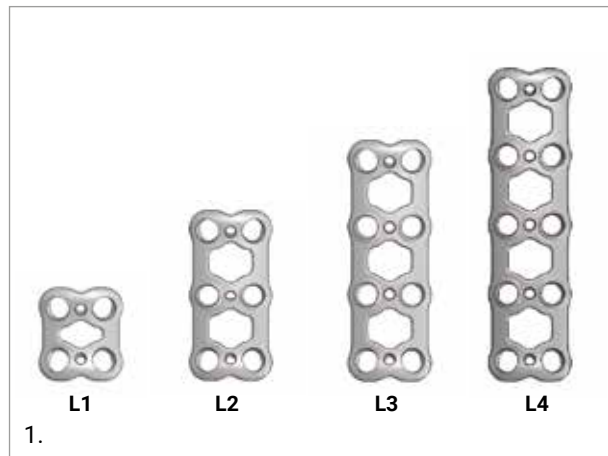

1.2 BONE SCREWS

The cervical bone screws are available in the following configurations:

- Primary screws: 4.0mm diameter 12mm 22mm length (1mm increment)
- Rescue screws: 4.5mm diameter 12mm 22mm length (2mm increment)

All the screws are polyaxial with the capability to convert into two configurations:

- Fixed screw [no micro movements allowed]
- Variable screw [micro movements allowed]

The screw configurations can be identified by their unique color-code:

Fixed screws (fig.2):

- 4.0 mm Self Tapping (Gold & Silver)
- 4.0 mm Self Drilling (Blue & Silver)
- 4.5mm Self Tapping (Green & Silver)



The fixed screw design is identified by the partial anodization (dual color) of the screw shank.

NOTICE: For the fixed screw design the color of the Locking screw can be either violet or silver.

Variable screws (fig.3):

- 4.0 mm Self Tapping (Full Gold)
- 4.0 mm Self Drilling (Full Blue)
- 4.5mm Self Tapping (Full Green)

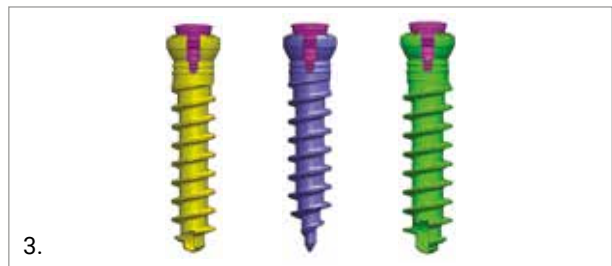

Self-Tapping and Self-Drilling screws are identified with the following tip design (fig.4):

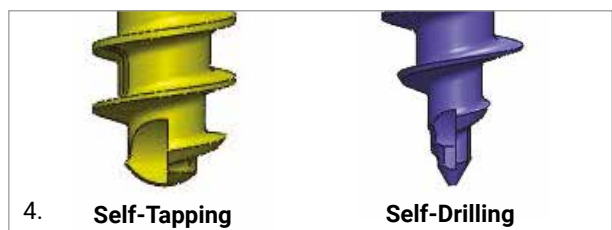

Construct design

The Mecta-C Plate head screw design incorporates the function of an expansion head screw matched with an inner pre-assembled locking screw. The specific design of the pre-assembled locking screw determines the degree of interaction versus the flanges of the bone screw head defining its fixed or variable configuration.

Constrained configuration - When the fixed screw is finally secured in place the locking screw expands against the flanges of the screw-head by locking the system within the hole plate.

The combination of the Mecta-C plate with the fixed screws provide a construct with superior stability, which properties may be beneficial in tumor, trauma and degenerative applications.

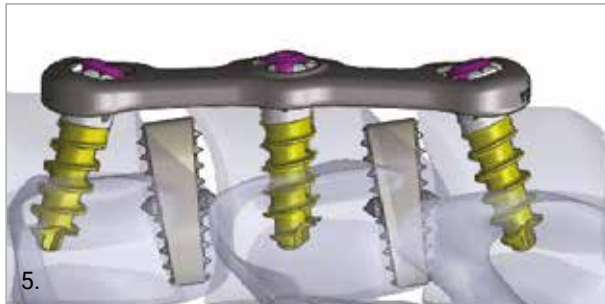

Semi constrained configuration - When the variable screw is finally secured in place the Locking screw partially expands against the flanges of the screw-head by allowing slight toggling of the screw within the hole plate.

A Variable construct allows optimal load sharing of the treated segments in degenerative cases, and may be especially beneficial in multi-level applications when major dynamic stabilization is requested.

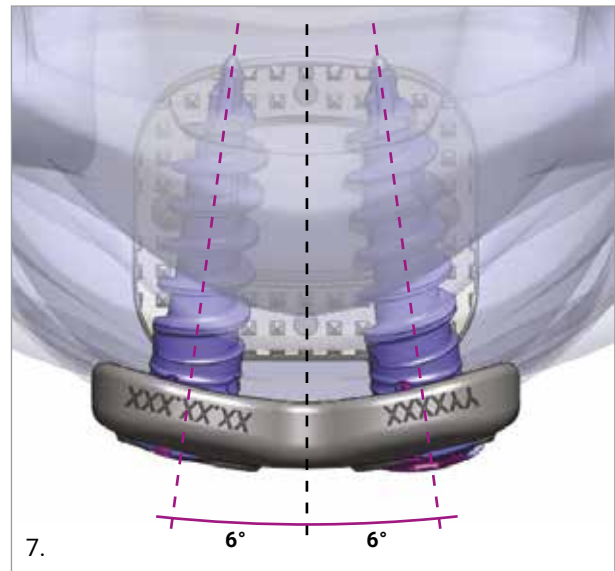
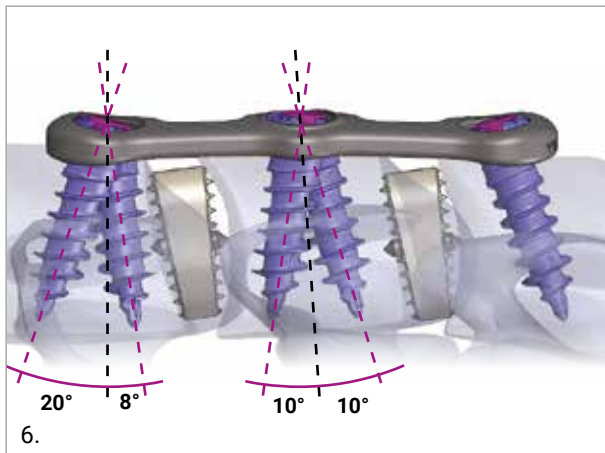

Hybrid configuration - The hybrid construct configuration can be obtained by using a combination of fixed and variable screws within the end holes of the plate.

The use of this type of construct allows to reach a stable configuration capable of providing proper load sharing at the graft receptor side.

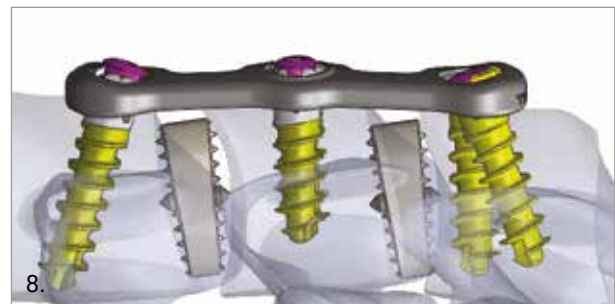

In all the construct configurations above cited the bone screws can be positioned with the following trajectories:

- Cranial/Caudal screws: 20° distal/-8° proximal and 6° medial convergent/6° lateral divergent angle, approximately.
- Mid screws: ±10° distal/proximal and 6° medial convergent/6° lateral divergent angle, approximately.

WARNING

In case of implantation of screws longer than 18mm, the screw length has to be verified by fluoroscopy prior to screw insertion; this is meant to prevent screw interference.

1.3 INDICATIONS

This system is intended for anterior interbody screw/plate fixation from C2 to T1. The system is indicated for use in the temporary stabilization of the anterior spine during the development of cervical spinal fusions in patients with: 1) degenerative disc disease (as defined by neck pain of discogenic origin with degeneration of the disc confirmed by patient history and radiographic studies), 2) trauma (including fractures), 3) tumors, 4) deformity (defined as kyphosis, lordosis, or scoliosis), 5) pseudarthrosis, and/or 6) failed previous fusions. This device system is intended for anterior cervical intervertebral body fusions only.

1.4 CONTRAINDICATIONS

This device is not approved for screw attachment to the posterior elements (pedicles) of the cervical, thoracic, or lumbar spine

Contraindications include, but are not limited to:

1. Infection, local to the operative site.
2. Signs of local inflammation.
3. Fever or leukocytosis.
4. Morbid obesity.
5. Pregnancy.
6. Mental illness.
7. Any medical or surgical condition which would preclude the potential benefit of spinal implant surgery, such as the elevation of sedimentation rate unexplained by other

diseases, elevation of white blood count (WBC), or a marked left shift in the WBC differential count.

8. Rapid joint disease, bone absorption, osteopenia, and/or osteoporosis. Osteoporosis is a relative contraindication since this condition may limit the degree of obtainable correction, the amount of mechanical fixation, and/or the quality of the bone graft.
9. Suspected or documented metal allergy or intolerance.
10. Any case not needing a bone graft and fusion or where fracture healing is not required.
11. Any case requiring the mixing of metals from different components.
12. Any patient having inadequate tissue coverage over the operative site or where there is inadequate bone stock, bone quality, or anatomical definition.
13. Any case not described in the Indications.
14. Any patient unwilling to cooperate with the post-operative instructions.
15. Any time implant utilization would interfere with anatomical structures or expected physiological performance.

1.5 PRE-OPERATIVE PLANNING

The review of MRI and/or CT based imaging to template and determine the type/size of the implants in order to match the patient's anatomy is a critical step in the pre-operative planning before each surgery.

2. PATIENT POSITIONING SPINE EXPOSURE

The patient is placed in the supine position with the head slightly extended and resting on an appropriate base. A shoulder bump may be needed to generate the desired amount of cervical lordosis. The arms are secured along the sides of the body. The image intensifier is positioned in such a way to enable adequate intra-operative anteroposterior and lateral imaging.



A transverse incision is made along Langer's lines extending approximately from the sternocleidomastoid muscle to the midline. Correct location of the skin incision is accomplished either by using anatomic landmarks or by using image intensifier.

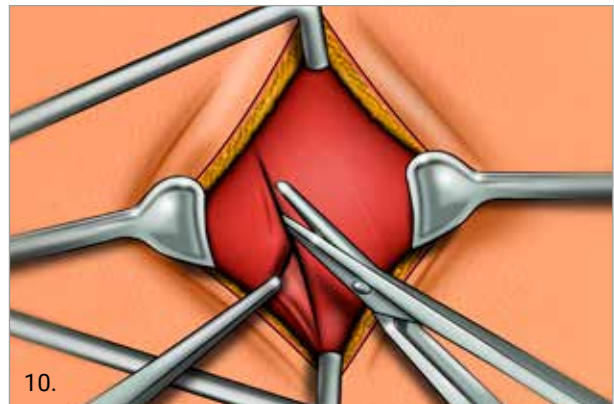

The platysmal layer is then incised either horizontally in line with the incision (shown) or vertically at the discretion of the surgeon.

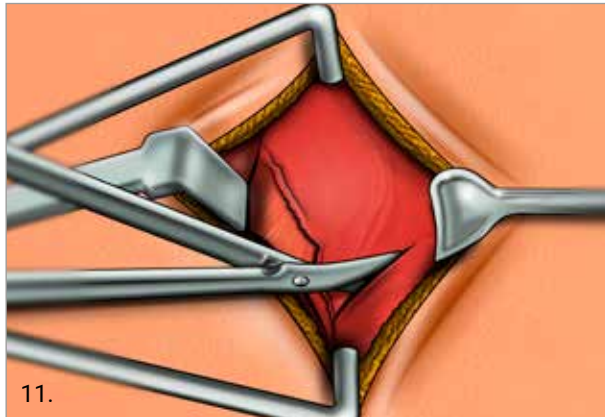

Incise the pretracheal fascia which allows for retraction of the midline structures. Perform blunt dissection using the index finger to expose the anterior cervical spine.

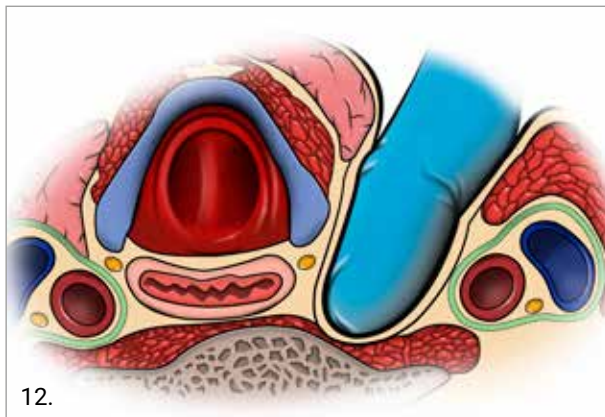

Electrocautery is used to elevate the longus colli muscles. Medio-lateral retractors are placed underneath the longus muscles in order to protect the sympathetic chain. Mark the appropriate disc and perform a lateral X-ray to verify the appropriate level.

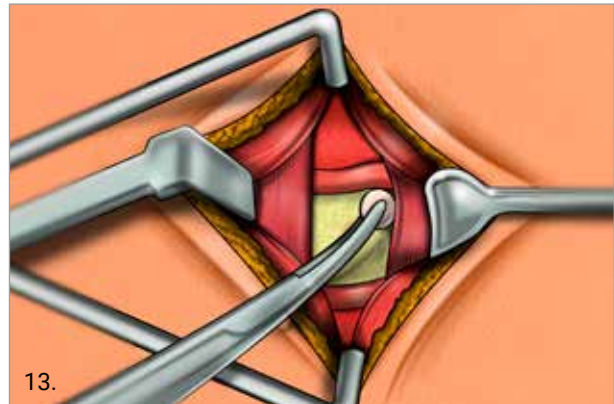

Then a Cranial/Caudal retractor can be placed to further optimize the visualization. The Mecta-C cervical Anterior Retractor/Distractor System can be used to provide optimal retraction/distraction maneuvers.

OPTION

After the cervical spine has been exposed and prepared perform the next steps (disc removal/decompression/cage insertion/corpectomy etc.) following the usual fashion in order to accommodate individual surgery needs. In case of disc replacement with cage(s) insertion the Mecta-C anterior cervical device can be combined with the Mecta-C plate system.

3. IMPLANT SELECTION

3.1 HANDLING OPTIONS & DRILL GUIDES

To handle the Mecta-C Plate Trials as well as the Implants, different options are available, thus providing the maximum flexibility during the selection/plates and screws placement process.

Cervical Plate Forceps

The Cervical Plate Forceps can be utilized to hold the plate from the medial/lateral sides.

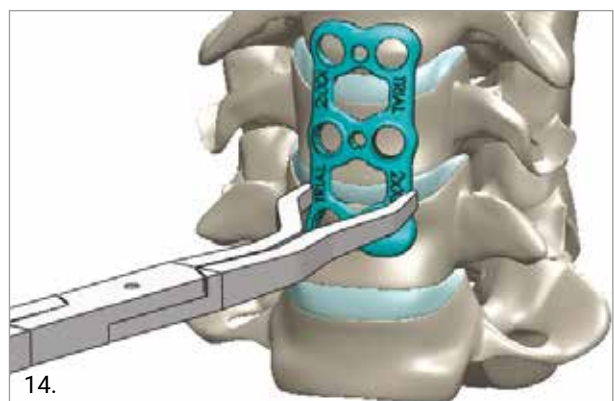
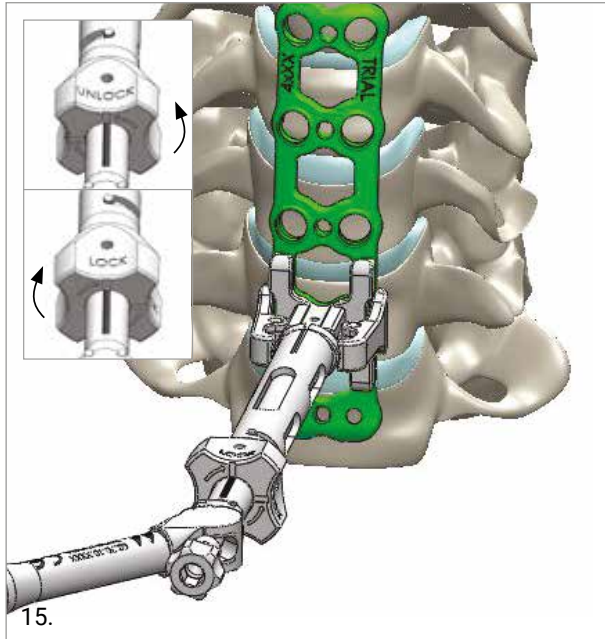

Plate Holder

The Plate Holder can be primarily utilized to provide superior stability to position the longer plates. To attach the implant to the Inserter, turn the thumb wheel to the “unlock” position and attach the implant. Turn the thumb wheel 90° into the “lock” position to firmly hold the Plate.



Handle Of The Plate Holder

The handle of the plate holder can be fixed at different angle positions: 45°; 60°; 90° on both Sagittal and Transverse plane.

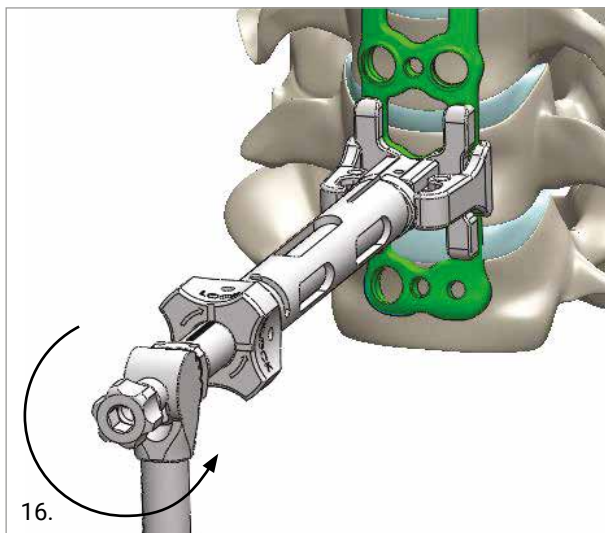

As alternative, the Single-hole as well as the Double-Hole Drilling Guide and the Universal Plate holder can be used to position the cervical plate in situ. The distal tip into the

medial/lateral hole(s) supporting the construct during the placement and the drilling steps.

These guides are considered fully locked when the tip is flush with the plate. When using the Universal Plate Holder the guide is securely locked into the plate by applying light downward pressure on the handle.

Single Hole and Double Hole Drilling Guide

Insert the distal tip into the medial/lateral hole(s) to support the plate during the placement and the drilling steps. These guides are considered engaged when the tip is flush with the plate.

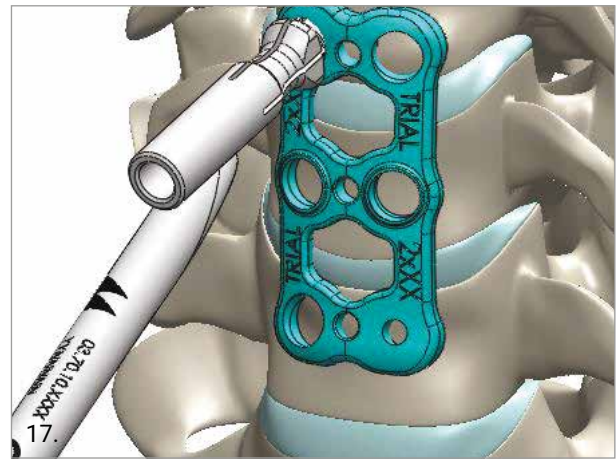

Universal Plate Holder

When using the Universal Plate Holder the guide is securely locked into the plate by pulling back the handle after the insertion of the tip into the plate hole.

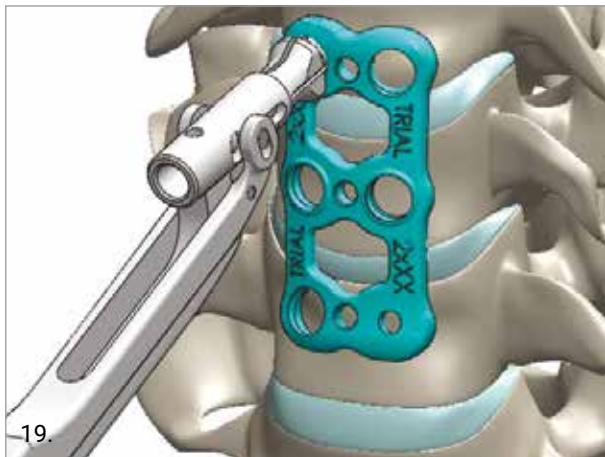

19.

NOTICE: if the guide cannot be released from the plate apply a slight pulling pressure on the trigger handle.

Fork Drilling Guide

In case of combination with the Mecta-C cervical cage implant(s) the Fork Drilling Guide can be used in order to provide self-centering during the drilling procedure. The Fork Drilling Guide perfectly fit with the several Mecta-C cervical implants providing a dedicated tool for the cervical cage/plate devices implantation.

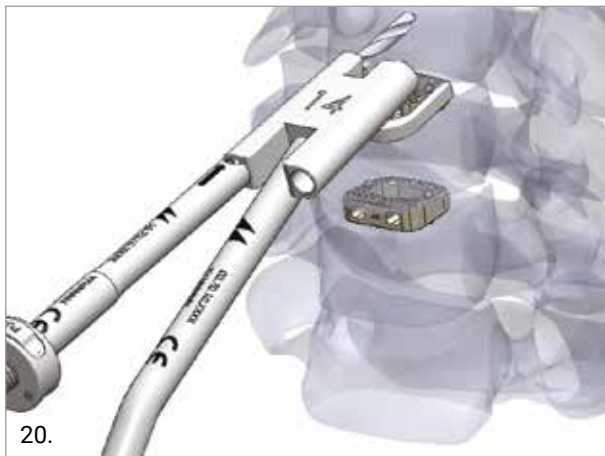

20.

3.2 TRIAL INSERTION

Select a Trial Plate of the estimated length and place it on the vertebral body to determine the actual plate length.

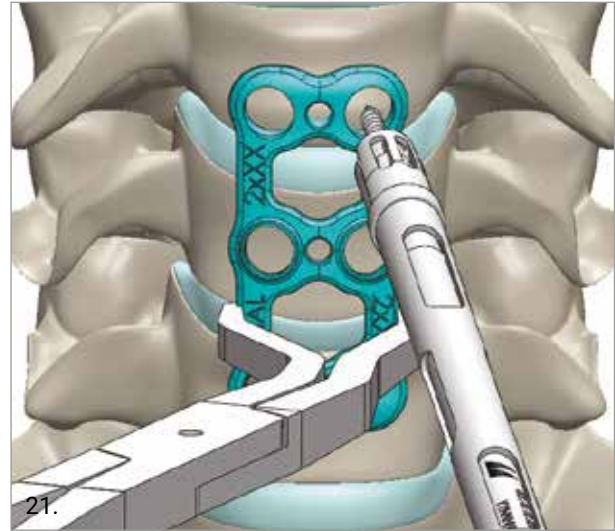

21.

If desired, hold the Trial Cervical Plate in place with the Temporary Fixation Pin. Using the Self-Retaining Screwdriver the pin can be inserted either in the central or in the medial/lateral holes to support the trial selection; in this latter case multiple sampling can be performed without remove the pin from the vertebral body.

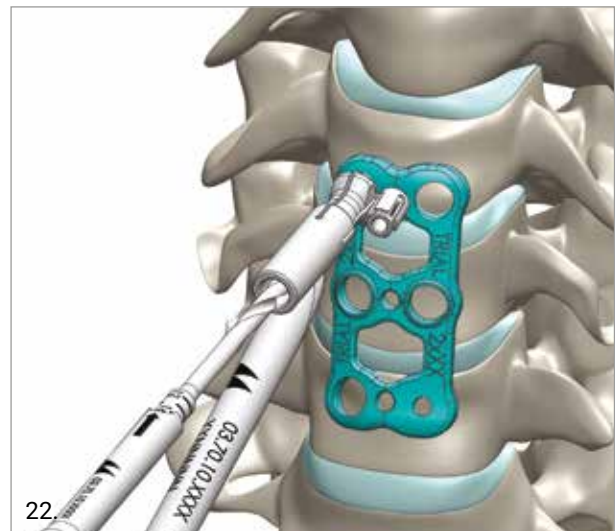

22.

CAUTION

Remove the Temporary Fixation Pin after the Trial selection is completed.

4. IMPLANT PLATE PREPARATION AND POSITIONING

4.1 IMPLANT SELECTION

After the plate length has been determined with the Trial selection, choose the appropriate Mecta-C cervical Plate and ensure that the plate's lordosis fits with the patient's anatomy.

NOTICE: the Mecta-C cervical plate is already provided with a lordotic curve; if required, a Cervical Plate Bender can be used to contour the plate in order to increase or decrease the lordotic curvature.

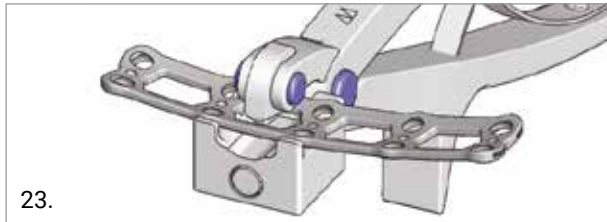

WARNING

Contour the cervical Plate only when needed. In contouring the cervical plate apply gradual bending steps and avoid excessive changes of the plate's curvature.

4.2 BONE PREPARATION

Place the selected Mecta-C cervical plate in the desired position onto the vertebral body and if desired, hold it in place with the Temporary Fixation Pin systems previously described.

Insert the Self-centering Awl into the plate hole to perforate the outer cortex; the depth of perforation can be controlled with the scale located on the Self-centering Awl shaft.



NOTICE: the length of the awl perforation is limited to 12mm as the inferior screw length size.

OPTION

Alternatively, seat one of the available drilling guides into plate hole and insert the Drill-bit with the desired length to determine the depth of perforation.

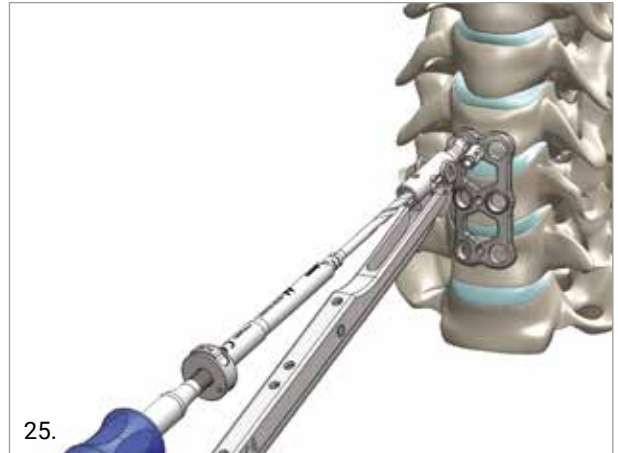

NOTICE: the depth of perforation is determined by the selected screw length and it is based on the required bone purchase. The Cervical Depth Gauge can be used to check the canal depth and to help determining the length of the cervical screw.



27.

CAUTION

The depth of perforation must be monitored by x-ray to avoid perforation of the posterior cortex.

WARNING

In case of sclerotic bone or any other reason that can cause high resistance during screw placement, bone preparation should be performed by using the provided tap.

CAUTION

Carefully tap at the desired length, as indicated by the scale on the tap shaft.



28.

WARNING

Bone preparation must be always performed both in primary and revision surgeries to prepare the correct hole trajectory and avoid screw mis-placement.

4.3 PLATE POSITIONING WITH THE SELF-DRILLING/SELF-TAPPING SCREWS

After the vertebral body has been prepared, the surgeon can plan for the cervical screw insertion. The length of the screw to be implanted is established in relation to the vertebral anatomy. Before starting to insert the screw,

assemble the Self-Retaining Screwdriver (fig.1): add the Retaining Sleeve (A) to the Screwdriver Main Body (B).

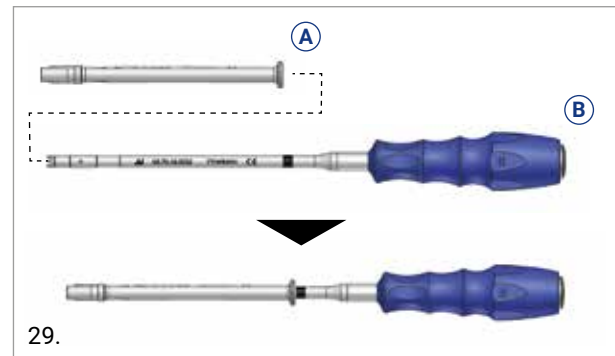

29.

The Self-Drilling/Self-Tapping screws can be inserted and fixed with the Self-Retaining Screwdriver specifically designed to easily align the screw and to avoid toggling. To couple the screw to the screwdriver-assembly retract the Retaining Sleeve backward and Insert the screwdriver tip into the screw head (fig.2A,B).

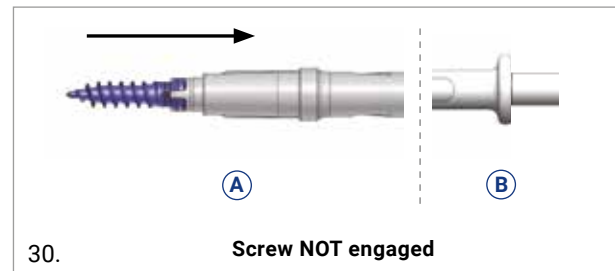

30.

Screw NOT engaged

Then, slide the Retaining Sleeve forward until full snap is reached in order to engage the screw head (fig.3A); the alignment of the marking line positioned on the shaft with the Retaining Sleeve indicates the proper matching with the screw (fig.3B).

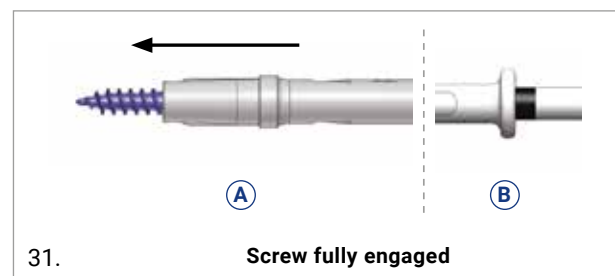

31.

Screw fully engaged

OPTION

To help coupling the bone screw to the Self Retaining Screwdriver use the Screw/Cage Loading Station. Insert the selected screw to the corresponding place in the rack depending on the length and the diameter. Holding the screw in place engage it to the Self-Retaining Screwdriver following the steps previously described (fig.4A,B); retract the Self Retaining Screwdriver-screw assembly as the insertion is fully accomplished.

The appropriate screw length can be verified using the Screw/Cage Loading Station (fig.4C).

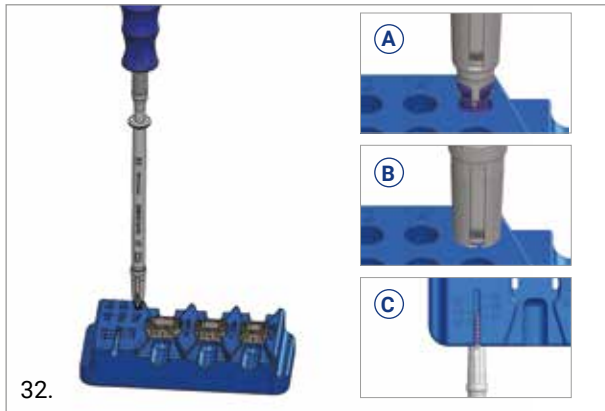

Once the screw is properly engaged with the Self-Retaining Screwdriver, insert the screw through the Mecta-C cervical plate hole until seated. Drill the remaining holes, measure and insert the remaining screws using the same technique.

CAUTION

When placing the screw, avoid to exert bending forces onto the Self Retaining screwdriver as these can result in screw and instrument damages.



CAUTION

As soon as the screw is seated into the Mecta-C plate hole, stop rotating as excessive tightening torque may result in unexpected failure.

OPTION

If necessary, the Screw Remover can be used to drive the screw(s) through the Mecta-C plate hole(s).

4.4 SCREW LOCKING

For the final locking of the pre-assembled screws, engage the Counter Torque to the Final Locking Screwdriver and tighten until a tactile sound indicates the final screw tightening has been achieved.

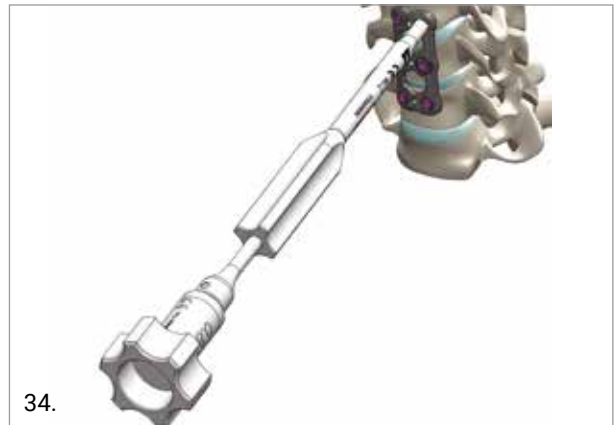

NOTICE: in order to achieve a correct coupling, proceed to insert the Final Screwdriver to the screw first (A); then slide the Counter Torque Sleeve to engage the bone screw (B).

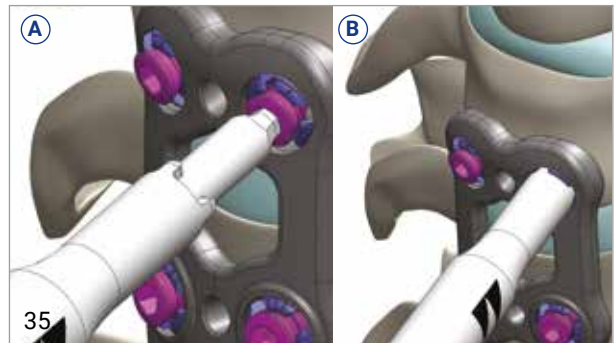

4.5 SCREW REMOVAL

In case of bone screw repositioning the Screw Removal can be performed with three different procedures depending on the stage of screw fixation.

Procedure 1 - If the final locking procedure has not been accomplished, and the Self-Retaining Screwdriver cannot be utilised, the Screw Remover should be used. To start the screw removal, position the distal tip of the Screw Remover until seated into the Bone Screw. Slide the sleeve forward to constrain the Locking Screw head and remove the screw by turning counterclockwise while pulling back the Screw-to-Screw Remover assembly.

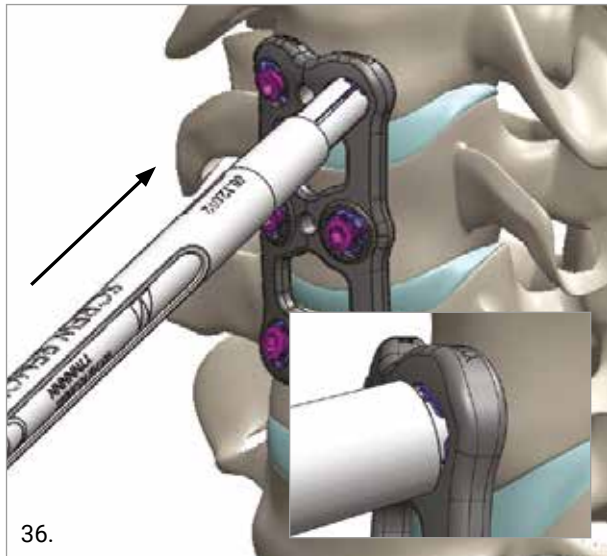

Procedure 2 - When the final locking procedure is completed the Counter Torque Final Locking Screwdriver assembly has to be used to unscrew the pre-assembled locking screw. The Self-Retaining Screwdriver has to be then used to remove the bone screw.

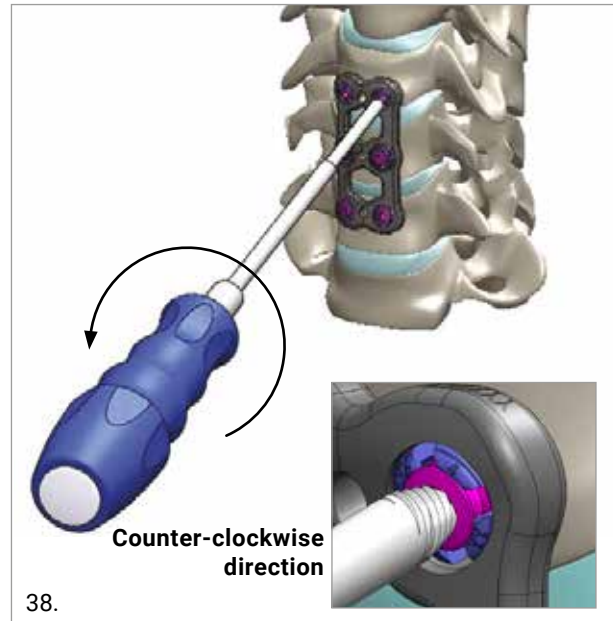

NOTICE: the locking screw extractor can be used to remove the screw in case the purple locking screw has been previously inadvertently disassembled

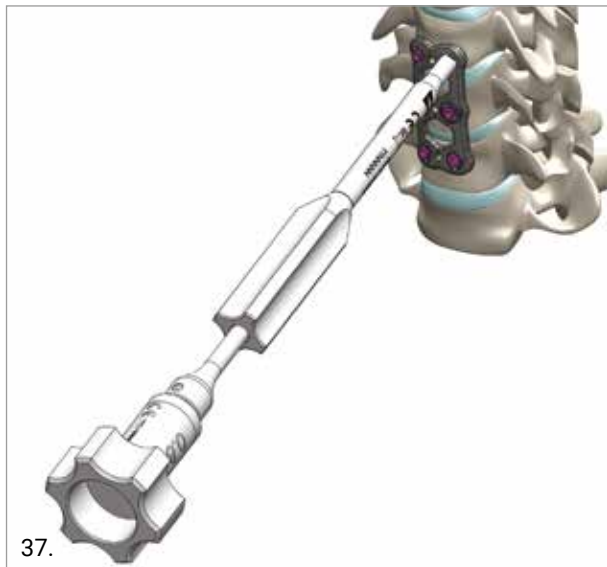

Procedure 3 - If the recess of the pre-assembled Locking screw is damaged and the final tightening is completed the Locking Screw Extractor must be used. Insert the Locking Screw Extractor into the hex recess of the Locking Screw applying a slight pressure and turn it counter-clockwise to remove the screw.

5. MODULAR RIGID SCREWDRIVER

A further option to insert the screws is the Modular Rigid Screwdriver. The following paragraphs describe the step to follow for a correct usage of the instrument.

5.1 BONE SCREW PREPARATION

Start preparing the Mecta Plate bone screws for the insertion. Place the Self-Drilling / Self-Tapping Screws in the dedicated holes, located in the Loading Station.

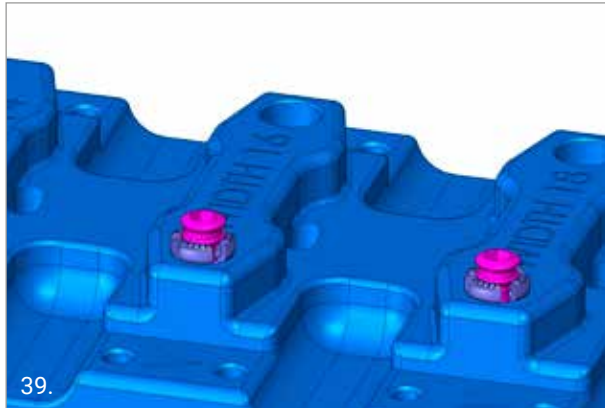

Attach the Counter Torque to the Final Locking Screwdriver and pull it all the way back until mechanical stop. The correct assembly is reached when the Final Screwdriver tip appears as shown in the picture below.

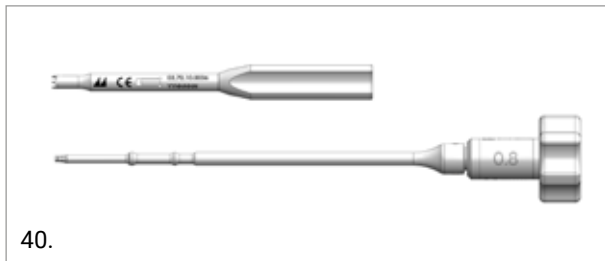

Insert the Final Screwdriver into the screw, slide the Counter Torque Sleeve to engage it and prepare to disassemble the Locking screw from the bone screw.

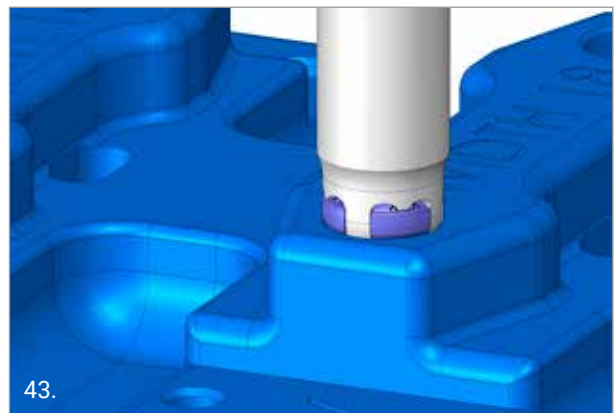
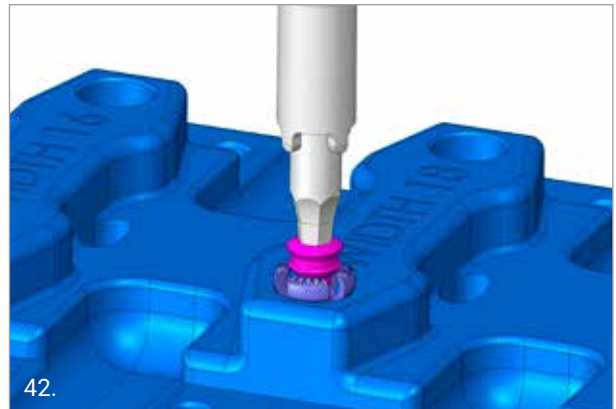

Unscrew the inner Locking Screw by rotating the Final Locking Screwdriver counter-clockwise, while preventing bone screw rotation, and place it in the dedicated area in the loading station.





45.

WARNING

Ensure the locking screws are placed in the correct locations; "V" identifies the location for the Variable Locking Screw and "F" identifies the location for the Fixed Locking Screw - do not mix these up.

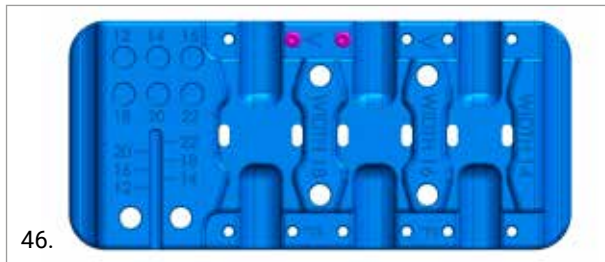

46.

5.2 MODULAR RIGID SCREW DRIVER PREPARATION

Before inserting the screw, assemble the Modular Rigid Screwdriver : insert the threaded inner shaft into the main body of the screwdriver until it reaches the mechanical stop.

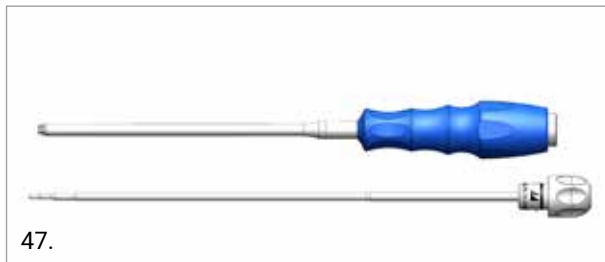

47.



48.

To couple the screw with the screwdriver, match the flanged outer sleeve with the bone screw and then slide the Inner Shaft through; to lock the screw, turn the Inner Shaft clockwise from the proximal knob until it reaches the mechanical stop.

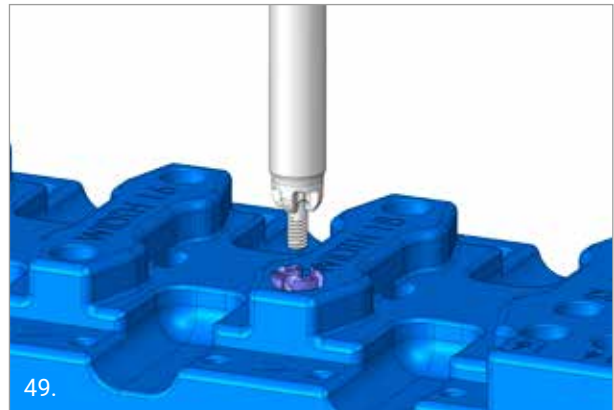

49.



50.



51.

CAUTION

While assembling the bone screw to the Modular Rigid Screwdriver, do not over torque the Inner Shaft to avoid damaging the screw or the screwdriver interface.

NOTICE: To attach the bone screw to the Modular Rigid Screwdriver use the Screw/Cage Loading Station. Insert the selected screw into the corresponding place in the rack depending on the length and diameter.

NOTICE: The proximal knob of the inner shaft must be "flush" with the handle to ensure the screw is engaged.

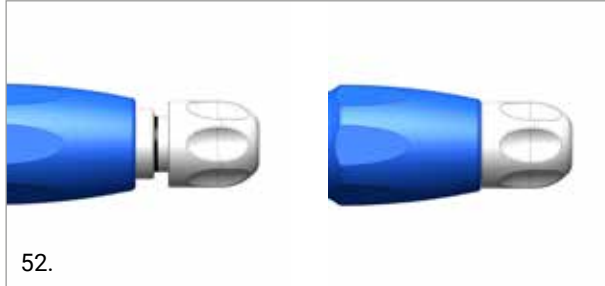

The appropriate screw length can be verified using the Screw/Cage Loading Station.

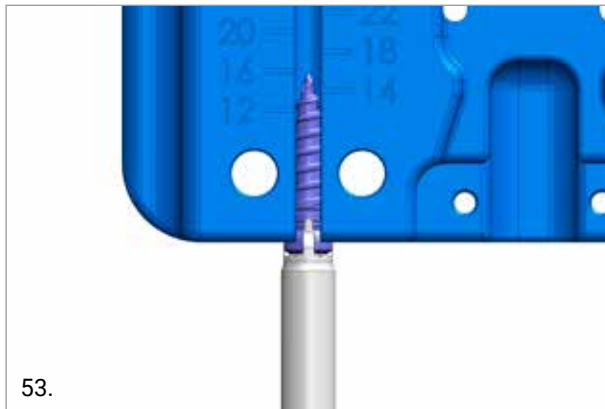

5.3 SCREW INSERTION

Once the screw is properly engaged with the Modular Rigid Screwdriver, insert it through the Mecta-C cervical plate hole until seated, then properly remove the Inner Shaft. Drill the remaining holes, measure and insert the remaining screws using the same technique.



CAUTION

When placing the screw, avoid to exert bending forces onto the Modular Rigid Screwdriver as this can result in screw and instrument damages.

CAUTION

When the screw is seated in the Mecta-C plate hole, stop rotating as over-tightening torque may result in an unexpected failure.

CAUTION

Be sure that the inner shaft is fully disengaged before removal of the Modular Rigid Screwdriver to avoid unexpected screw/screwdriver failure.

OPTION

If necessary, the Screw Remover can be used to drive the screw(s) through the Mecta-C plate hole(s).

To complete the bone screw positioning, insert the corresponding locking screw using the Final Locking Screwdriver or the Locking Screw Holder, to achieve a temporary loading of the locking screw onto the bone screw.

NOTICE: Use the screw holder to temporary fix the locking screw in the pre-assembled position. It cannot be used for final locking procedure.



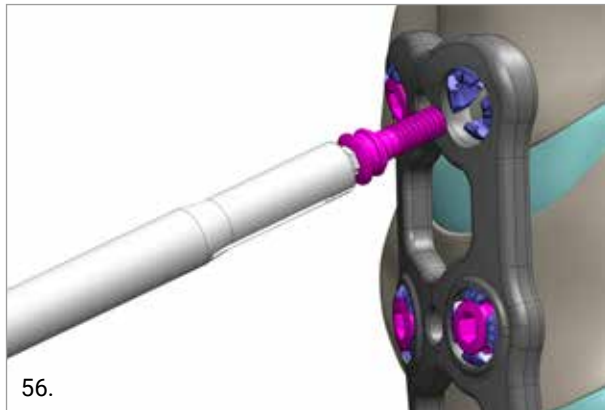

56.

CAUTION

Carefully inspect the locking screw insertion especially when using the Final Locking Screwdriver as its complete rotation (LOCKED Position) would lead to the screw final locking. A reasonable pre-final locking of the screw is achieved before the locking screw is flush with the bone screw upper head in the "PRE ASSEMBLED" position.

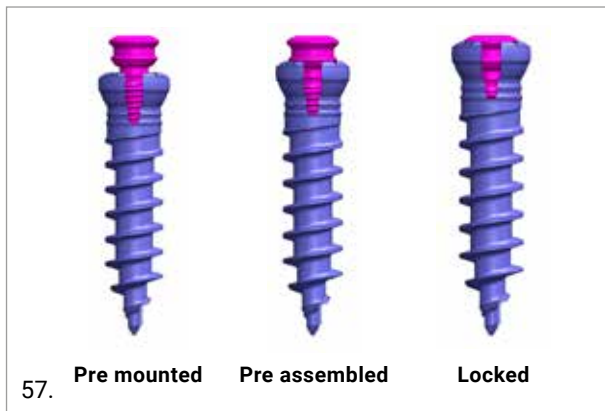

57.

Pre mounted Pre assembled Locked

CAUTION

Ensure the locking screw is coupled with the corresponding "fixed" or "variable" bone screw. Ensure the proper screw is selected.

Fixed screws



58.

The fixed screw design is identified by the partial anodization (dual color) of the screw shank.

NOTICE: For the fixed screw design the color of the Locking screw can be either violet or silver.

Variable screws

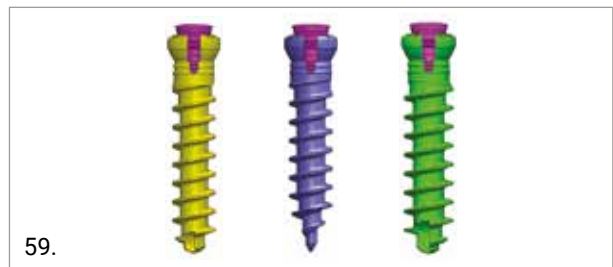

59.

The variable screw design is identified by a single color of the screw shank.



5.4 SCREW LOCKING

For the final locking follow the steps described in paragraph 4.4 SCREW LOCKING.



6. IMPLANTS NOMENCLATURE

6.1 STERILE PACKAGE



Anterior Cervical Plates

| REFERENCE | DESCRIPTION / FIGURE | LEVEL SIZE | LENGTH (mm) |
|-----------|---|------------|---|
| 03.70.120 |  | L1 | 20 |
| 03.70.122 | | | 22 |
| 03.70.124 | | | 24 |
| 03.70.126 | | | 26 |
| 03.70.128 | | | 28 |
| 03.70.130 | | | 30 |
| 03.70.132 | | | 32 |
| 03.70.134 | | | 34 |
| 03.70.234 | | |  |
| 03.70.237 | 37 | | |
| 03.70.240 | 40 | | |
| 03.70.243 | 43 | | |
| 03.70.246 | 46 | | |
| 03.70.249 | 49 | | |
| 03.70.252 | 52 | | |
| 03.70.352 |  | L3 | |
| 03.70.355 | | | 55 |
| 03.70.358 | | | 58 |
| 03.70.361 | | | 61 |
| 03.70.364 | | | 64 |
| 03.70.367 | | | 67 |
| 03.70.370 | | | 70 |
| 03.70.373 | | | 73 |
| 03.70.376 | | | 76 |
| 03.70.468 |  | L4 | 68 |
| 03.70.472 | | | 72 |
| 03.70.476 | | | 76 |
| 03.70.480 | | | 80 |
| 03.70.484 | | | 84 |
| 03.70.488 | | | 88 |
| 03.70.492 | | | 92 |

Variable Self-Drilling and Self-Tapping Screws ¹

| VARIABLE SELF-DRILLING SCREW | DESCRIPTION | | | VARIABLE SELF-TAPPING SCREW |
|---|-------------|-------------|------|---|
|  | | | |  |
| Reference | Size Ø mm | Length (mm) | Q.ty | Reference |
| 03.70.001 | 4 | 12 | 1 | 03.70.040 |
| 03.70.003 | | 14 | | 03.70.042 |
| 03.70.005 | | 16 | | 03.70.044 |
| 03.70.007 | | 18 | | 03.70.046 |
| 03.70.009 | | 20 | | 03.70.048 |
| 03.70.011 | | 22 | | 03.70.050 |
| 03.70.014 | 4 | 12 | 2 | 03.70.053 |
| 03.70.016 | | 14 | | 03.70.055 |
| 03.70.018 | | 16 | | 03.70.057 |
| 03.70.020 | | 18 | | 03.70.059 |
| 03.70.022 | | 20 | | 03.70.061 |
| 03.70.024 | | 22 | | 03.70.063 |

Fixed Self-Drilling and Self-Tapping Screws ¹

| FIXED SELF-DRILLING SCREW* | DESCRIPTION | | | FIXED SELF-TAPPING SCREW* |
|---|-------------|-------------|------|---|
|  | | | |  |
| Reference | Size Ø mm | Length (mm) | Q.ty | Reference |
| 03.70.140 | 4 | 12 | 1 | 03.70.260 |
| 03.70.142 | | 14 | | 03.70.262 |
| 03.70.144 | | 16 | | 03.70.264 |
| 03.70.146 | | 18 | | 03.70.266 |
| 03.70.148 | | 20 | | 03.70.268 |
| 03.70.150 | | 22 | | 03.70.270 |
| 03.70.153 | 4 | 12 | 2 | 03.70.273 |
| 03.70.155 | | 14 | | 03.70.275 |
| 03.70.157 | | 16 | | 03.70.277 |
| 03.70.159 | | 18 | | 03.70.279 |
| 03.70.161 | | 20 | | 03.70.281 |
| 03.70.163 | | 22 | | 03.70.283 |

¹ Additional sizes available on demand

*The Locking screw can be either violet or silver

Variable and fixed Self-Tapping Screws ¹

| VARIABLE SELF-TAPPING SCREW | DESCRIPTION | | | FIXED SELF-TAPPING SCREW* |
|---|-------------|-------------|------|---|
|  | | | |  |
| Reference | Size Ø mm | Length (mm) | Q.ty | Reference |
| 03.70.078 | 4.5 | 12 | 1 | 03.70.390 |
| 03.70.080 | | 14 | | 03.70.392 |
| 03.70.082 | | 16 | | 03.70.394 |
| 03.70.084 | | 18 | | 03.70.396 |
| 03.70.086 | | 20 | | 03.70.398 |
| 03.70.088 | | 22 | | 03.70.400 |
| 03.70.092 | 4.5 | 12 | 2 | 03.70.404 |
| 03.70.094 | | 14 | | 03.70.406 |
| 03.70.096 | | 16 | | 03.70.408 |
| 03.70.098 | | 18 | | 03.70.410 |
| 03.70.100 | | 20 | | 03.70.412 |
| 03.70.102 | | 22 | | 03.70.414 |

¹ Additional sizes available on demand

*The Locking screw can be either violet or silver

Part numbers subject to change.

NOTE FOR STERILIZATION

The instruments are not sterile upon delivery. Instruments must be cleaned before use and sterilized in an autoclave respecting the US regulations, directives where applicable, and following the manufactures instructions for use of the autoclave. For detailed instructions please refer to the document "Recommendations for cleaning decontamination and sterilization of Medacta® International reusable orthopaedic devices" available at www.medacta.com.



**REDEFINING BETTER
IN ORTHOPAEDICS
AND NEUROSURGERY**

MEDACTA.COM



Medacta International SA
Strada Regina - 6874 Castel San Pietro - Switzerland
Phone +41 91 696 60 60 - Fax +41 91 696 60 66
info@medacta.ch

Find your local dealer at: medacta.com/locations

All trademarks and registered trademarks are the property of their respective owners.
This document is intended for the US market.

Mecta-C Plate
Surgical Technique

ref: 99.44CP.12US
rev. 04

Last update: July 2018
CE 0476