

TROLLEY

A passive growth-guiding solution

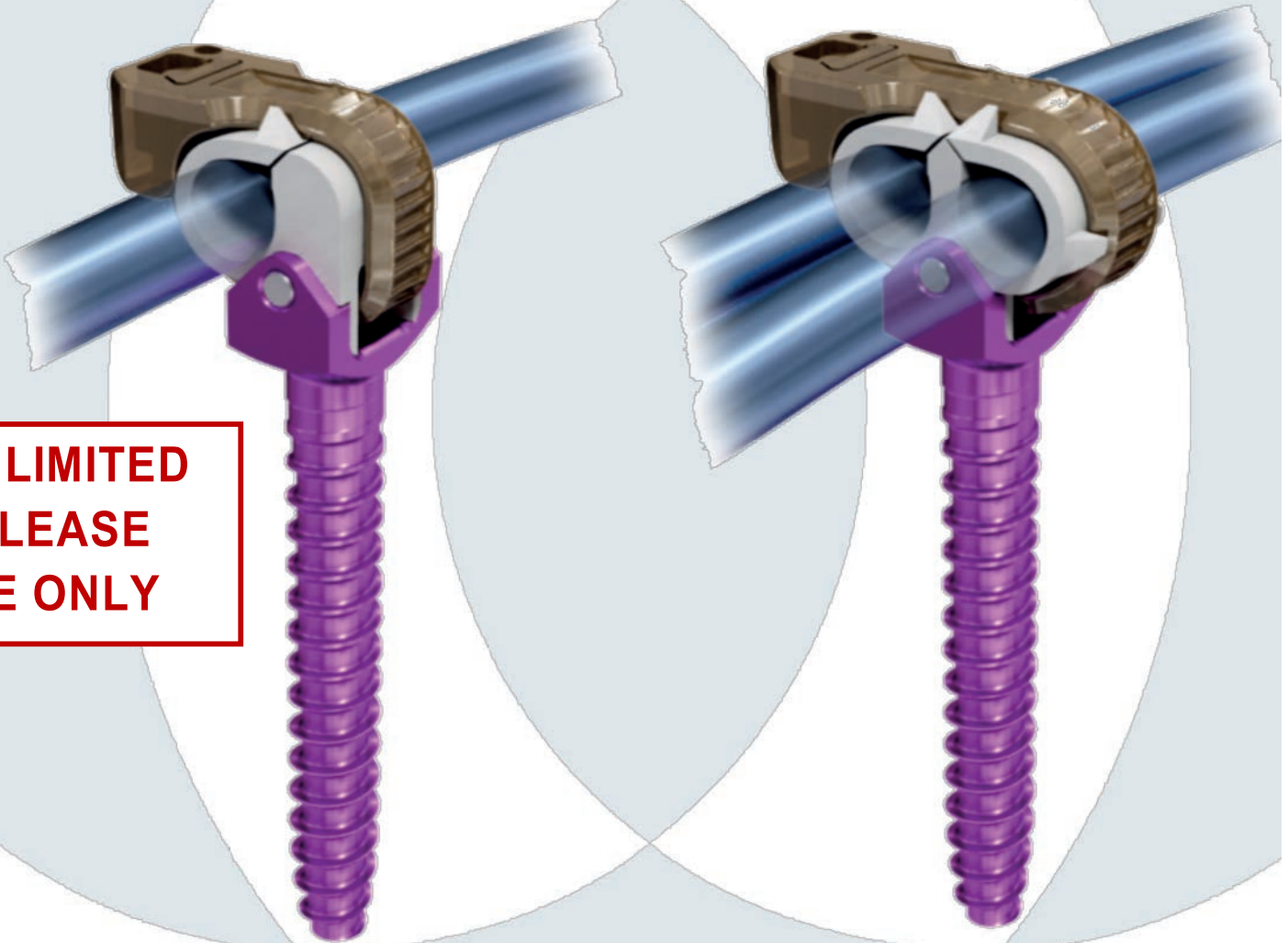

**FOR LIMITED
RELEASE
USE ONLY**

This publication is not intended for distribution in the USA.

SURGICAL TECHNIQUE

 Image intensifier control

This description alone does not provide sufficient background for direct use of DePuy Synthes products. Instruction by a surgeon experienced in handling these products is highly recommended.

Processing, Reprocessing, Care and Maintenance

For general guidelines, function control and dismantling of multi-part instruments, as well as processing guidelines for implants, please contact your local sales representative or refer to:

<http://emea.depuysynthes.com/hcp/reprocessing-care-maintenance>

For general information about reprocessing, care and maintenance of Synthes reusable devices, instrument trays and cases, as well as processing of Synthes non-sterile implants, please consult the Important Information leaflet (SE_023827) or refer to:

<http://emea.depuysynthes.com/hcp/reprocessing-care-maintenance>

TABLE OF CONTENTS

INTRODUCTION	TROLLEY Implants and Instruments	2
	Concept and Introduction	4
	Precautions and Warnings	6
	Indications & Contraindications	8
	Construct Options	9
SURGICAL TECHNIQUE	Preparation and Approach	11
	Screw Insertion	13
	Rod Insertion	20
	Final Tightening	26
	Finalize Construct	31
	Continuum of Care	32
	Additional Implants for further Stabilization	33
	Components Assembly	34
	Removal of TROLLEY Gliding Vehicle	36
PRODUCT INFORMATION	Assembly / Disassembly Instructions	37
	Implants	38
	Instruments	40
	TROLLEY Instrument Set	41

TROLLEY IMPLANTS AND INSTRUMENTS

TROLLEY GLIDING VEHICLE

IMPLANTS

TROLLEY growth-guiding solution

The TROLLEY solution is designed to allow for **continued passive spinal growth** along the rods **reducing the number of lengthening surgeries** and therefore, **the overall morbidity** of growth-friendly surgeries.

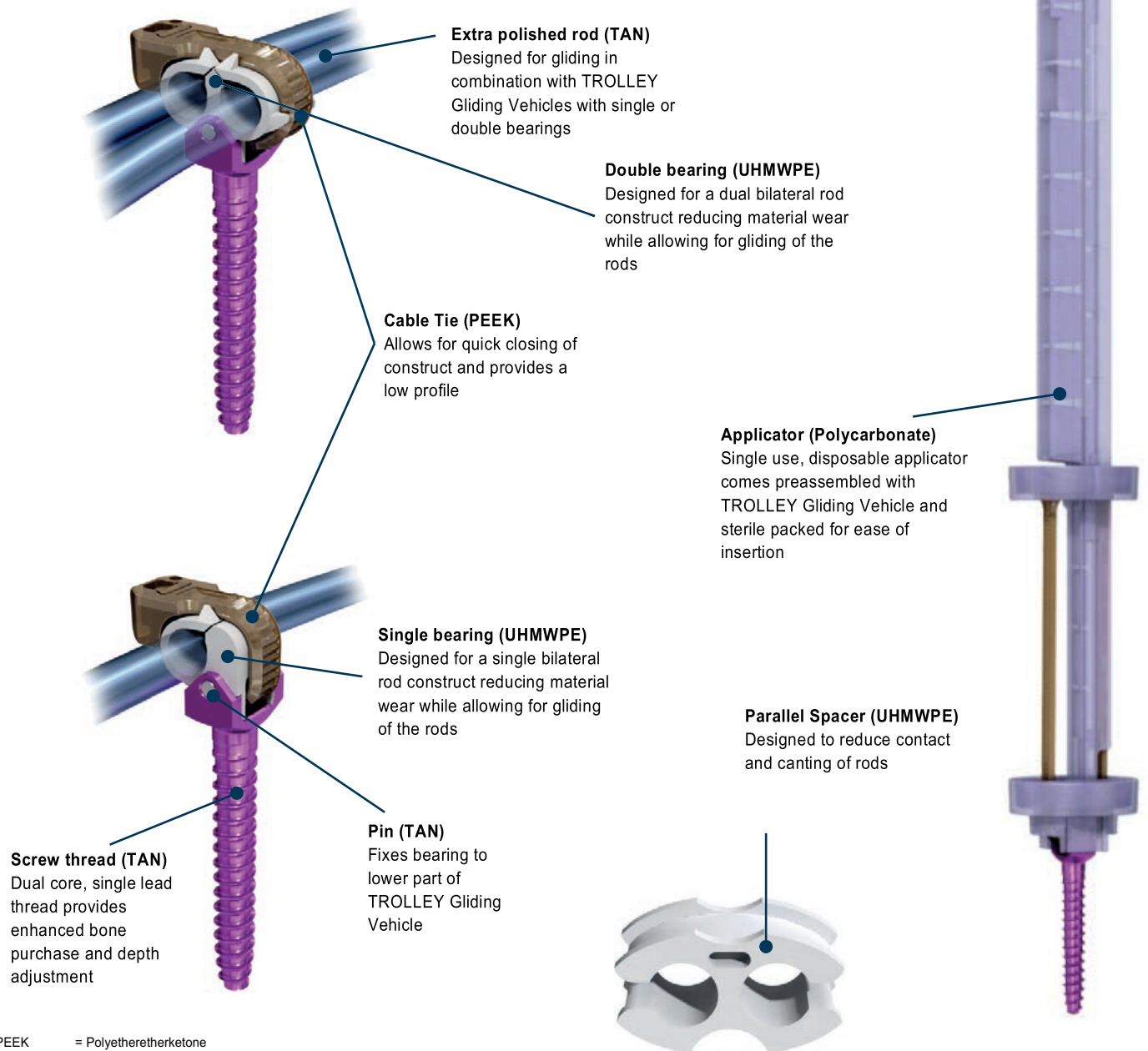

PEEK = Polyetheretherketone
 TAN = Titanium Alloy
 UHMWPE = Ultra-High Molecular Weight Polyethylene

INSTRUMENTS

5 steps to insert and final close a TROLLEY Gliding Vehicle (TROLLEY GV)

- A Insert TROLLEY GV with TROLLEY Screwdriver
- B Use the Alignment Tool to rotate and align the TROLLEY GV with the planned rods trajectory
- C Close Cable Tie(s) by hand
- D Final tighten Cable Tie with Cable Tie Pusher and Forceps for Cable Tie while reducing rod with Double Rod Pusher
- E Cut off the overlapping part of the Cable Tie with Cable Tie Cutter

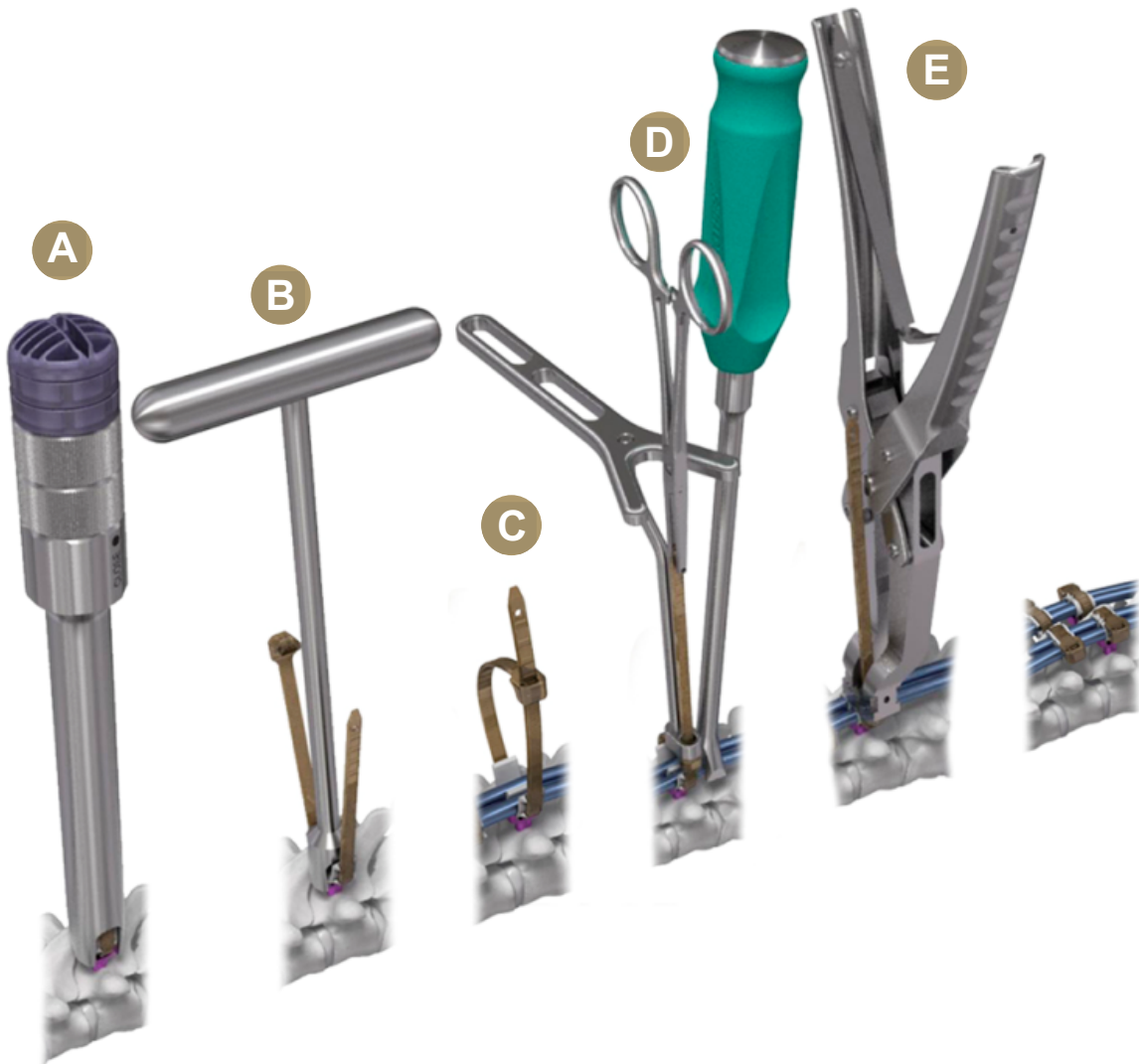

CONCEPT AND INTRODUCTION

CONCEPT

The TROLLEY passive growth-guiding solution is based on the concept introduced by Eduardo R. Luque (Luque, 1982*) to guide spinal growth along a given trajectory. However, TROLLEY allows for the application of a growth-guiding construct without the use of sublaminar or cerclage wires:

- Guides growth following physiological sagittal alignment
- Implant design allows gliding of the rod at the TROLLEY GV / rod interface
- May reduce spontaneous fusion by keeping the rod at a distance from the bone

TROLLEY is a passive growth-guiding system including specific instruments and implants (TROLLEY GVs, Cable Ties, Parallel Spacers and extra polished rods) to provide spinal deformity correction and to allow for growth of the children's immature spine.

The implants provide the flexibility to accommodate a wide range of pathologies and variations in patient anatomy for the scoliotic immature thoracolumbar spine (see pages 9 and 10 for "Construct Options").

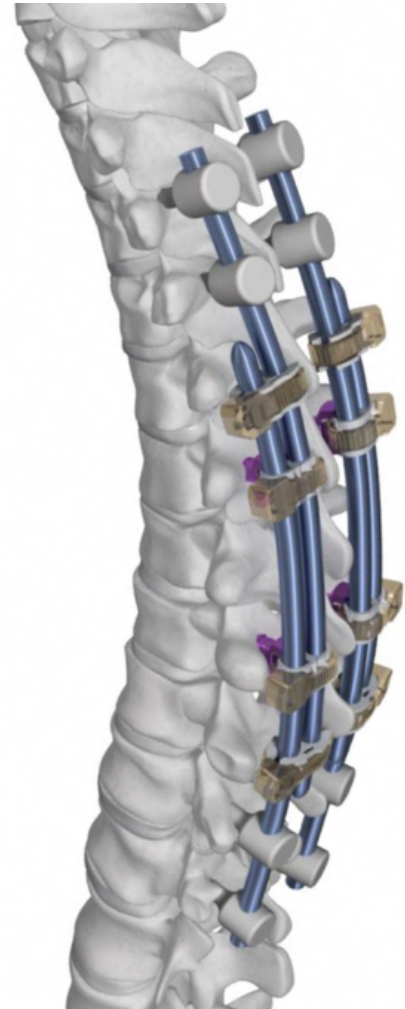

* Luque, E.R. (1982): The Anatomic Basis and Development of Segmental Spinal Instrumentation. Spine 7 (3), 256-259

INTRODUCTION

Early-Onset Scoliosis (EOS) may have multiple causes and severe consequences. Severe spinal deformities and early spinal fusions may hinder pulmonary development of the lungs which is the primary morbidity associated with EOS that reduces life expectancy (Campbell, R.M. et al, 2004*).

If traditional, conservative treatment options such as monitoring, bracing, casting are not feasible (respiratory compromise, neuromuscular etiology, compliance of wearing the brace) or are simply not successful (malignant curve progression), then surgical management should be considered. To reduce the risk of definitive early fusion in young patients (<10 years of age), surgical techniques and technologies have evolved over the last years to manage EOS.

The core challenge when managing EOS is the ability to prevent curve progression while maintaining longitudinal spinal growth. The growth-guiding system TROLLEY has been designed to reduce the need for repetitive lengthening surgeries, to provide a low profile system and to reduce the risk of spontaneous fusion by keeping the rods away from the bony spinal elements.

*Campbell, R.M., Jr., Smith, M.D., Mayes, T.C., Mangos, J.A., Willey-Courand, D.B., Kose, N., Pinero, R.F., Alder, M.E., Duong, H.L., and Surber, J.L. (2004). The effect of opening wedge thoracostomy on thoracic insufficiency syndrome associated with fused ribs and congenital scoliosis. *J. Bone Joint Surg. Am.* 86-A, 1659-1674.

PRECAUTIONS AND WARNINGS

PRECAUTIONS

The TROLLEY implants and instruments are an addition to the indicated pedicle screw systems below. TROLLEY Gliding Vehicles (TROLLEY GVs) need to be used in conjunction with indicated pedicle screws and hooks within the thoracolumbar spine.

Indicated Pedicle Screw Systems	Rod Diameter
USS Small Stature/Pediatric and USS II	Ø 5.0 / Ø 6.0 mm
Pangea	Ø 6.0 mm
URS	Ø 6.0 mm

To reduce the risk of spontaneous fusion, ensure to skip minimum one level between:

- the TROLLEY GVs
and
- the TROLLEY GVs and the fixed spinal anchors

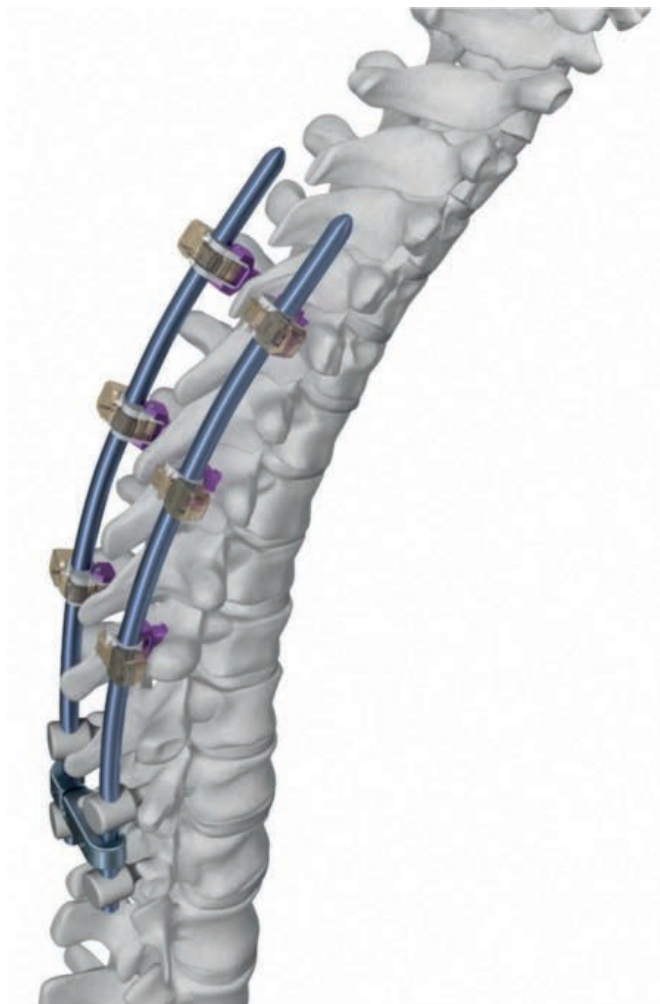

WARNINGS

Despite TROLLEY GVs having a low profile, patients may require additional wound or skin protection to prevent inadvertent rubbing or bumping of prominent implants. Overlying skin protection is recommended, so patients should initially wear a protective dressing, padding or brace on the skin overlying the implants in order to prevent rubbing or bumping of the skin, which may lead to skin breakdown. Monitoring for skin breakdown decreases the risk of deep infections. Patients with a diagnosis of spina bifida need additional surveillance due to their decreased levels of sensation.

In addition to the general risks associated with spinal surgery, EOS patients undergoing this procedure have the potential to experience a high rate of complications including, but not limited to rod fracture, screw loosening/pull-out or spontaneous fusion.

It is important to note that EOS patients who receive TROLLEY will need careful ongoing monitoring and may require additional surgery.

INDICATIONS & CONTRAINDICATIONS

INTENDED USE

TROLLEY is a posterior passive growth-guiding solution placed in the thoracolumbar spine. It is used in combination with spinal anchors and helps to provide deformity correction of the scoliotic immature spine while allowing for continued spinal growth.

INDICATIONS

Progressive scoliosis with remaining growth of the spine

CONTRAINDICATIONS

- Rigid, non-flexible spine
- Pedicles too small for pedicle screw implantation
- Skeletally mature
- Insufficient soft tissue to allow for proper skin coverage of implant
- Poor nutrition status

CONSTRUCT OPTIONS

Disclaimer: all construct images are shown for illustrative purposes only and do not necessarily represent the exact final constructs.

FOUR-ROD TECHNIQUE

- Requires proximal and distal fixed anchors expected to produce local fusion
- Instrument the apex of the deformities with TROLLEY GVs to achieve maximal apical translation
- Growth potential stored in central telescopic, overlapping portion
- Parallel Spacers are designed to reduce convergence of the two parallel rods

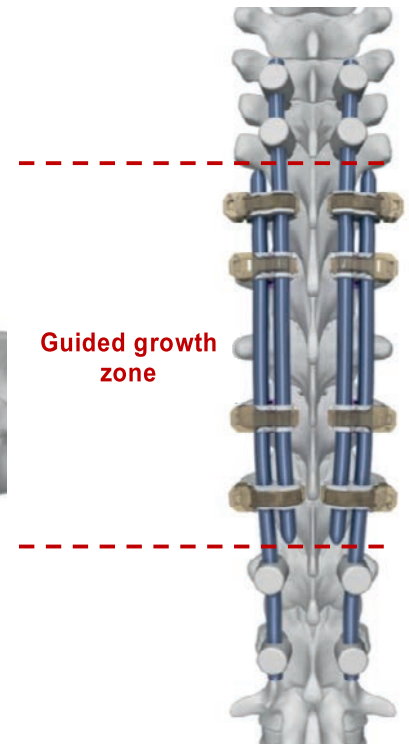
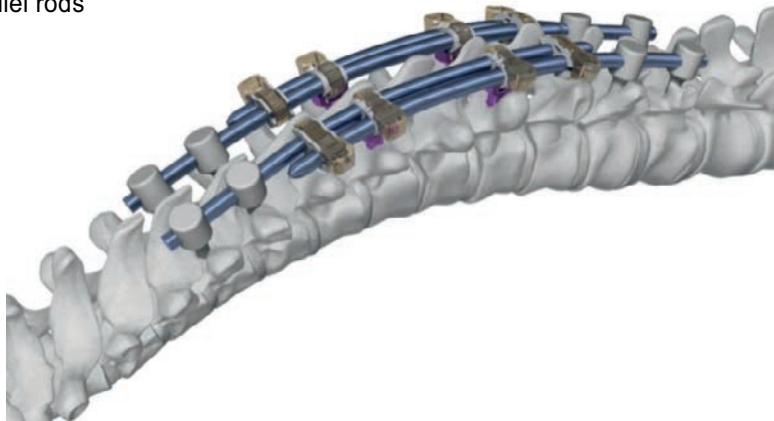

TWO-ROD TECHNIQUES

1. Apical fusion

- Requires apical fusion with fixed anchors allowing for apical deformity correction, apical derotation. Number of level fused related to severity of deformity
- Inserted pairs of TROLLEY GV two to three vertebrae away from apex proximally and distally allowing for guided growth
- Growth potential is stored in the length of rod beyond the most proximal and distal TROLLEY GV

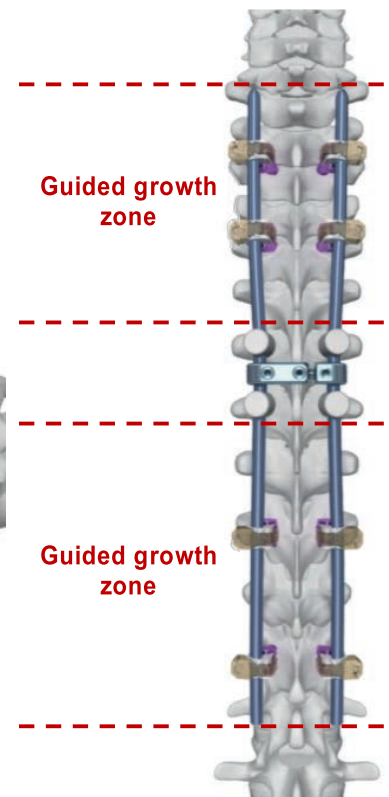
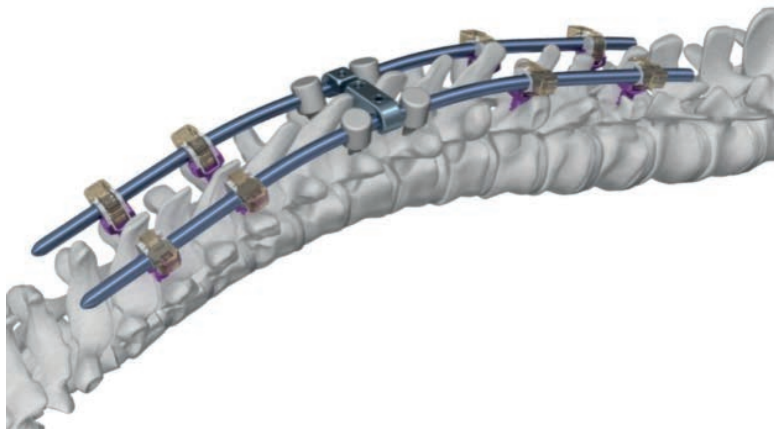

2. Distal fusion

- Requires solid distal fixation and fusion typically including pelvis and / or lumbar vertebra
- Growth potential stored in length of rod proximal to the last proximal TROLLEY GV
- Larger diameter rod may be recommended for neuromuscular pathologies if patient anatomy permits

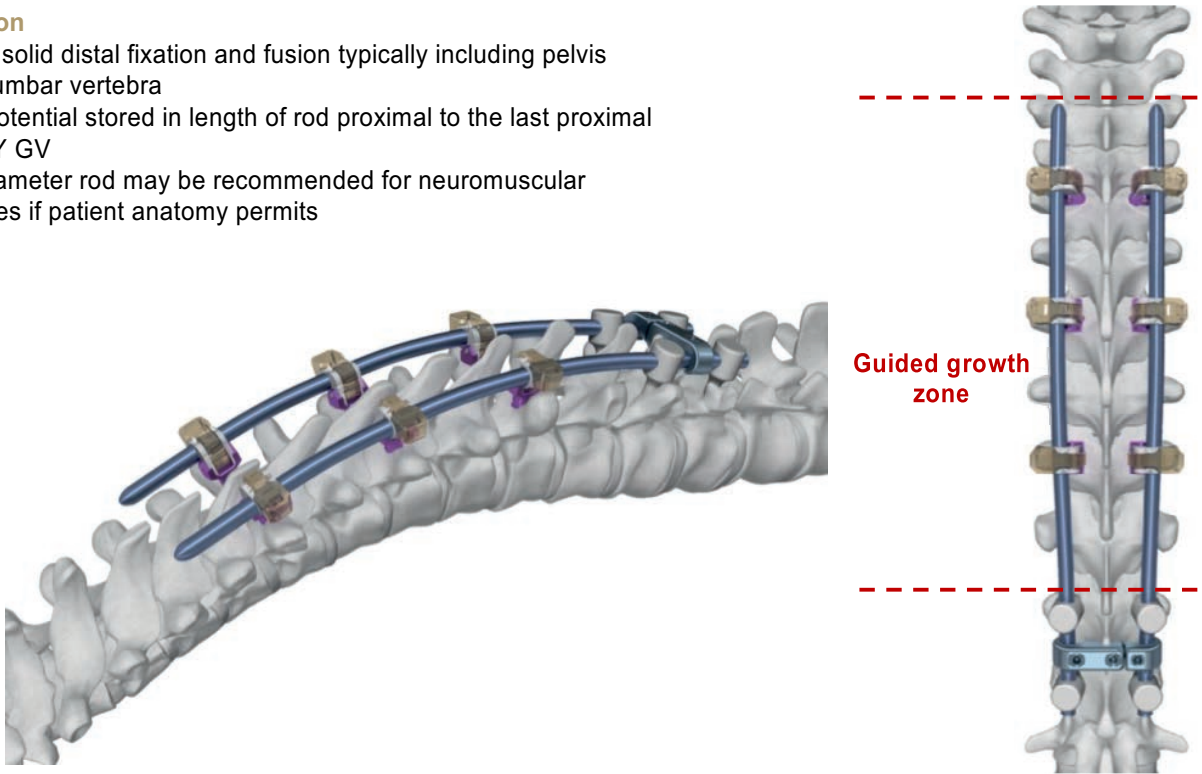

PREPARATION AND APPROACH

1

Preparation

Required sets

01.625.002	TROLLEY Instrument Set
01.625.001S	TROLLEY Implant Set
and 187.260	USS Small Stature/Pediatric General Instruments
187.263	USS Small Stature/Pediatric Pedicle Screws (Titanium)
187.267	USS Small Stature/Pediatric Hooks (Titanium)
or 187.223	USS-II Pedicle Screws (Titanium)
187.233	USS-II Hooks (Titanium)
187.218	Transverse Connectors low profile, for Rods Ø 6.0 mm
or 01.636.001	Universal Reduction Screws in Vario Case™, size 1/1
01.636.002	Universal Reduction Screws in Vario Case™, size 1/2
01.636.012	Instruments for Universal Reduction Screw in Vario Case™
or 01.689.001	Set for URS Degen Instruments and Implants
01.689.002	Set for URS Degen General Instruments
01.689.003	Set for URS Degen Additional Instruments
Various numbers	Pangea

The standard TROLLEY set in combination with one of the indicated pedicle screw systems contain the required implants and instruments to perform the procedure.

Have the required sets readily available prior to the surgery.

Have all necessary imaging readily available to plan construct type, implant placement, incision approach and to identify individual patient anatomy.

2

Approach

Make a midline incision spanning segments of spine to be instrumented. Three smaller midline incisions may also be used.

For fixed spinal anchors, insert spinal fixation through classic subperiosteal dissection as these segments will be fused. Please refer to the surgical technique guide of the corresponding pedicle screw systems.

For the insertion of TROLLEY Gliding Vehicles (TROLLEY GVs) use a transmuscular approach, sparing joints and minimizing bony exposure to reduce the risk of spontaneous fusion. At the thoracic levels, use a lateral to midline erector spinae* insertion technique, dissecting directly onto the transverse process, avoiding exposure of the lamina.

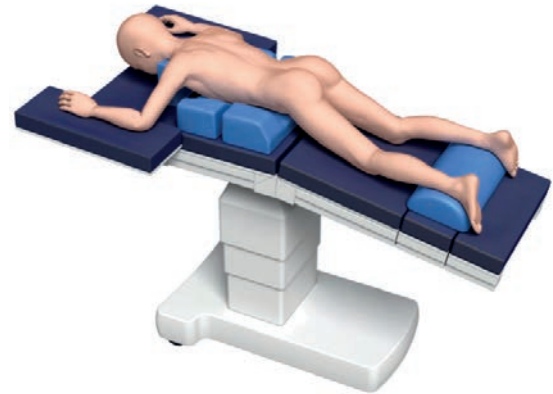

- ☞ Use of fluoroscopic guidance to confirm pedicle entry point is crucial.

Notes:

- * Dissection at the area where TROLLEY GVs are to be inserted should be kept at a minimum, using extra-periosteal and muscle sparing techniques to reduce the risk of spontaneous fusion (Ouellet, J. (2011). Surgical technique: Modern Luque Trolley, a self-growing rod technique. Clinical orthopaedics and related research 469, 1356-1367.)
- Additionally, the depth of the TROLLEY GV is crucial. If left too superficial, skin breakdown may occur. Conversely, if TROLLEY GVs are inserted too deep, the rods will be resting on the bone or facet joints above and below, increasing the risk of early spontaneous fusion

SCREW INSERTION

1

Perforate cortex of pedicle and prepare for insertion

Locate pedicles and use the Awl of the corresponding screw diameter from the chosen pedicle screw system to perforate the cortex. Use the Probe of the corresponding screw diameter to open the pedicle canal. Alternatively, taps can be used to perform this procedure.

- Using radiographic imaging, confirm the pedicle location, orientation and depth. When selecting the appropriate length of the TROLLEY GV, use the markings on the Probe to determine the pedicle depth. Use the Feeler to check pedicle canal integrity prior to insertion of the TROLLEY GV.

Notes:

- Do not use the Pedicle Awl or the Pedicle Probe for any screws that are smaller or bigger than the corresponding size
- Additional care must be taken as EOS patients tend to have small pedicles. Therefore, the use of radiographic imaging is crucial to locate pedicles and to reduce the risk of malpositioned screws
- Screw entry points between levels should deviate as little as possible. This will ensure good alignment of the TROLLEY GV and reduce stresses in the final construct. Keeping the rods parallel to each other is an important factor to allow guided growth

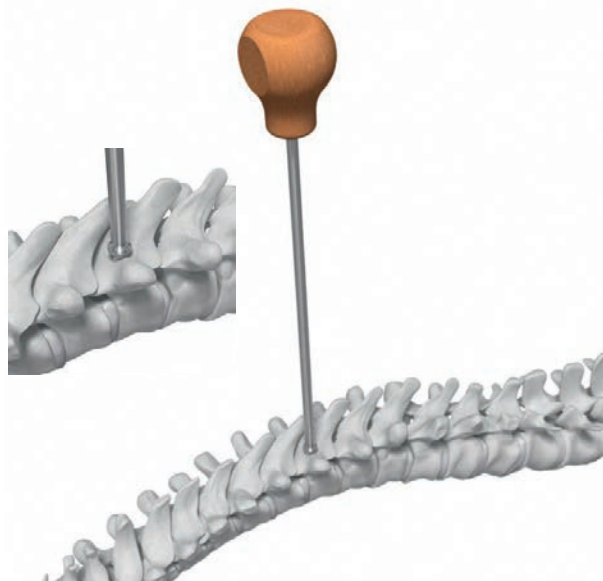

2

TROLLEY GV Selection

TROLLEY GVs are placed at strategic points across the deformity based on curve patterns and construct type used.

Refer to the section “Construct Options” (pages 9 and 10) to choose the proper approach according to the region of the spine for TROLLEY GV placement.

Choose the corresponding TROLLEY GV, either with single or double bearing.

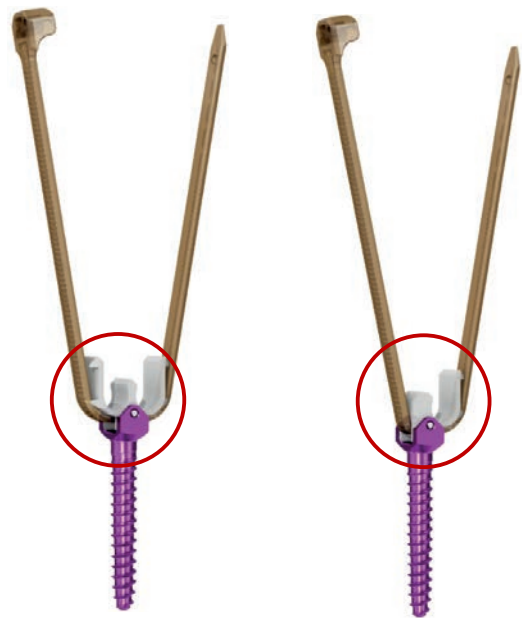

**TROLLEY GV with
double bearing**

**TROLLEY GV with
single bearing**

3

Assemble TROLLEY Screwdriver to TROLLEY GV

Instruments

03.625.001 TROLLEY Screwdriver

All TROLLEY GVs will be delivered in sterile packaging. Assemble the TROLLEY Screwdriver with the unpacked TROLLEY GVs with applicator. The correct orientation of the screw portion is ensured by the driver geometry (1). The TROLLEY GV with applicator is introduced into the Screwdriver by pushing it into the guide (2). Push the applicator into the Screwdriver until it is completely inserted (3).

Once the TROLLEY GV with applicator is fully inserted, lock it into place by turning the wheel on the Screwdriver clockwise into the "CLOSE" position (4).

Precaution: The TROLLEY Screwdriver (03.625.001) can only be used with TROLLEY GVs.

Note: Make sure the TROLLEY Screwdriver is in the "OPEN" position prior to TROLLEY GV insertion.

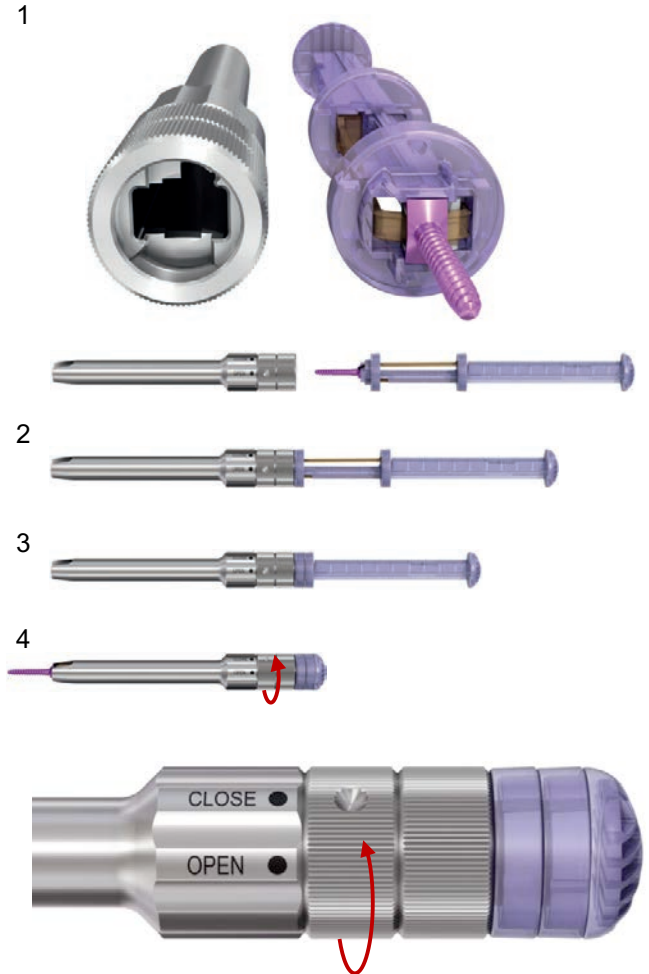

4

Insert TROLLEY GVs

Instruments

03.625.001 TROLLEY Screwdriver

The TROLLEY GV can now be inserted into the prepared pedicle under fluoroscopic control. Advance the TROLLEY GV until it is just slightly above the bony surface. The depth of screw insertion can be determined by looking at the skin level.

The orientation of the Cable Tie lock is given by the pictogram on top of the TROLLEY GV applicator (1). The lock on the pictogram should look towards the midline to ensure that in the closed position the lock is placed lateral.

Visibility in the wound can be increased by slightly pulling up the Screwdriver. For backing up the Screwdriver, make sure you do not completely release the Cable Tie from the applicator.

Notes:

- The TROLLEY GVs are self-tapping pedicle screws however, if tapping is preferred, use the appropriate Tap and Tap Handle of indicated pedicle screw systems
- Make sure to keep the operation site free of disturbing soft tissues

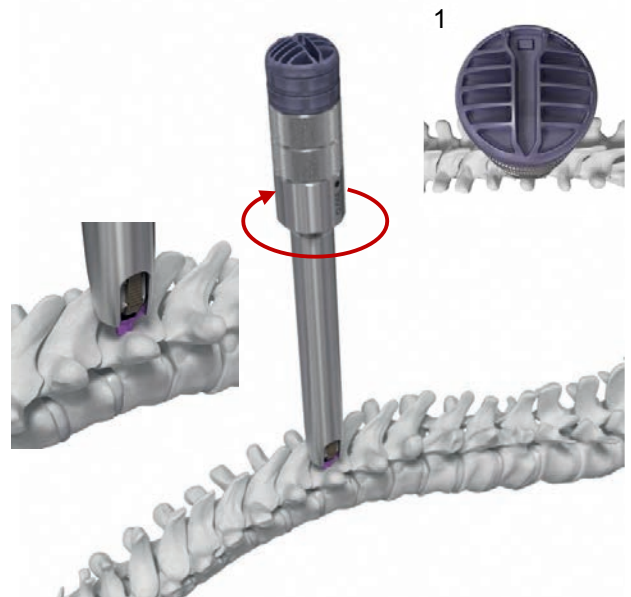

5

Remove TROLLEY Screwdriver

Instruments

03.625.001	TROLLEY Screwdriver
------------	---------------------

The TROLLEY Screwdriver can be removed by simply pulling on the instrument. The applicator of the TROLLEY GV will be removed within the same step.

To remove the applicator from the TROLLEY Screwdriver turn the wheel on the Screwdriver counterclockwise to the "OPEN" position (1) and pull out the applicator (2). The single use applicator can then be disposed.

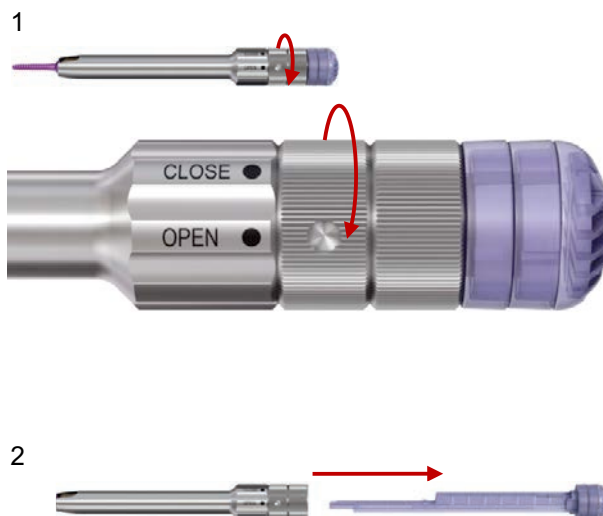
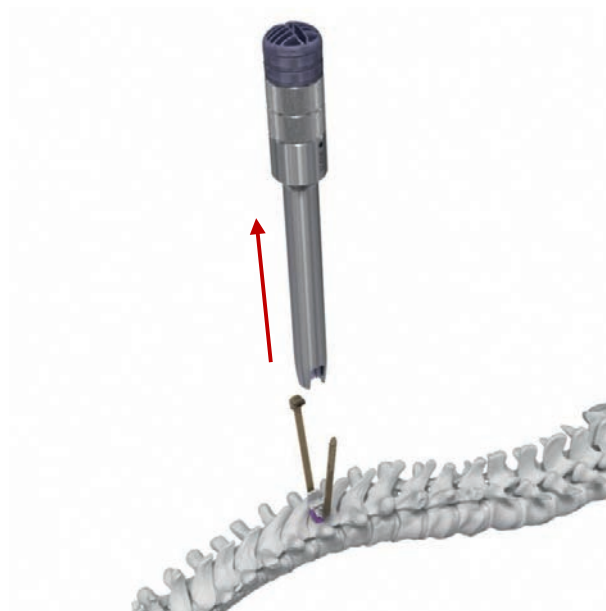

6

Insert remaining TROLLEY GVs

Instruments

03.625.001	TROLLEY Screwdriver
------------	---------------------

Continue inserting the remaining TROLLEY GVs by repeating the previous steps 1-5.

Notes:

- Make sure to insert the remaining TROLLEY GVs appropriately to allow rod insertion
- To reduce the risk of spontaneous fusion ensure to skip minimum one level between the TROLLEY GVs

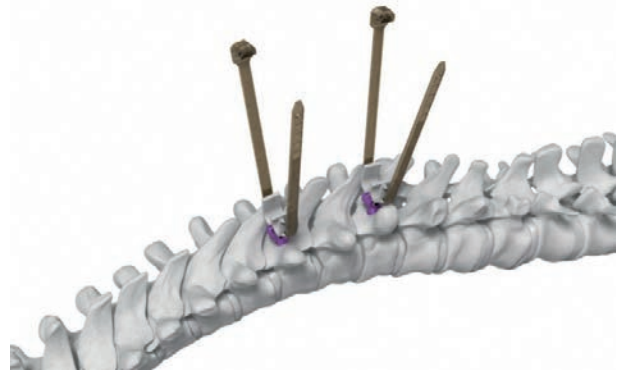

7

Align TROLLEY GVs

Instruments

03.625.005 TROLLEY Alignment Tool

For orientation and depth adjustment of the TROLLEY GV pedicle screw, the TROLLEY Alignment Tool is placed over the Cable Tie and rod bearing onto the screw portion of the TROLLEY GV.

Notes:

- Orientation and depth adjustment is crucial to ensure ease of Cable Tie closure. If the TROLLEY GV bearing surface is not aligned to the rod then Cable Tie closure may be difficult and may result in asymmetrical wear of the bearing. This is particularly important when using a TROLLEY GV with double bearing
- Depth adjustment is particularly important for TROLLEY GV in adjacent vertebrae as a difference in depth may lead to difficulties in closing the Cable Tie
- Ideally, the Cable Tie lock is placed lateral in the final position. A midline position for the lock is not recommended due to potential conflicts with the spinous processes
- Always check if the Cable Tie is mobile before insertion of the rod (1)

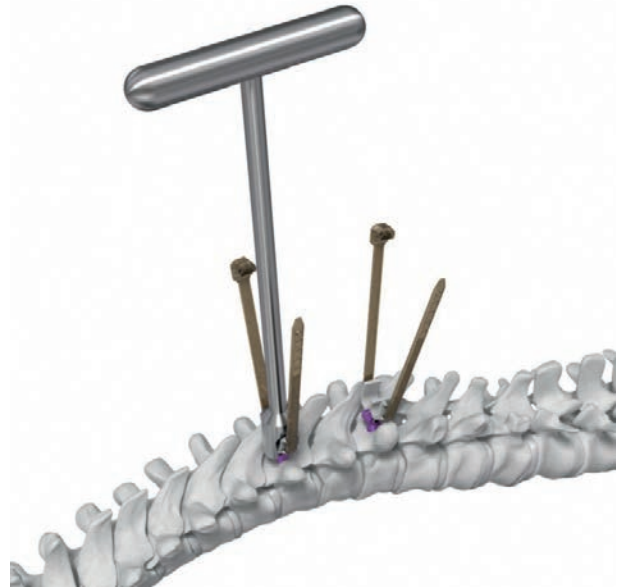

1

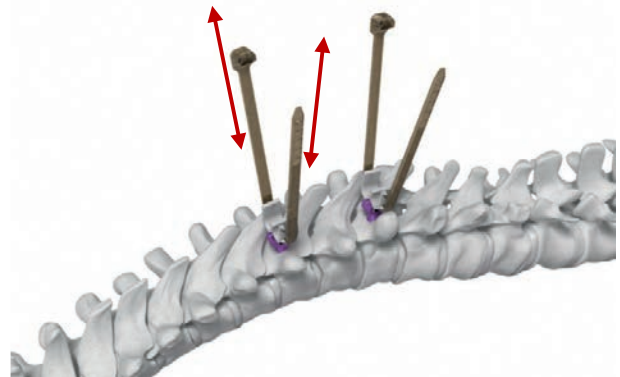

ROD INSERTION

Precautions:

- Insert remaining fixed spinal anchors according to chosen construct type prior to rod insertion
- Select appropriate rod diameter (\varnothing 5.0/6.0 mm) depending on chosen pedicle screw system and patient anatomy
- For larger, neuromuscular patients a \varnothing 6.0 mm might be beneficial

Note: To reduce the risk of spontaneous fusion ensure to skip minimum one level between the TROLLEY GVs and the fixed spinal anchors

1

Determine rod contour and length

Determine required length and cut the rod to length according to expected growth and patient anatomy with a universal 5.0/6.0 mm Rod Cutter.

Notes:

- Choose appropriate rod length to allow for growth of the spine without significant soft tissue disturbance
- Make sure to cut the rods appropriately at the flat end to reduce the risk of sharp rod ends (do not cut the rod at the blunt tip end as this is important to ease rod tunneling)
- Bend the rods to match the spinal anchor locations
- Bend the rods in respect to the expected growth potential (for TROLLEY GVs)
- Rod contouring needs to be done carefully to produce smooth curves and to avoid any notches

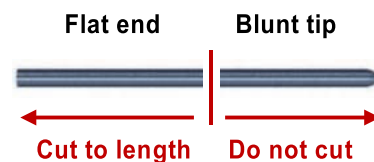

2a Four-rod technique

Contour and insert rods

Contour the polished rods according to your preferred sagittal profile (planned curve correction) and cut the rods (attached at proximally fixed anchors) to travel the length of the spine till they just reach the distally fixed anchors. Similarly, the rods (attached at the distally fixed anchors) should travel just proximal to the proximal fixed anchors.

Insertion of the rods can be done either from the proximal or distal incision, tunneling the blunt tip towards the middle incision and engaging the TROLLEY GV bearing. Using the sagittal curve of the rods, they can be rotated partially facilitating the insertion of the rods and capturing the spinal implants.

The rods should be passed subfascially, without touching any bony surface.

Precautions:

- Insert the rod with the blunt tip first to reduce soft tissue or implant damage
- Check that the rods can slide freely after assembly and are separated from each other

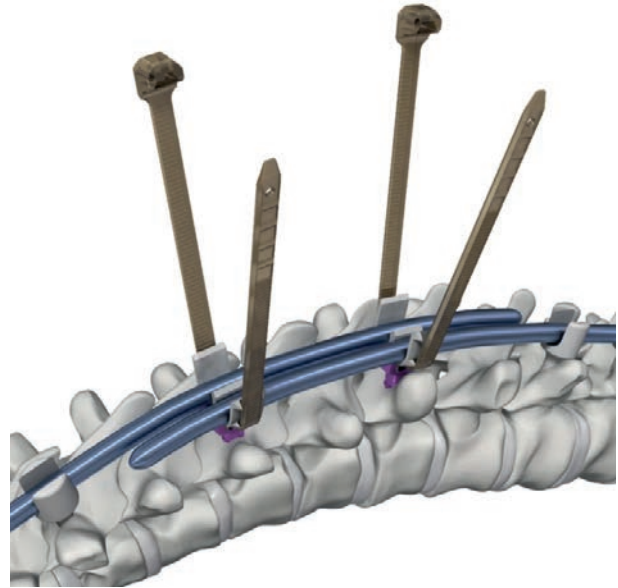

Notes:

- Ensure that overlapping rods are aligned to each other as parallel as possible in the gliding section to allow for controlled spinal guided growth
- Leave sufficient overlap at the gliding free ends. The overlap dictates the growth potential stored in the construct
- Do not reverse or over-bend the rods. Reverse or repeated bending produces internal stresses, which may become the focal point for early failure of the implant
- Mishandling of the rod causing surface damage can reduce the gliding potential of the construct
- Bend rods appropriately to allow insertion into the TROLLEY GVs as well as fixed spinal anchors and use Parallel Spacers to separate the rods
- Rod bending in the gliding zone (proximity of TROLLEY GVs) may compromise the gliding capabilities of the construct
- Minimize muscle contusion during rod insertion

2a Four-rod technique

Parallel Spacer (intended to be used in four-rod constructs only)

Instruments

03.641.006 Holding Forceps for Rib Hook Cap

Parallel Spacers can be used to guide and separate the rods from each other to prevent rod impingement.

Begin placement by clipping the Parallel Spacer onto one of the rods (1) using the Holding Forceps (03.641.006) and in a second step the Parallel Spacer will be pushed over the second rod (2). Use a TROLLEY Cable Tie to secure the Parallel Spacer. The Cable Tie Pusher in combination with the Holding Forceps for Cable Tie is used to close the Cable Tie (page 26) and the Cable Cutter to cut the Cable Tie (page 30).

Notes:

- Parallel Spacers are designed to reduce convergence of the two parallel rods. Direct contact of the rods could cause wear debris
- Therefore, it is recommended to implant Parallel Spacers at long intersections in four-rod constructs
- Be aware that Parallel Spacers might migrate during spinal growth. This does not affect functionality
- The use of Parallel Spacers is appropriate for four-rod constructs only where two parallel rods are placed on the same run of pedicle screws and interconnected to each other

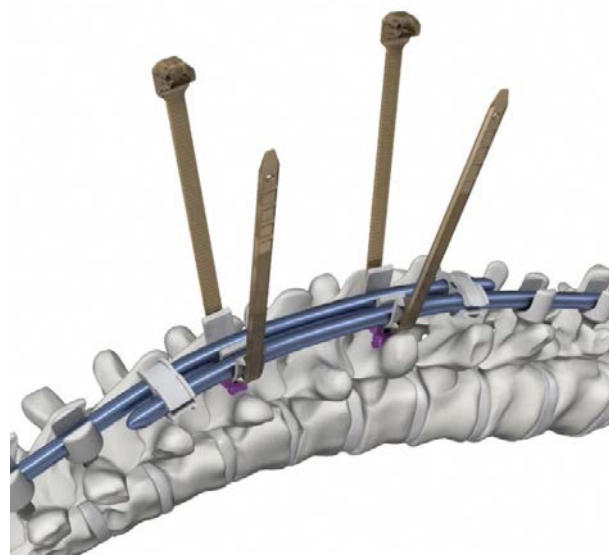
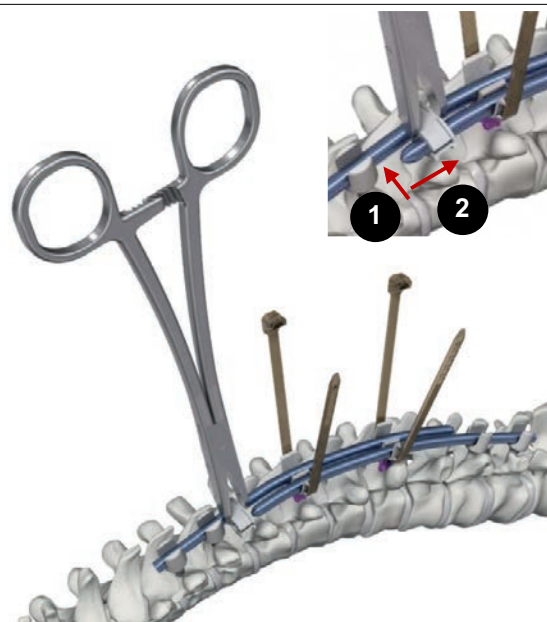

2a Four-rod technique

Insertion of Cable Tie for Parallel Spacer

Instruments

03.625.004	TROLLEY Holding Forceps for Cable Tie
------------	---------------------------------------

To secure the Parallel Spacer to the rods, an additional Cable Tie will be used.

It is recommended to bend the tip of the Cable Tie by hand (1) and thread it mediolateral through the TROLLEY GV bearing.

Grip the Cable Tie with the TROLLEY Holding Forceps for Cable Tie (03.625.004) and pull.

Note: Do not bend the Cable Tie at the hole location where you put the Holding Forceps as this may compromise the closing procedure

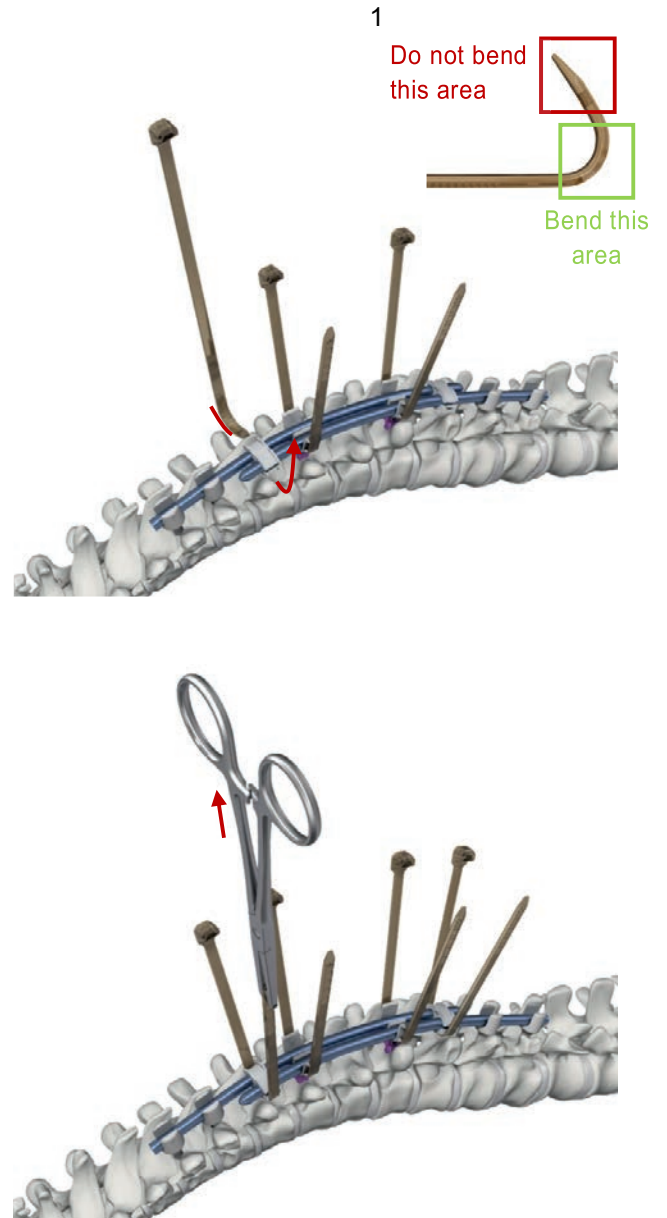

2b Two-rod technique

Contour and insert rods

Contour the polished rods according to your planned sagittal profile.

Insertion of the rods can be done either from the proximal or distal incision, tunneling the blunt tip towards the middle incision and engaging the TROLLEY GV bearing. Using the sagittal curve of the rods, they can be rotated partially facilitating the insertion of the rods and capturing the spinal implants.

The rods should be passed subfascially, without touching any bony surface.

Precautions:

- Insert the rod with the blunt tip first to reduce soft tissue or implant damage
- Check that the rods can slide freely after assembly

Notes:

- Leave sufficient overlap at the gliding free ends. The overlap dictates the growth potential stored in the construct
- Do not reverse or over-bend the rods. Reverse or repeated bending produces internal stresses, which may become the focal point for early failure of the implant
- Mishandling of the rods causing surface damage can reduce the gliding potential of the construct
- Bend rods appropriately to allow insertion into the TROLLEY GVs as well as fixed spinal anchors
- Rod bending in the gliding zone (proximity of TROLLEY GVs) may compromise the gliding capabilities of the construct
- Minimize muscle contusion during rod insertion

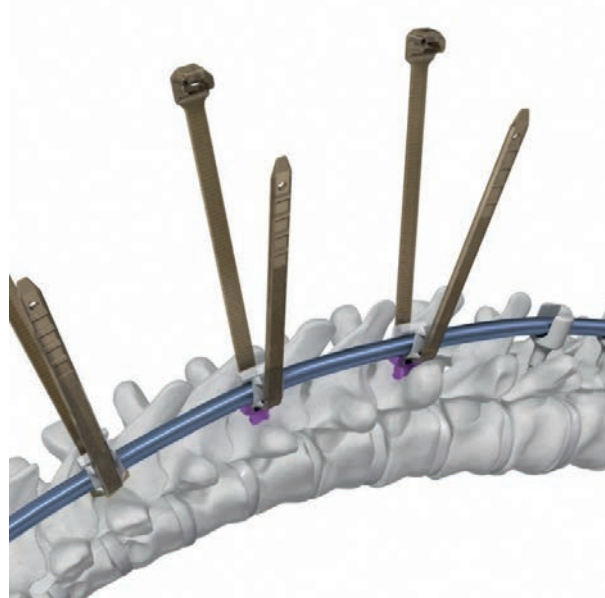

FINAL TIGHTENING

1

Close Cable Ties by hand

Close the TROLLEY Cable Ties over the rods by inserting the tip of the TROLLEY Cable Tie into the closure until the first teeth are engaged, approximately after ~30 mm. Continue pulling by hand in one swift motion making sure that the cable does not bind or kink.

Note: Cable Ties cannot be reopened again. If required, the Cable Tie needs to be cut and replaced (see chapter “Components Assembly”, page 35).

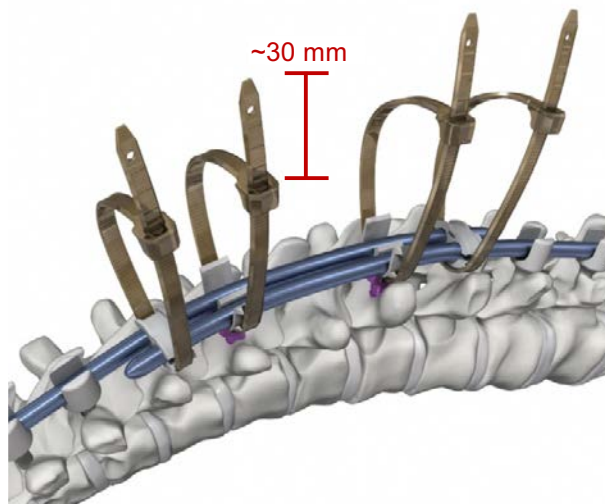

2

Final closure of TROLLEY Gliding Vehicles

Instruments

03.625.004	TROLLEY Holding Forceps for Cable Tie
03.625.006	TROLLEY Cable Tie Pusher
03.625.007	Double Rod Pusher, for Rods Ø 5.0/6.0 mm

Precaution: Do not use the Cable Tie for rod reduction. Use the Double Rod Pusher(s) to reduce rods.

Notes:

- When using the Double Rod Pusher(s), apply forces perpendicular to the rod only to avoid slippage of the Double Rod Pusher(s)
- Always use the Double Rod Pusher(s) as it establishes the recommended space between the two rods

The Cable Ties have to be sequentially closed, gradually capturing the rods. Deformity correction must be achieved by cantilevering the rods into parallel constructs and or undertaking rod derotation maneuvers with partially captured rods at three points of spinal fixation.

Once the correction has been achieved, position the Double Rod Pushers next to the TROLLEY GVs to push the rod into the bearing of the TROLLEY GVs. To close the Cable Ties use the Cable Tie Pusher and the Holding Forceps.

By levering the Holding Forceps on the Cable Tie Pusher and pulling on the Cable Tie, the Cable Tie can be closed. Proceed in a sequential fashion, final tightening all Cable Ties.

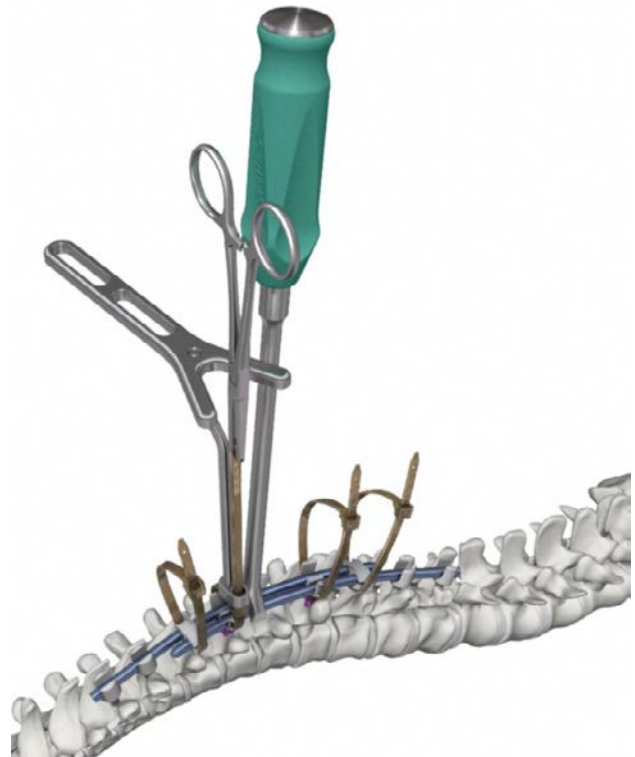
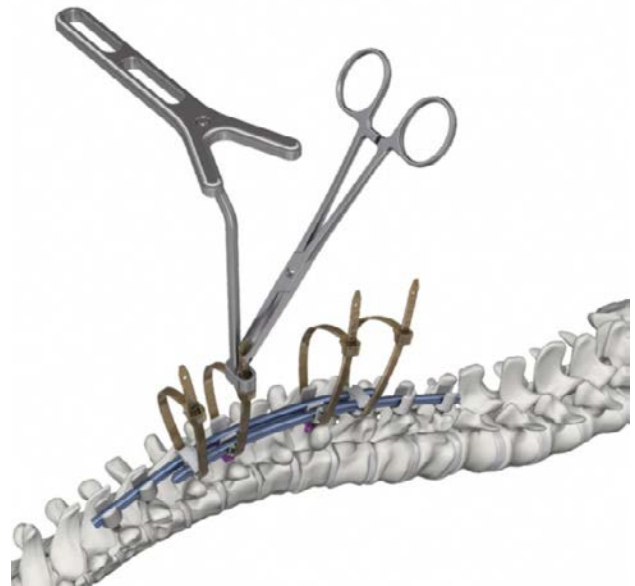

Do not attempt to correct the deformity by simply pulling on the Cable Tie as the Cable Tie is not indicated for such a maneuver.



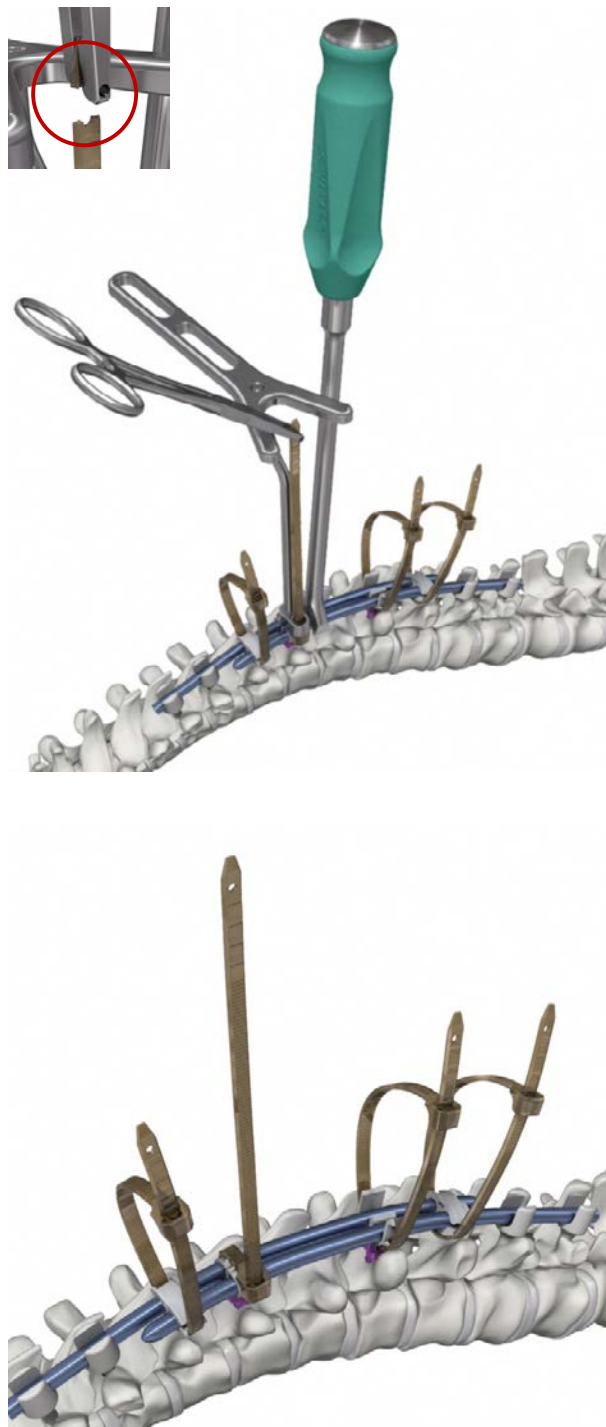

To prevent overtightening a fail-safe feature is incorporated in the design of the Cable Tie. When high tightening forces are applied, the tip will break off to limit forces on the lock. The broken off part will be secured in the forceps.

Note: Avoid scratching the rods with the Double Rod Pusher(s)







Note: Make sure that the rod(s) is (are) fully seated inside the TROLLEY GV bearing and that the bearing is firmly wrapped around the rod(s)

 **CORRECT**

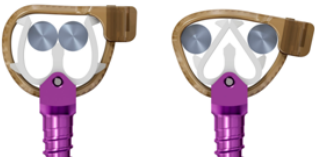
	Double	Single
Ø 5.0 mm		
Ø 5.0 / 6.0 mm		
Ø 6.0 mm		

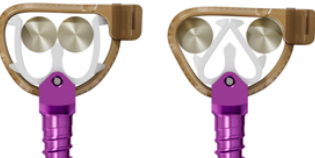
 **INCORRECT**

	Double	Single
Ø 5.0 mm		
Ø 5.0 / 6.0 mm		
Ø 6.0 mm		

3

Cutting off Cable Tie ends

Instruments

03.625.009	TROLLEY Cable Cutter for Cable Tie
------------	------------------------------------

Precaution: Before cutting the Cable Tie ends, ensure that the rods are fully seated inside the bearing of the TROLLEY GV (see previous page). Then, make sure to align the TROLLEY Cable Cutter for Cable Tie before cutting to avoid damage to the Cable Tie.

Before cutting the end of the Cable Tie, ensure that all Cable Ties and bearings are firmly wrapped around the rods.

Use the TROLLEY Cable Cutter for Cable Tie to cut off the overhanging ends of the Cable Tie. Make sure that the head of the Cable Cutter is flush with the closure (1) to minimize protrusion sharp edges.

Note: Maintain pressure on Cable Cutter handle when removing to prevent cut-off portion of Cable Tie from falling into the wound.

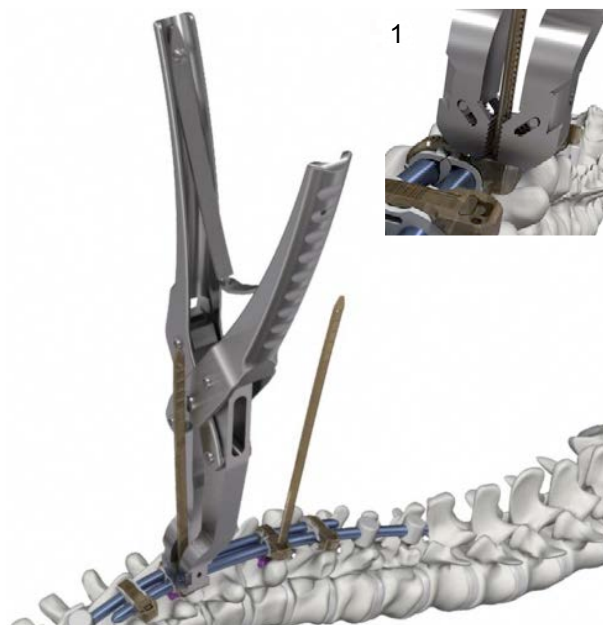

FINALIZE CONSTRUCT

1

Finalize construct

Finalize the TROLLEY construct using fixed spinal anchors and TROLLEY GV on the contra-lateral side. Final tighten fixed spinal anchors according to surgical technique guide of indicated systems.

Precaution: Use TROLLEY with indicated systems only (page 6)

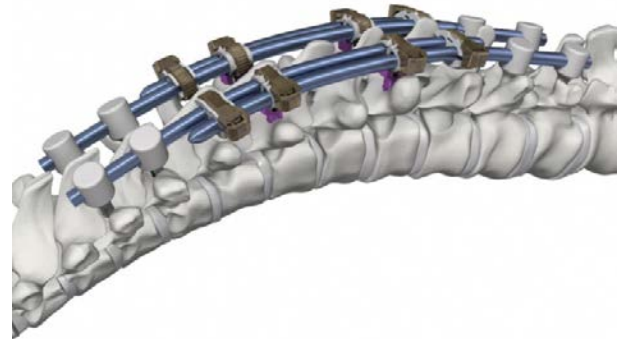

Fluoroscopic imaging (AP and lateral X-rays) may be crucial to control final construct positioning and achieved correction.

The Cable Tie includes a radiopaque marker pin for enhanced visualization indicating the position of the lock.

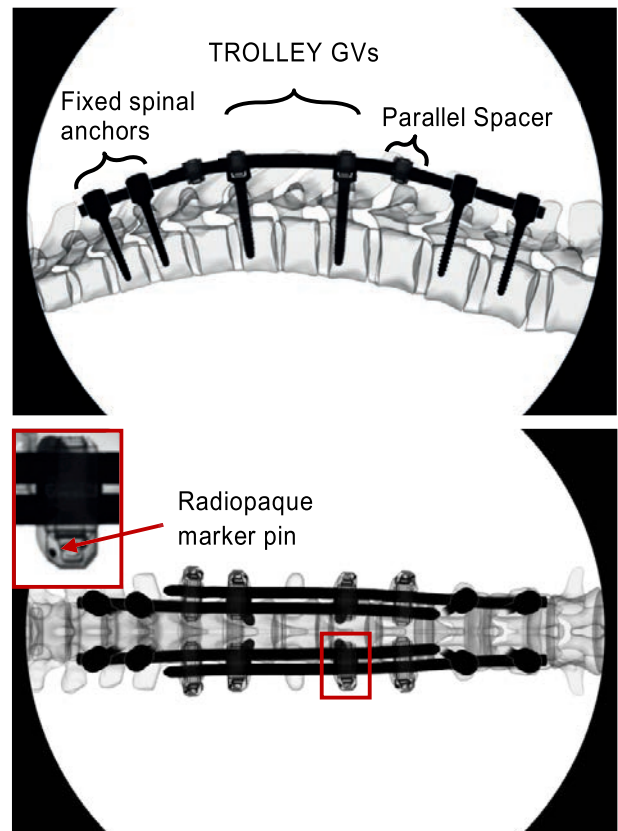

CONTINUUM OF CARE

1

Replacement of rod(s)

Patients who have outgrown their TROLLEY constructs, (= less than 2 TROLLEY GVs are connected per rod end) need a replacement of their rod(s) with longer one(s) to allow further growth of the spine:

Please perform the following steps below:

1. Cut open all Cable Ties by following the steps described in chapter "Removal of Trolley Gliding Vehicle" (page 36)
2. Follow the steps described in chapter "Components Assembly" (page 34) to insert new Cable Ties into the TROLLEY GVs
3. For the rod insertion procedure please perform the steps described in the chapter "Rod Insertion" (page 20)
4. Perform the final tightening procedure described in the chapter "Final Tightening" (page 26)
5. Finalize the construct by following the steps described in the chapter "Finalize Construct" (page 31)

ADDITIONAL IMPLANTS FOR STABILIZATION

1

Use of transverse connectors

Precaution: Do not use transverse connectors in the gliding zone as it will negatively affect the construct's ability to support growth.

For additional rotational stability transverse connectors can be mounted depending on the construct type chosen, either cranially and/or caudally or in the apex. The transverse connectors need to be placed between a pair of fixed spinal anchors. Choose the appropriate transverse connector with respect to the implanted rod diameter.

For \varnothing 5.0 mm rods, transverse connectors from the USS Small Stature/Pediatric sets can be used.

For \varnothing 6.0 mm rods, transverse connectors from the URS or USS II sets can be used.

For instructions of use for the selected transverse connector please refer to the surgical technique of the corresponding system.

Note: Transverse connectors are to be taken from the fixed pedicle screw system used to anchor the construct. There are no specific transverse connectors provided with the TROLLEY set.

Following transverse connectors can be used from the USS Small Stature/Pediatric set:

497.871 –	Transverse Connector, low profile, for Rods
497.879	\varnothing 5.0 mm, Titanium Alloy (TAN), light blue



Following transverse connectors can be used from the URS or USS II sets:

497.791 –	Transverse Connector, low profile, for rods \varnothing 6 mm
497.799	

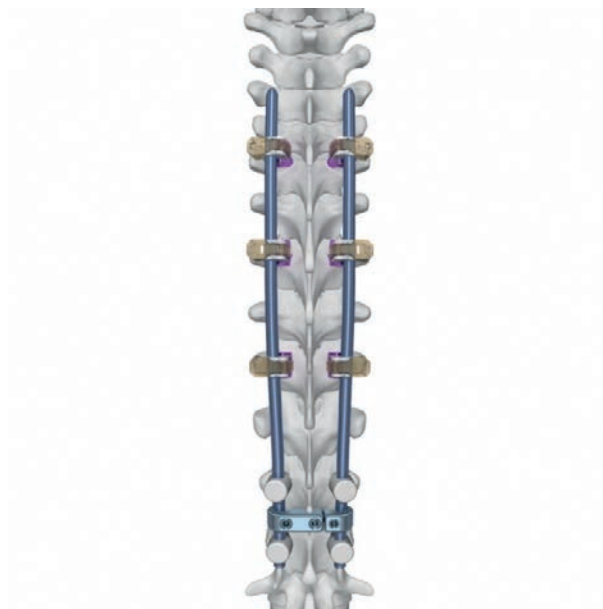

COMPONENTS ASSEMBLY

1 Insertion of Cable Tie

Instruments

03.625.004 TROLLEY Holding Forceps for Cable Tie

In cases where the Cable Tie is accidentally removed from the TROLLEY Gliding Vehicle or in case of revision surgery, the Cable Tie can be inserted manually.

It is recommended to bend the tip of the Cable Tie by hand (1) and push it through the TROLLEY GV bearing.

Then, the Cable Tie can be pulled up – either by hand or with the TROLLEY Holding Forceps for Cable Tie (03.625.004).

Notes:

- Make sure that the bearing of the TROLLEY GV is still intact before inserting a new Cable Tie. If the bearing is damaged, the TROLLEY GV needs to be replaced completely
- Do not bend the Cable Tie at the hole location where you put the Holding Forceps as this may compromise the closing procedure

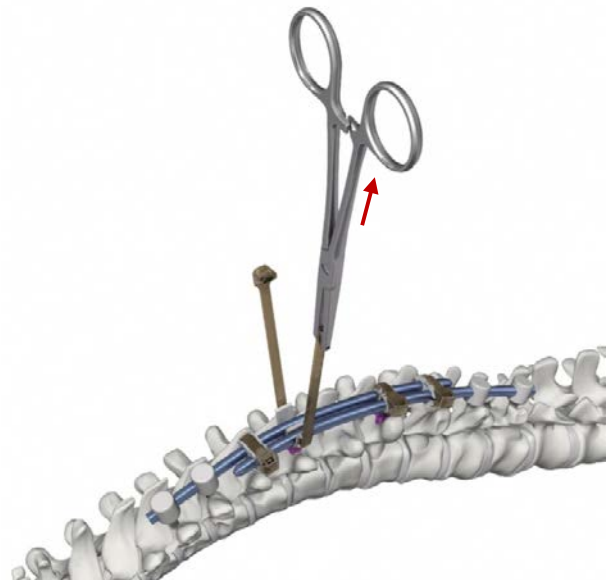
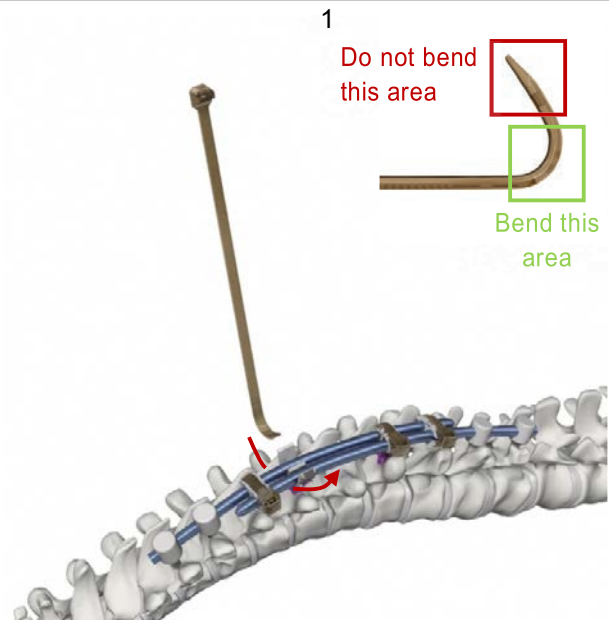

2

Reassembly of TROLLEY GV to TROLLEY applicator

Instruments

03.625.001 TROLLEY Screwdriver

In cases where the TROLLEY GV has been separated from the Screwdriver before the screw portion is inserted, the TROLLEY GV can be manually reassembled.

Match the Cable Tie head to the notch on the applicator and push the applicator into the TROLLEY GV (1).

Hold the Cable Tie ends toward the applicator (2) and slide the first ring on the holder down to the end of the applicator (3).

Slide the second ring over the lock of the Cable Tie (4).

The TROLLEY GV construct can now be reinserted into the TROLLEY Screwdriver (03.625.001), (page 16).

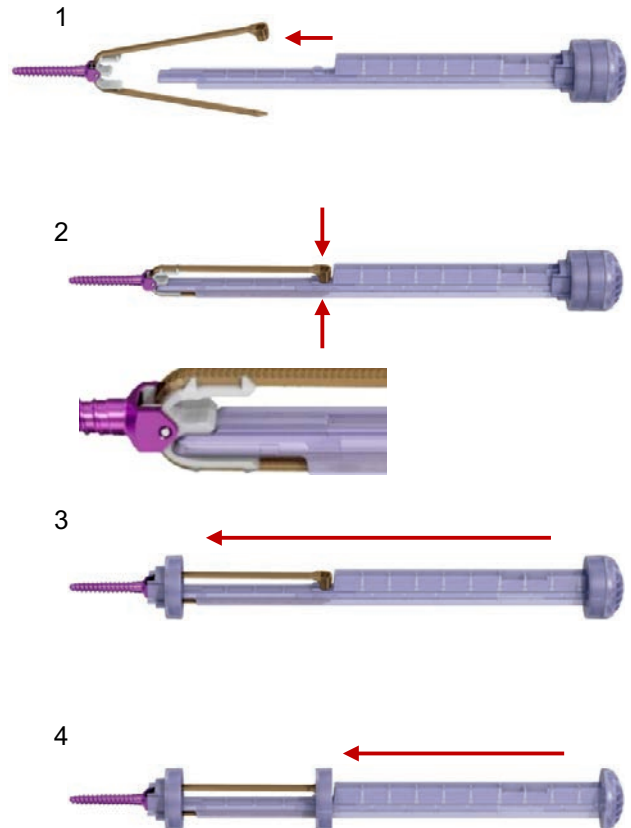

REMOVAL OF TROLLEY GLIDING VEHICLE

1

Removal of TROLLEY GV

Instruments

391.905	Cable Cutter, standard
---------	------------------------

03.625.005	TROLLEY Alignment Tool
------------	------------------------

Optional 03.625.009	Cable Cutter for Cable Tie
------------------------	----------------------------

For removal of the Cable Ties and the TROLLEY GVs, the Cable Tie has to be cut. It cannot be reused. For cutting of the Cable Tie use the Cable Cutter, standard (391.905). Alternatively, the Cable Cutter for Cable Tie (03.625.009) can be used.

Removal of the Cable Tie and rod(s) is required for complete removal of the TROLLEY GV. The TROLLEY Alignment Tool can be used as a screwdriver to remove the TROLLEY GV.

Note: In case of revision surgeries (e.g. rod needs to be replaced) cut all Cable Ties with the Cable Cutter, then replace the implanted rod with a longer one and follow the steps described in the chapter “Components Assembly” (page 34) to insert new Cable Ties.

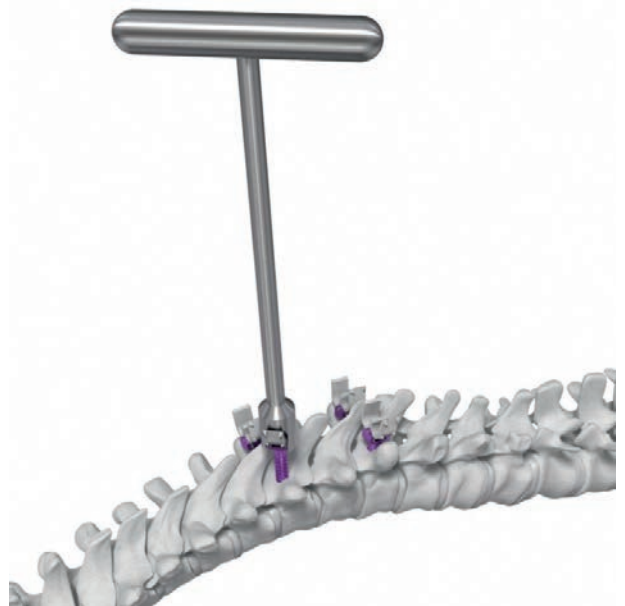
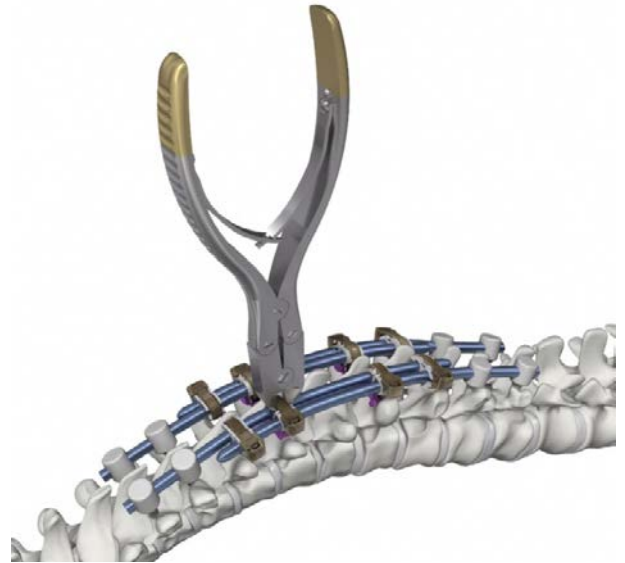

ASSEMBLY / DISASSEMBLY INSTRUCTIONS

ASSEMBLY INSTRUCTIONS

TROLLEY Screwdriver

03.625.001

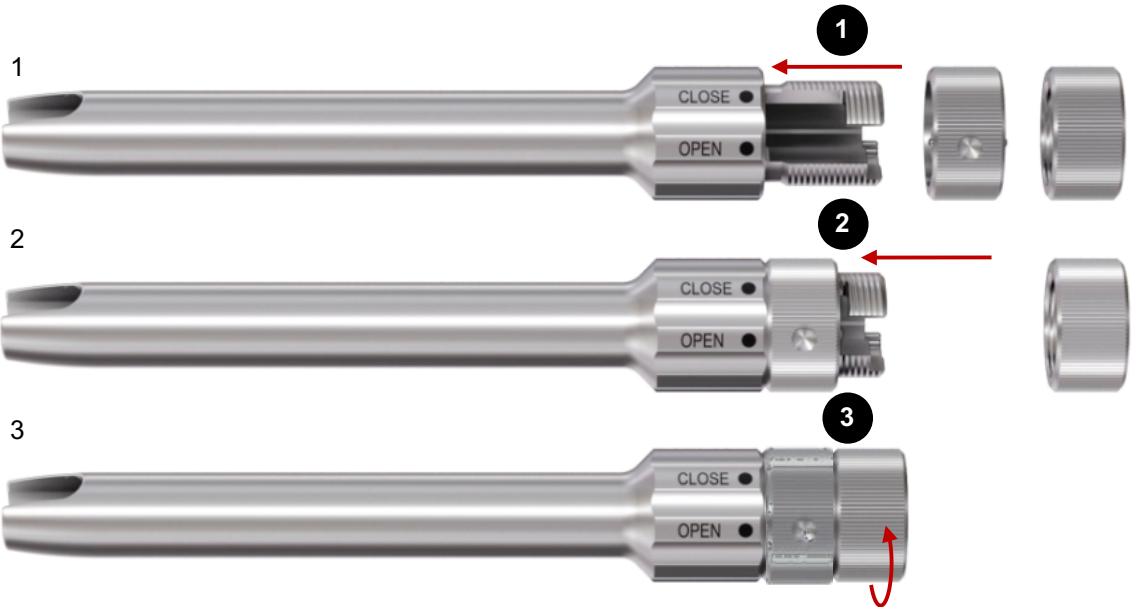

DISASSEMBLY INSTRUCTIONS

TROLLEY Screwdriver

03.625.001

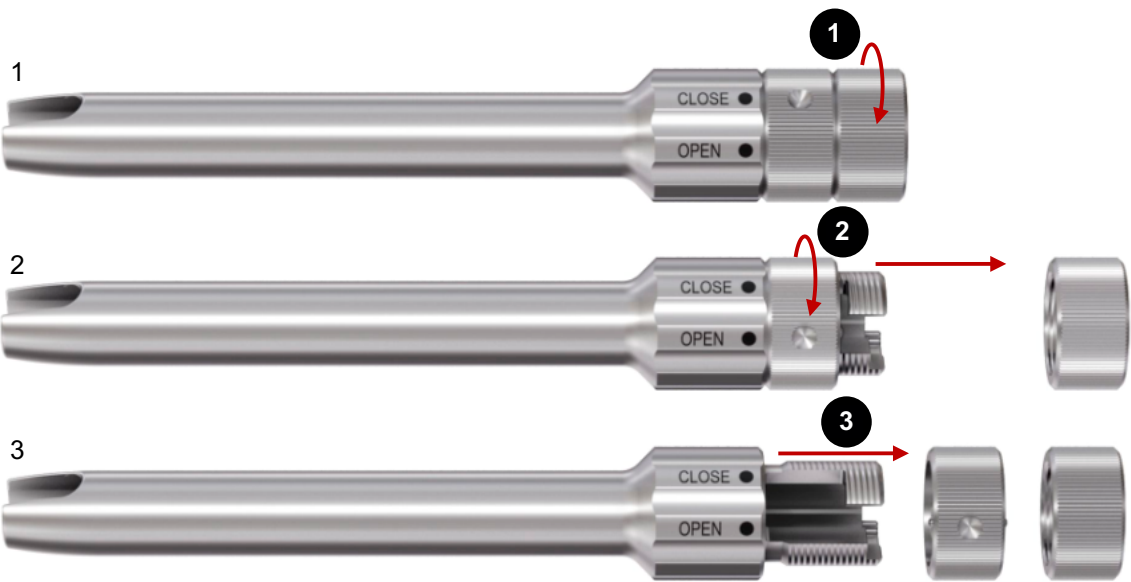

IMPLANTS

04.625.415S – 04.625.550S TROLLEY GV, Pedicle Screw, for two Rods, sterile



04.626.415S – 04.626.550S TROLLEY GV, Pedicle Screw, for one Rod, sterile



08.625.009S TROLLEY Parallel Spacer, sterile



08.625.012S TROLLEY Cable Tie, length 170 mm, sterile



04.625.053S – 04.625.055S TROLLEY Rod Ø 5.0 mm, with blunt tip, length 300/400/500 mm, polished, Titanium Alloy (TAN), sterile





04.625.063S – 04.625.065S TROLLEY Rod Ø 6.0 mm, with blunt tip, length 300/400/500 mm, polished, Titanium Alloy (TAN), sterile



Description	Lengths	for two Rods	for one Rod
TROLLEY GV, Pedicle Screw Ø 4.0 mm, length 15 mm, sterile	15 mm	04.625.415S	04.626.415S
TROLLEY GV, Pedicle Screw Ø 4.0 mm, length 20 mm, sterile	20 mm	04.625.420S	04.626.420S
TROLLEY GV, Pedicle Screw Ø 4.0 mm, length 25 mm, sterile	25 mm	04.625.425S	04.626.425S
TROLLEY GV, Pedicle Screw Ø 4.0 mm, length 30 mm, sterile	30 mm	04.625.430S	04.626.430S
TROLLEY GV, Pedicle Screw Ø 4.0 mm, length 35 mm, sterile	35 mm	04.625.435S	04.626.435S
TROLLEY GV, Pedicle Screw Ø 4.0 mm, length 40 mm, sterile	40 mm	04.625.440S	04.626.440S
TROLLEY GV, Pedicle Screw Ø 5.0 mm, length 20 mm, sterile	20 mm	04.625.520S	04.626.520S
TROLLEY GV, Pedicle Screw Ø 5.0 mm, length 25 mm, sterile	25 mm	04.625.525S	04.626.525S
TROLLEY GV, Pedicle Screw Ø 5.0 mm, length 30 mm, sterile	30 mm	04.625.530S	04.626.530S
TROLLEY GV, Pedicle Screw Ø 5.0 mm, length 35 mm, sterile	35 mm	04.625.535S	04.626.535S
TROLLEY GV, Pedicle Screw Ø 5.0 mm, length 40 mm, sterile	40 mm	04.625.540S	04.626.540S
TROLLEY GV, Pedicle Screw Ø 5.0 mm, length 45 mm, sterile	45 mm	04.625.545S	04.626.545S

TROLLEY GV, Pedicle Screw Ø 6.0 mm, length 20 mm, sterile	20 mm	04.625.620S	04.626.620S
TROLLEY GV, Pedicle Screw Ø 6.0 mm, length 25 mm, sterile	25 mm	04.625.625S	04.626.625S
TROLLEY GV, Pedicle Screw Ø 6.0 mm, length 30 mm, sterile	30 mm	04.625.630S	04.626.630S
TROLLEY GV, Pedicle Screw Ø 6.0 mm, length 35 mm, sterile	35 mm	04.625.635S	04.626.635S
TROLLEY GV, Pedicle Screw Ø 6.0 mm, length 40 mm, sterile	40 mm	04.625.640S	04.626.640S
TROLLEY GV, Pedicle Screw Ø 6.0 mm, length 45 mm, sterile	45 mm	04.625.645S	04.626.645S
TROLLEY GV, Pedicle Screw Ø 6.0 mm, length 50 mm, sterile	50 mm	04.625.650S	04.626.650S

INSTRUMENTS

03.625.001	TROLLEY Screwdriver	
03.625.004	TROLLEY Holding Forceps for Cable Tie	
03.625.005	TROLLEY Alignment Tool	
03.625.006	TROLLEY Cable Tie Pusher	
03.625.007	Double Rod Pusher, for Rods Ø 5.0/6.0 mm	
03.625.009	TROLLEY Cable Cutter for Cable Tie	
03.641.006	Holding Forceps for Rib Hook Cap	
391.905	Cable Cutter, standard	

TROLLEY SET LIST

Modular tray

68.625.001 Module for TROLLEY Instruments

Instruments

03.625.001 TROLLEY Screwdriver

03.625.004 TROLLEY Holding Forceps for Cable Tie

03.625.005 TROLLEY Alignment Tool

03.625.006 TROLLEY Cable Tie Pusher

03.625.007 Double Rod Pusher, for Rods
Ø 5.0/6.0 mm

03.625.009 TROLLEY Cable Cutter for Cable Tie

03.641.006 Holding Forceps for Rib Hook Cap

391.905 Cable Cutter, standard

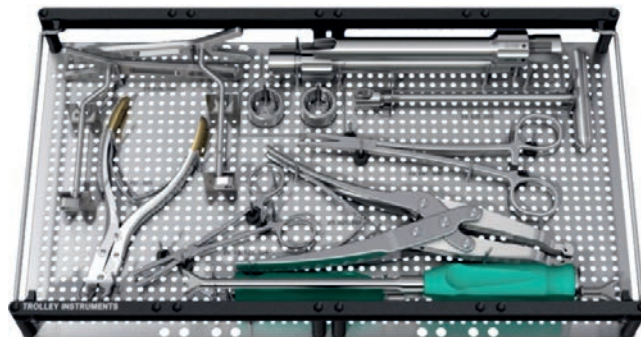

Lid for modular tray

68.001.103 Lid for Modular Tray, Next Generation,
size 1/1





Synthes GmbH
Eimattstrasse 3
4436 Oberdorf
Switzerland
Tel: +41 61 965 61 11
Fax: +41 61 965 66 00
www.depuySynthes.com

Not all products are currently available in all markets.

This publication is not intended for distribution in the USA.

All surgical techniques are available as PDF files at
www.depuySynthes.com/ifu

