

FORZA[®] XP
EXPANDABLE SPACER SYSTEM

Operative Technique

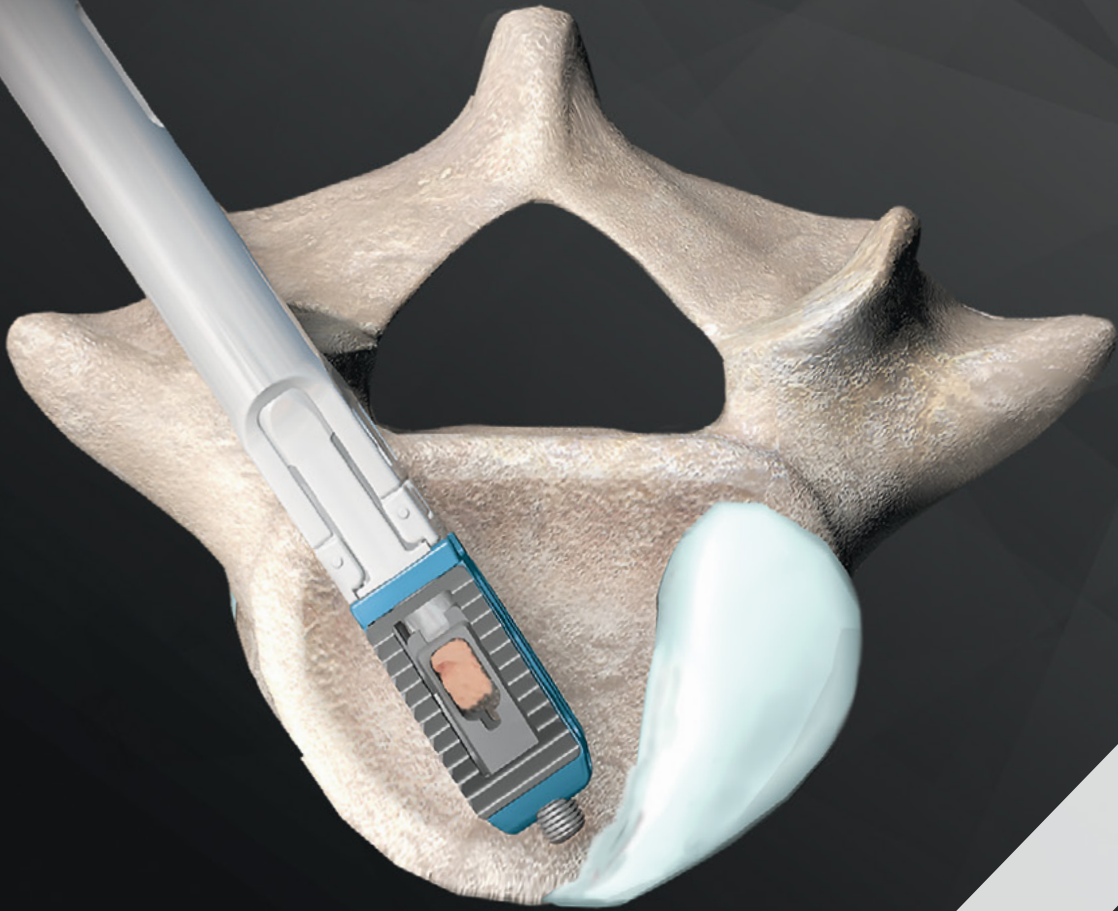

Table of Contents

1	Introduction
2	Operative Technique
11	Implants and Instruments
15	Implant Dimensions
17	Graft Volume Charts
18	Parts Numbers

The surgical technique shown is for illustrative purposes only. The technique(s) actually employed in each case will always depend upon the medical judgment of the surgeon exercised before and during surgery as to the best mode of treatment for each patient. Please see the Instructions For Use for the complete list of indications, warnings, precautions, and other important medical information.

INTRODUCTION

The FORZA® XP Expandable Spacer System offers titanium alloy expandable interbodies for Posterior Lumbar Interbody Fusion (PLIF) and Transforaminal Lumbar Interbody Fusion (TLIF) procedures. After insertion into the disc space, the interbodies can be continuously expanded (up to 3mm) to fit the patient anatomy.

Implant Features

- Minimum start height of 6.5mm
- Up to 3mm of continuous expansion
- No additional locking step once desired expansion height is achieved
- Ability to pack bone graft window after expansion
- Anatomical endplate design (excluding 6.5mm heights)
- Large graft window

Implant Specifications

- Implant Starting Heights: 6.5mm, 8.5mm, 10.5mm, and 12.5mm (optional)
- Implant Width: 10mm
- Implant Lengths: 24mm and 28mm
- Lordotic Profiles: non-lordotic, lordotic, and hyperlordotic



Non-Lordotic



Lordotic



Hyperlordotic

1. DISCECTOMY

Remove the disc with either an open or an MIS procedure using **Pituitary Rongeurs (89-0650 through 89-0653)** and **Curettes (89-0341 through 89-0391)** such as those provided in the FORZA Discectomy Case (89-0031) with minimal or no nerve root retraction. Both Cup and Ring Curettes are provided in the FORZA Discectomy Case. FORZA Ring Curettes are designed for linear scraping and not for rotating while in the intervertebral body space (**Fig. 1a & 1b**).

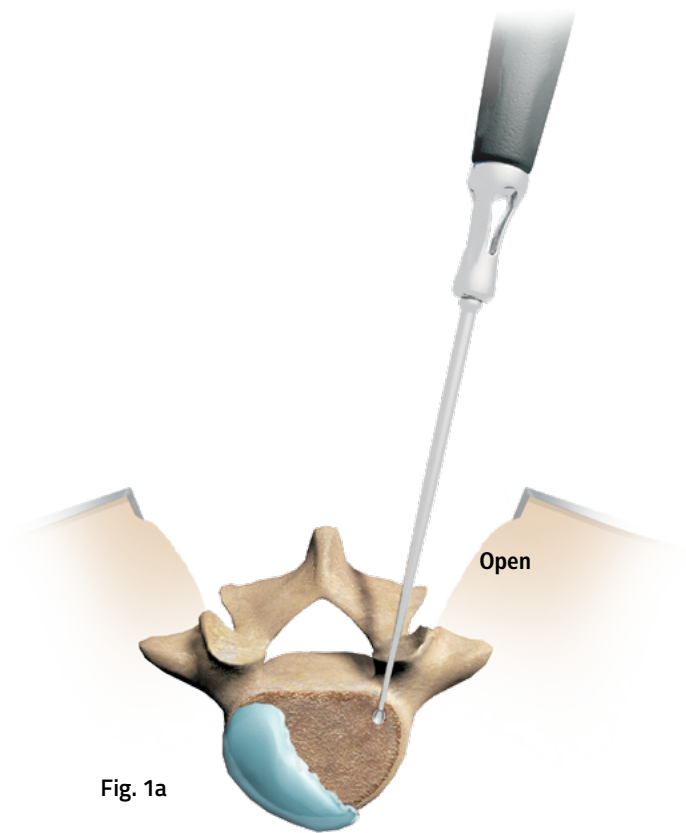

If there is significant disc space collapse, completion of the discectomy may not be possible until distraction of the disc space takes place.

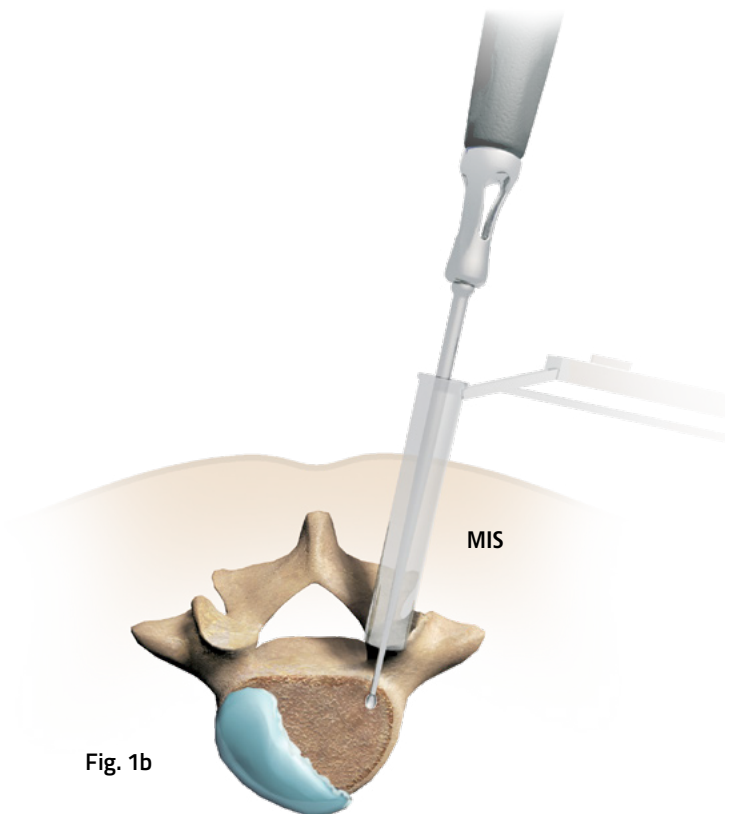

2. DISC SPACE PREPARATION

Distract the disc space sequentially using distractors such as the **Paddle Distractors (89-0250 through 89-0260)** provided in the FORZA Discectomy Case. The heights are clearly indicated on the instruments and the shafts are color coded.

Note: Although color coding may be a useful tool, colors may vary. It is therefore imperative to confirm the size with the numbers on the instrument.

Heights	Colors
6mm	Bronze
7mm	Blue
8mm	Green
9mm	Gold
10mm	Dark Blue
11mm	Magenta
12mm	Seafoam
13mm	Gray
14mm	Teal
15mm	Purple
16mm	Copper or Pink

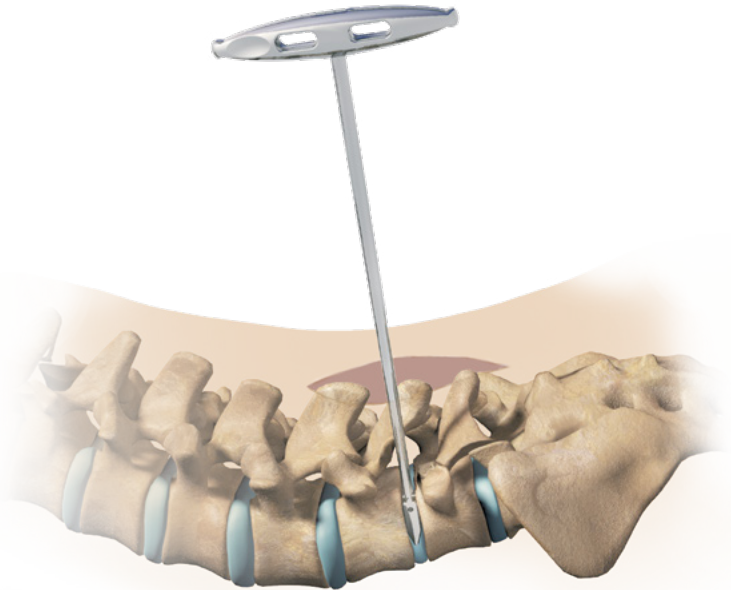
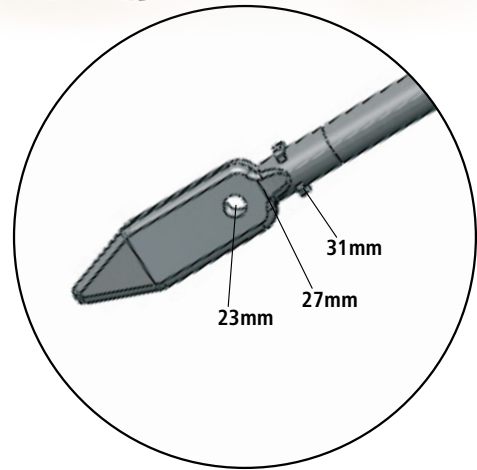

Fig. 2



There are three indicators on the FORZA distractors: a circle punch (23mm), the end of the body (27mm), and the small protrusions on the neck (31mm). Each of these length indicators are visible with fluoroscopy. The FORZA XP spacers are available in 24mm and 28mm lengths and will be 1mm longer than the closest indicator on the distractor (23mm and 27mm). The 31mm indicator does not correspond with a FORZA XP spacer length.

Insert the Paddle Distractor with the sides touching the endplates and turn to distract. If necessary, repeat sequentially with additional sizes until desired disc space height and foraminal size is obtained.

(Fig. 2)

		FORZA XP Spacers			
		6.5mm	8.5mm	10.5mm	12.5mm
FORZA Discectomy Heights	6mm				
	7mm	X			
	8mm	X			
	9mm	X	X		
	10mm		X		
	11mm		X	X	
	12mm			X	
	13mm			X	X
	14mm				X
	15mm				X
16mm					

3. ENDPLATE SPACE PREPARATION

Rotating Cutters (89-0406 through 89-0416) are provided in sequential heights to remove any additional disc and to prepare the endplates.

(Fig. 3) The Rotating Cutters in the FORZA Discectomy Case are designed for safety with a blunt tip and cutting sides.

The color coded rotating sleeve is designed for use with two hands for a smooth cutting motion. The lengths, 23mm, 27mm, and 31mm, are indicated on the Rotating Cutters with numbers and bars, and small holes that can be seen by lateral fluoroscopy when the instrument is directly straight such as in a PLIF position. The heights are clearly indicated on the instruments and the rotating sleeves are color coded.

The FORZA XP spacers are available in 24mm and 28mm lengths and will be 1mm longer than the closest indicator.

As with the FORZA Distractors, colors are variable, therefore it is imperative to confirm the size with the numbers on the instrument. See previous page for the height/color chart. Choices of **Rasps (89-0300 through 89-0303)**, Curettes, and other additional instruments are provided in the FORZA Discectomy Case for disc removal and Endplate Preparation.

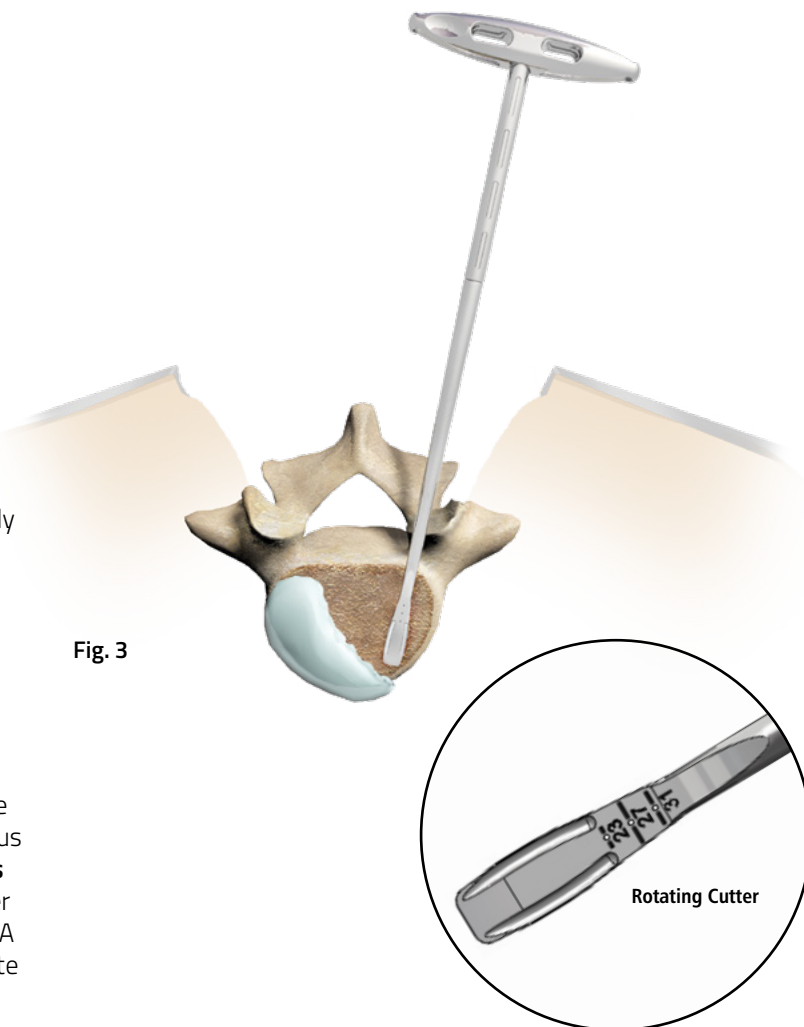

Fig. 3

4. TRIAL SIZING

FORZA XP Trials (28-1006, 28-1008, 28-1010, 28-1012 - optional) are 10mm wide and 24mm long with length indicators that are visible with fluoroscopy. The notch on the shaft indicates 28mm. Trial heights correspond with the starting height of the FORZA XP spacers, 6.5mm, 8.5mm, 10.5mm and 12.5mm (optional).

Insert the FORZA XP Trials into the disc space to determine the correct spacer size. Use A/P and lateral fluoroscopy for placement and trajectory. **(Fig. 4).**

Once the desired FORZA XP Trial size is determined, match the size with the appropriate FORZA XP spacer.



Fig. 4

A **Slap Hammer (28-1027)** is provided in the FORZA XP instrument set for assisting with pulling the FORZA XP Trial out of the disc space. Holding the tip of the Trial distally, screw the Slap Hammer in to the Trial handle (**Fig. 5a and 5b**).

Note: Screw the Slap Hammer into the Trial until completely seated at the flange.

Note: Prior to advancing the male thread, turning it a quarter turn counterclockwise helps start the thread and avoids cross threading.



Fig. 5a



Fig. 5b

5. IMPLANT ATTACHMENT

Prior to inserting the spacer into the disc space, place autograft or allograft comprised of cancellous and/or corticocancellous bone graft in the anterior disc space. Place additional graft contralaterally to the spacer once it is inserted.

To reduce potential for graft tissue blocking the expansion drive in the FORZA XP spacer, examine the cannula of the Implant Inserter and completely remove residual graft material prior to attaching the implant.

Attach the appropriately sized FORZA XP spacer to the **Implant Inserter (28-1101)** by aligning the spacer between the clamps and turning the knob clockwise until the spacer is firmly attached (**Fig. 6**).

Note: Make sure to keep the spacer seated against the inserter while initiating knob tightening. Tug on spacer to check secure fitting.

6. STABILIZER DRIVER ASSEMBLY

Stabilizer Drivers (28-1102 and 28-1103) are provided for implant insertion and allow for greater rigidity while directing the implant to the desired position in the disc space. Stabilizer Drivers correspond with the lengths of the FORZA XP spacers, 24mm (silver knob) and 28mm (gold knob).

Select the appropriate Stabilizer Driver that matches the length of the FORZA XP spacer attached to the Implant Inserter. Advance the distal tip of the Stabilizer Driver into the proximal cannula of the Implant Driver until it stops (**Fig. 7a**). Rotate the Impaction Cap clockwise until it is fully threaded to the Implant Inserter (**Fig. 7b**) being careful not to rotate the Inner Knob simultaneously which could lead to partial expansion of the FORZA XP spacer prior to insertion.

Note: The Inner Knob located within the Impaction Cap may need minor rotation to fully seat within the FORZA XP spacer.

Note: The Inner Knob should be fully rotated counterclockwise until it stops prior to insertion. This ensures that the FORZA XP spacer is fully closed prior to insertion. Otherwise, it may result in partial expansion of the spacer that would make insertion difficult or lead to implant damage.

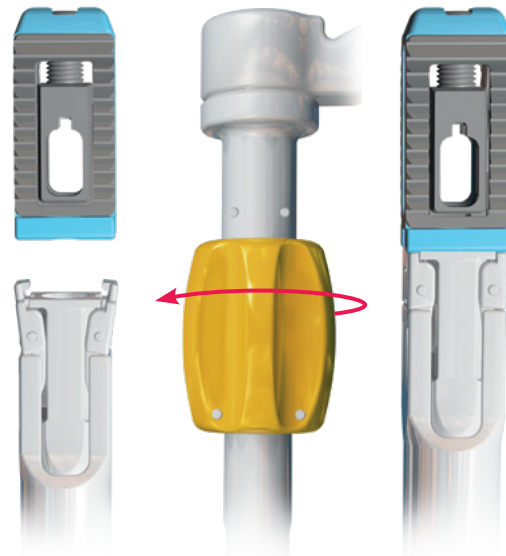

Fig. 6

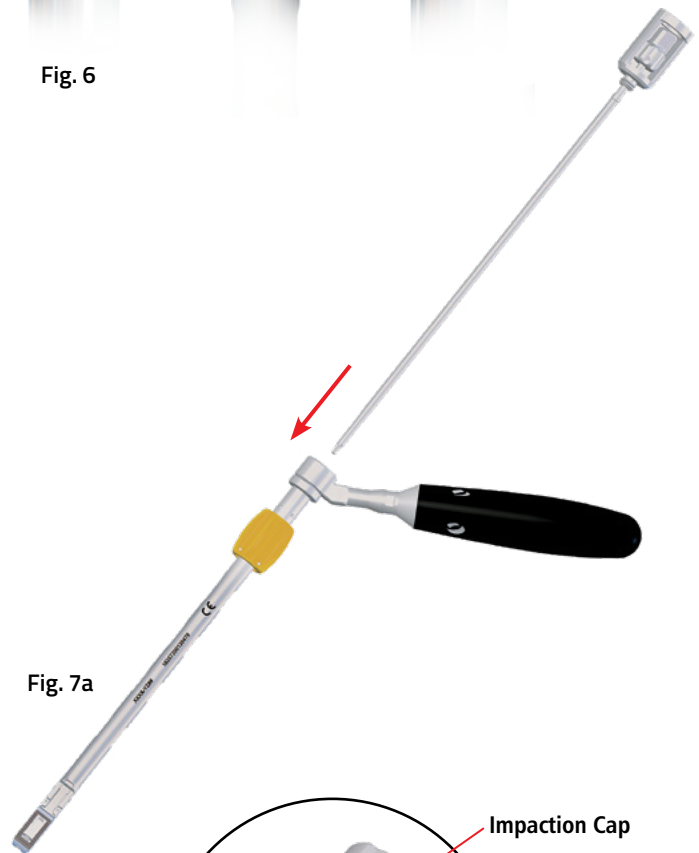

Fig. 7a

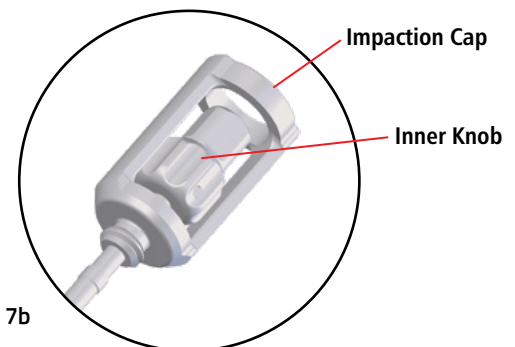

Fig. 7b

Note: Prior to advancing the male thread, turning it a quarter turn counterclockwise helps in alignment and to avoid cross threading.

Note: Insertion and steering of the spacer into the disc space without the use of the Stabilizer Driver could result in loss of engagement between the Implant Inserter and the spacer leading to a delay in surgery.

Note: The Stabilizer Driver must be assembled to the Implant Inserter prior to insertion to prevent graft material or tissue from blocking the expansion drive of the FORZA XP spacer.

7. IMPLANT INSERTION

While attached to the assembled Inserter, Insert the FORZA XP spacer into the prepared disc space (**Fig. 7c**) and place it to its desired position.

Caution: It is recommended to insert the spacer under fluoroscopic guidance to ensure proper positioning.

Caution: Always insert the FORZA XP spacer in fully closed (non-expanded) state to avoid potential damage to the spacer.

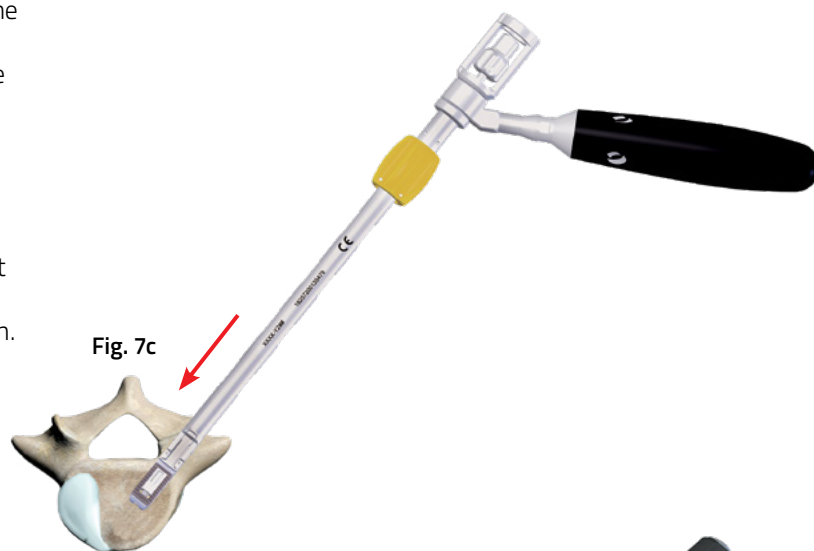

8. IMPLANT EXPANSION

The FORZA XP spacer must be expanded once it is placed to its desired position. Attach the **Driver Adapter (28-1104)** to the **Axial Torque Limiting Handle (28-1021 or 28-1031)** by pulling back the handle collar and inserting it into the adapter connection (**Fig. 8a**). Pull the adapter to ensure a secure connection. Insert the assembled instrument within the impaction cap of the Stabilizer Driver so that it is seated around the inner silver knob.

Important: Ensure the correct length Stabilizer Driver is assembled or implant expansion cannot be properly performed.



8. IMPLANT EXPANSION (Cont.)

Once engaged, the FORZA XP spacer can be expanded by rotating the Torque Limiting Handle clockwise until the desired amount of expansion is achieved. (Fig. 8b) The Torque Limiting Handle will limit out at the corresponding implant(s) maximum allowable amount of expansion or 18 in-lbs if the maximum amount of expansion cannot be achieved based on patient anatomy. There is no secondary locking step required for implant expansion. Implant Expansion can be reduced by rotating the Torque Limiting Handle counterclockwise until the desired height is achieved.

Warning: FORZA XP spacers must be expanded upon insertion to reduce the risk of expulsion or migration post-operatively.

Note: The laser marked line on the Driver Adapter is a visual indicator to facilitate rotation count.

Note: Reference Implant Dimensions for corresponding implant(s) maximum allowable amount of expansion.

Note: It is recommended to check final placement of the FORZA XP spacer with A/P and lateral fluoroscopy.

Caution: If re-positioning is necessary, the FORZA XP spacer must be reduced to the fully closed (non-expanded) state to avoid potential damage to the spacer.



Fig. 8b

9. GRAFT PACKING

Once the FORZA XP spacer is in situ and has been expanded, autograft and/or allograft comprised of cancellous and/or corticocancellous bone graft must be added through the posterior opening of the implant into the graft window. Bone graft is delivered through the Implant Inserter cannula by way a Funnel (28-1023) (Fig. 9a)

To add bone graft, rotate the impaction cap of the Stabilizer Driver counterclockwise until it is no longer threaded and can be removed proximally from the Implant Inserter.

Note: Remove the Stabilizer Driver with care not to rotate the Inner Knob while unthreading the Impaction Cap from the Implant Inserter as it may result in reduced expansion/ lordosis or inadequate contact force at the endplates of the FORZA XP spacer.

Attach the Funnel by threading it to the proximal cannula of the Implant Inserter without overtightening the Funnel on the Implant Inserter or applying lateral forces on the Funnel while plunging.

Note: Prior to advancing the male thread, turning it a quarter turn counterclockwise helps in alignment and to avoid cross threading.

Warning: Do not place bone graft in the FORZA XP spacer prior to both final positioning and expansion of the implant. The bone graft will prevent the Stabilizer Driver from being able to seat into the implant expansion drive and will limit the FORZA XP spacer height from being reduced to its fully closed position.



Fig. 9a

9. GRAFT PACKING (Cont.)

Reference the Graft Volume Chart and place the appropriate amount of bone graft into the Funnel opening and use the **Funnel Plunger (28-1124)** to advance it through the inner cannula of the Implant Inserter (**Fig. 9b**).

The laser marked band near the handle of the Funnel Plunger indicates that the distal tip position of the Funnel Plunger is flush to the posterior opening of the FORZA XP spacer when the laser marked band is positioned at the base of the Funnel and still visible (**Fig. 9c**).

Note: The laser marked band should always be visible within the Funnel. Further insertion of the laser mark beyond the base on the Funnel is not recommended as it may result in potential dislodging of the FORZA XP spacer from the inserter.

Note: Observe the position of the laser marked band near the base of the funnel as graft material is packed into the FORZA XP spacer. Tactile feedback and the amount of resistance during packing should be considered to prevent overfilling. The FORZA XP spacer may be packed full prior to the laser marked band reaching the base of the funnel. Graft volumes vary by part number and the amount of expansion. Please refer to the Graft Volume Chart and use appropriate care not to overfill the window of the FORZA XP spacer.

Note: Use the Funnel Plunger with care to avoid altering the final position of the FORZA XP spacer. Re-positioning of the spacer may be difficult or not possible after the bone graft is placed into the spacer graft window.

Note: It is recommended to check final placement of the FORZA XP spacer with A/P and lateral fluoroscopy.

After the FORZA XP spacer has been adequately filled with bone graft, remove the Funnel Plunger from the Implant Inserter. Rotate the gold knob on the Implant Inserter counterclockwise until it no longer rotates and can detach from the FORZA XP spacer.

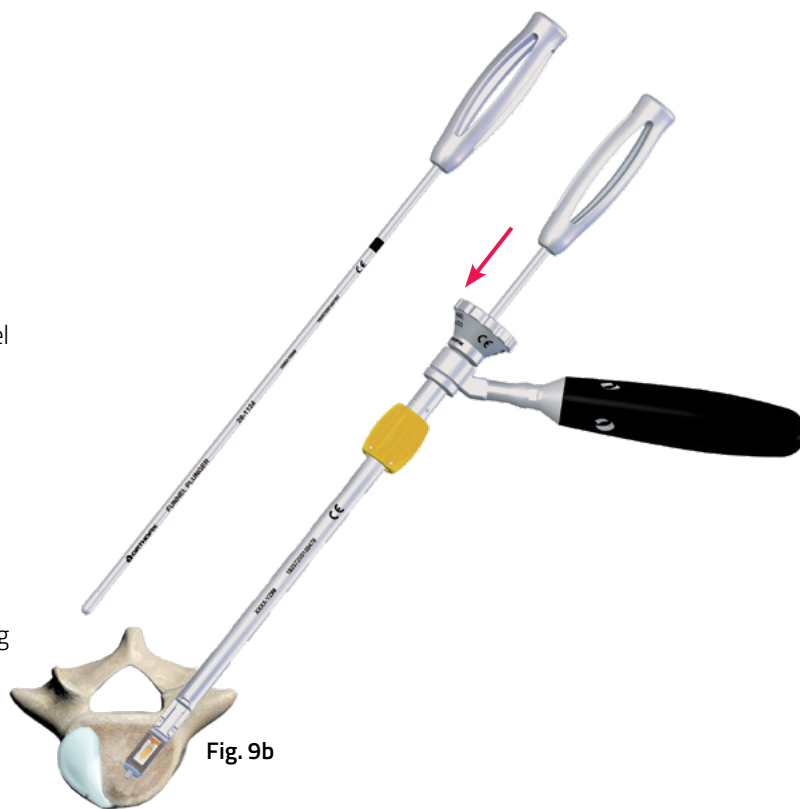

Fig. 9b

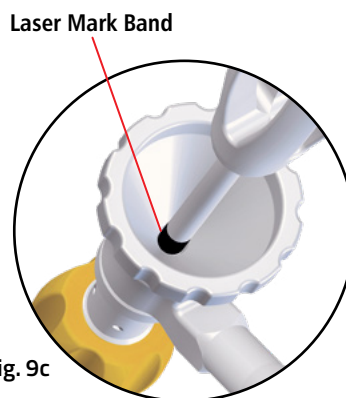

Fig. 9c

10. INTRAOPERATIVE REMOVAL PRIOR TO GRAFT PLACEMENT (If Necessary)

Follow these steps for removing the FORZA XP spacer with the removal tools.

1. Use fluoroscopy to determine exact spacer location.
2. Attach the **Implant Remover (28-1003)** to the spacer by screwing it into the spacer as shown in **(Fig 10a)**.
3. Use the **Implant Remover Driver (28-1004)** attached to the Torque Limiting Handle to reduce expansion of the FORZA XP spacer to its original height **(Fig. 10b)**.
4. Attach the Slap Hammer by screwing it to the Implant Remover. **(Fig. 10c)**
5. Pull up on the sleeve of the Slap Hammer to remove the spacer.

Note: Prior to advancing the male thread, turning it a quarter turn counterclockwise helps in alignment and to avoid cross threading.

11. POSTOPERATIVE REMOVAL (If Necessary)

Post-operative removal may be difficult as bone graft will prevent the Implant Remover Driver from being able to seat into the implant expansion drive and will limit the FORZA XP spacer height from being reduced to its fully closed position. Additional endplate preparation and distraction of the disc space may be necessary to allow for retrieval of the FORZA XP spacer.

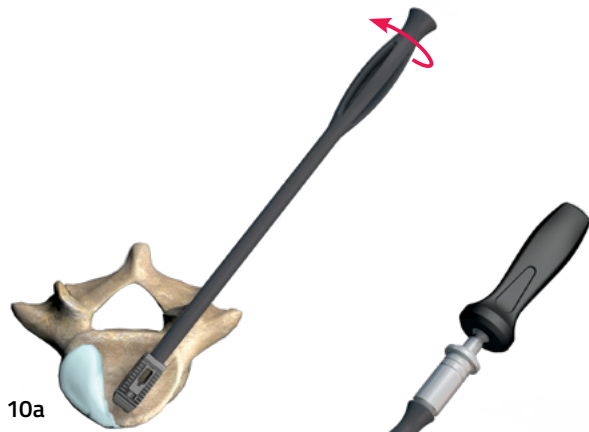

Fig. 10a

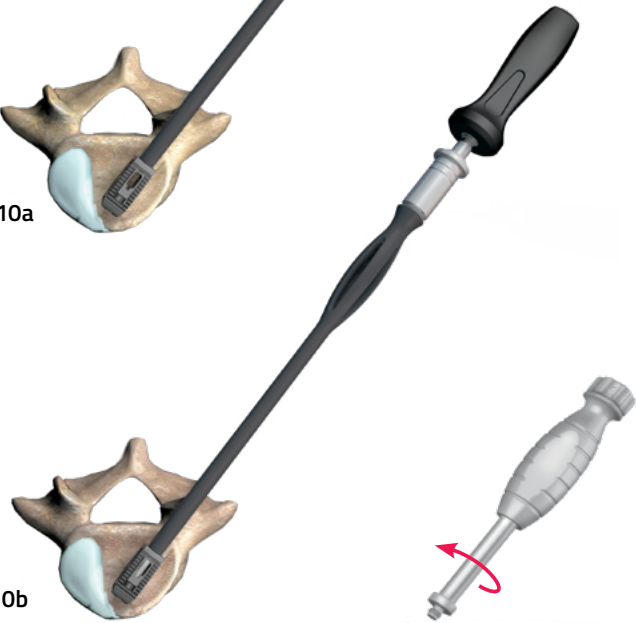

Fig. 10b





Fig. 10c

Implants





	Part #	Description	Qty
	Non-Lordotic		
	28-2140	6.5mm H x 10mm W x 24mm L	2
	28-2142	8.5mm H x 10mm W x 24mm L	3
	28-2144	10.5mm H x 10mm W x 24mm L	1
	28-2146	12.5mm H x 10mm W x 24mm L	Optional
	28-2180	6.5mm H x 10mm W x 28mm L	1
	28-2182	8.5mm H x 10mm W x 28mm L	1
	28-2184	10.5mm H x 10mm W x 28mm L	Optional
28-2186	12.5mm H x 10mm W x 28mm L	Optional	
	Lordotic		
	28-3140	6.5mm H x 10mm W x 24mm L	3
	28-3142	8.5mm H x 10mm W x 24mm L	3
	28-3144	10.5mm H x 10mm W x 24mm L	2
	28-3146	12.5mm H x 10mm W x 24mm L	Optional
	28-3180	6.5mm H x 10mm W x 28mm L	1
	28-3182	8.5mm H x 10mm W x 28mm L	2
	28-3184	10.5mm H x 10mm W x 28mm L	2
28-3186	12.5mm H x 10mm W x 28mm L	Optional	
	Hyperlordotic		
	28-4142	8.5mm H x 10mm W x 24mm L	2
	28-4144	10.5mm H x 10mm W x 24mm L	1
	28-4146	12.5mm H x 10mm W x 24mm L	Optional
	28-4182	8.5mm H x 10mm W x 28mm L	1
	28-4184	10.5mm H x 10mm W x 28mm L	1
28-4186	12.5mm H x 10mm W x 28mm L	Optional	

Note: Many optional implants are not stocked and have a minimum 12 week lead time.
12.5mm Heights are not standard in the set and are considered optional.





Instruments

	Part #	Description	Qty Set
	28-1101	Implant Inserter	2
	28-1003	Implant Remover	1
	28-1004	Implant Remover Driver	1
	28-1102	Stabilizer Driver, 24mm	2
	28-1103	Stabilizer Driver, 28mm	2
	28-1104	Driver Adapter	2

Instruments

Part #	Description	Qty Set
28-1006	6.5H X 10W Trial	1
		
28-1008	8.5H X 10W Trial	1
		
28-1010	10.5H X 10W Trial	1
		
28-1012	12.5H X 10W Trial	Optional
		

Instruments

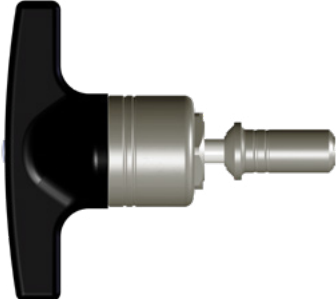
	Part #	Description	Qty Set
	28-1023	Funnel	1
	28-1124	Funnel Plunger	1
	28-1027	Slap Hammer	1
	28-1021 or 28-1031	Axial Torque Limiting Handle	1
	28-1132	Torque Limiting Handle (T-Handle)	Optional

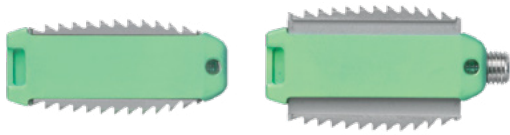

Non-Lordotic

Size	Part Number	Width (mm)	Length (mm)	Starting Height (mm)	Expanded Height (mm)	Expanded Anterior Height (mm)	Expanded Posterior Height (mm)	Max Lordosis	Expansion Drive (mm)
6.5mm H x 10mm W x 24mm L	28-2140	10.5	24.5	6.8	10.1	10.1	10.1	0°	2.6
8.5mm H x 10mm W x 24mm L	28-2142	10.5	24.5	8.6	11.9	10.5	10.1	5°	2.6
10.5mm H x 10mm W x 24mm L	28-2144	10.5	24.5	10.6	13.9	12.5	12.1	5°	2.6
12.5mm H x 10mm W x 24mm L	28-2146	10.5	24.5	12.6	15.9	14.6	14.1	5°	2.6
6.5mm H x 10mm W x 28mm L	28-2180	10.5	28.0	6.8	10.1	10.1	10.1	0°	1.7
8.5mm H x 10mm W x 28mm L	28-2182	10.5	28.0	8.7	12.0	10.4	10.1	4°	1.7
10.5mm H x 10mm W x 28mm L	28-2184	10.5	28.0	10.7	14.0	12.4	12.0	4°	1.7
12.5mm H x 10mm W x 28mm L	28-2186	10.5	28.0	12.7	16.0	14.5	14.1	4°	1.7

For every rotation of the driver, the Non-Lordotic implants increase in height by approximately 0.6mm.

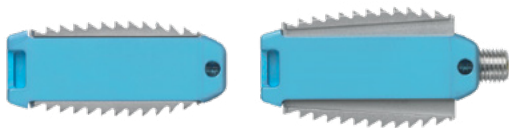

Lordotic

Size	Part Number	Width (mm)	Length (mm)	Starting Height (mm)	Expanded Height (mm)	Expanded Anterior Height (mm)	Expanded Posterior Height (mm)	Max Lordosis	Expansion Drive (mm)
6.5mm H x 10mm W x 24mm L	28-3140	10.5	24.5	6.8	10.3	10.3	8.3	7°	3.4
8.5mm H x 10mm W x 24mm L	28-3142	10.5	24.5	8.6	11.7	10.8	8.3	12°	3.4
10.5mm H x 10mm W x 24mm L	28-3144	10.5	24.5	10.6	13.6	12.8	10.2	12°	3.4
12.5mm H x 10mm W x 24mm L	28-3146	10.5	24.5	12.6	15.5	14.8	12.2	12°	3.4
6.5mm H x 10mm W x 28mm L	28-3180	10.5	28.0	6.8	10.5	10.5	8.1	7°	2.4
8.5mm H x 10mm W x 28mm L	28-3182	10.5	28.0	8.7	11.8	10.9	8.1	11°	2.4
10.5mm H x 10mm W x 28mm L	28-3184	10.5	28.0	10.7	13.8	12.9	10.1	11°	2.4
12.5mm H x 10mm W x 28mm L	28-3186	10.5	28.0	12.7	15.8	14.9	12.1	11°	2.4

For every rotation of the driver, the Lordotic implants increase in height by approximately 0.5mm and in lordosis by approximately 1°.

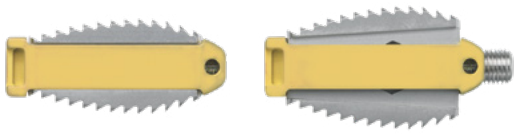

Hyperlordotic

Size	Part Number	Width (mm)	Length (mm)	Started Height (mm)	Expanded Height (mm)	Expanded Anterior Height (mm)	Expanded Posterior Height (mm)	Max Lordosis	Expansion Drive (mm)
8.5mm H x 10mm W x 24mm L	28-4142	10.5	24.5	8.5	11.7	11.3	7.5	17°	3.4
10.5mm H x 10mm W x 24mm L	28-4144	10.5	24.5	10.5	13.7	12.8	8.2	23°	3.4
12.5mm H x 10mm W x 24mm L	28-4146	10.5	24.5	12.5	15.6	14.7	10.1	23°	3.4
8.5mm H x 10mm W x 28mm L	28-4182	10.5	28.0	8.5	11.9	11.5	7.3	15°	2.4
10.5mm H x 10mm W x 28mm L	28-4184	10.5	28.0	10.5	13.8	12.9	8.0	20°	2.4
12.5mm H x 10mm W x 28mm L	28-4186	10.5	28.0	12.5	15.8	14.8	10.0	20°	2.4

For every rotation of the driver, the Hyperlordotic implants increase in height by approximately 0.5mm and in lordosis by approximately 1°.

Graft Volume Chart

Part Number	Description	Unexpanded Volume (cc ³)	Total Expanded Volume (cc ³)
28-2140	6.5mm H x 10mm W x 24mm L Non-lordotic Assembly	0.186	0.583
28-2142	8.5mm H x 10mm W x 24mm L Non-lordotic Assembly	0.186	0.719
28-2144	10.5mm H x 10mm W x 24mm L Non-lordotic Assembly	0.214	0.870
28-2146	12.5mm H x 10mm W x 24mm L Non-lordotic Assembly	0.214	1.033
28-2180	6.5mm H x 10mm W x 28mm L Non-lordotic Assembly	0.239	0.665
28-2182	8.5mm H x 10mm W x 28mm L Non-lordotic Assembly	0.239	0.818
28-2184	10.5mm H x 10mm W x 28mm L Non-lordotic Assembly	0.275	0.965
28-2186	12.5mm H x 10mm W x 28mm L Non-lordotic Assembly	0.275	1.167
28-3140	6.5mm H x 10mm W x 24mm L Lordotic Assembly	0.186	0.557
28-3142	8.5mm H x 10mm W x 24mm L Lordotic Assembly	0.186	0.685
28-3144	10.5mm H x 10mm W x 24mm L Lordotic Assembly	0.214	0.817
28-3146	12.5mm H x 10mm W x 24mm L Lordotic Assembly	0.214	0.991
28-3180	6.5mm H x 10mm W x 28mm L Lordotic Assembly	0.239	0.624
28-3182	8.5mm H x 10mm W x 28mm L Lordotic Assembly	0.239	0.779
28-3184	10.5mm H x 10mm W x 28mm L Lordotic Assembly	0.275	0.934
28-3186	12.5mm H x 10mm W x 28mm L Lordotic Assembly	0.275	1.132
28-4142	8.5mm H x 10mm W x 24mm L Hyperlordotic Assembly	0.186	0.660
28-4144	10.5mm H x 10mm W x 24mm L Hyperlordotic Assembly	0.186	0.811
28-4146	12.5mm H x 10mm W x 24mm L Hyperlordotic Assembly	0.214	0.938
28-4182	8.5mm H x 10mm W x 28mm L Hyperlordotic Assembly	0.239	0.743
28-4184	10.5mm H x 10mm W x 28mm L Hyperlordotic Assembly	0.239	0.907
28-4186	12.5mm H x 10mm W x 28mm L Hyperlordotic Assembly	0.275	1.053

Warning: Do not place bone graft in the graft window prior to final positioning and expansion of the implant. The bone graft will block the insertion of the Implant Driver into the Implant Expansion Drive.

Implants

Part #	Description	Qty
Non-Lordotic		
28-2140	6.5mm H x 10mm W x 24mm L	2
28-2142	8.5mm H x 10mm W x 24mm L	3
28-2144	10.5mm H x 10mm W x 24mm L	1
28-2180	6.5mm H x 10mm W x 28mm L	1
28-2182	8.5mm H x 10mm W x 28mm L	1
Lordotic		
28-3140	6.5mm H x 10mm W x 24mm L	3
28-3142	8.5mm H x 10mm W x 24mm L	3
28-3144	10.5mm H x 10mm W x 24mm L	2
28-3180	6.5mm H x 10mm W x 28mm L	1
28-3182	8.5mm H x 10mm W x 28mm L	2
28-3184	10.5mm H x 10mm W x 28mm L	2
Hyper-Lordotic		
28-4142	8.5mm H x 10mm W x 24mm L	2
28-4144	10.5mm H x 10mm W x 24mm L	1
28-4182	8.5mm H x 10mm W x 28mm L	1
28-4184	10.5mm H x 10mm W x 28mm L	1

Optional Implants

Part #	Description
Non-Lordotic	
28-2146	12.5mm H x 10mm W x 24mm L
28-2184	10.5mm H x 10mm W x 28mm L
28-2186	12.5mm H x 10mm W x 28mm L
Lordotic	
28-3146	12.5mm H x 10mm W x 24mm L
28-3186	12.5mm H x 10mm W x 28mm L
Hyper-Lordotic	
28-4146	12.5mm H x 10mm W x 24mm L
28-4186	12.5mm H x 10mm W x 28mm L

Instruments

Part #	Description	Qty
28-1101	Implant Inserter	2
28-1003	Implant Remover	1
28-1004	Implant Remover Driver	1
28-1006	6.5mm H x 10mm W Trial	1
28-1008	8.5mm H x 10mm W Trial	1
28-1010	10.5mm H x 10mm W Trial	1
28-1021 or 28-1031	Axial Torque Limiting Handle	1
28-1023	Funnel	1
28-1027	Slap Hammer	1
28-1102	Stabilizer Driver, 24mm	2
28-1103	Stabilizer Driver, 28mm	2
28-1104	Driver Adapter	2
28-1124	Funnel Plunger	1

Optional Instruments

Part #	Description
28-1012	12.5mm H x 10mm W Trial
28-1132	Torque Limiting Handle (T-Handle)

Note: Many optional implants are not stocked and have a minimum 12 week lead time.

FORZA Discectomy Case 89-0031

Part #	Description	Qty
Top Tray		
89-0300	Anatomic Rasp	1
89-0301	Flat Rasp	1
89-0303	Curved Rasp	1
89-0600	Nerve Root Retractor, 70°	1
89-0601	Nerve Root Retractor, 90°	1
89-0602	Malleable Nerve Root Retractor	1
89-0650	2mm Pituitary Rongeur - Straight Biting	1
89-0651	2mm Pituitary Rongeur - Up Biting	1
89-0652	4mm Pituitary Rongeur - Straight Biting	1
89-0653	4mm Pituitary Rongeur - Up Biting	1

Middle Tray

89-0372	#0 Curette Straight- Serrated	1
89-0373	#1 Curette Straight- Serrated	1
89-0376	#0 Curette Up- Serrated	1
89-0377	#1 Curette Up- Serrated	1
89-0380	#0 Curette Down- Serrated	1
89-0381	#1 Curette Down- Serrated	1
89-0385	#1 Curette Right- Serrated	1
89-0389	#1 Curette Left- Serrated	1
89-0390	Small Ring Curette - 6W x 10L	1
89-0391	Large Ring Curette - 10W x 10L	1

Bottom Tray

89-0250	6mm Paddle Distractor	1
89-0251	7mm Paddle Distractor	1
89-0252	8mm Paddle Distractor	1
89-0253	9mm Paddle Distractor	1
89-0254	10mm Paddle Distractor	1
89-0255	11mm Paddle Distractor	1
89-0256	12mm Paddle Distractor	1
89-0257	13mm Paddle Distractor	1
89-0258	14mm Paddle Distractor	1
89-0259	15mm Paddle Distractor	1
89-0260	16mm Paddle Distractor	1

Part #	Description	Qty
Bottom Tray (cont.)		
89-0406	6mm Rotating Cutter	1
89-0407	7mm Rotating Cutter	1
89-0408	8mm Rotating Cutter	1
89-0409	9mm Rotating Cutter	1
89-0410	10mm Rotating Cutter	1
89-0411	11mm Rotating Cutter	1
89-0412	12mm Rotating Cutter	1
89-0413	13mm Rotating Cutter	1
89-0414	14mm Rotating Cutter	1
89-0415	15mm Rotating Cutter	1
89-0416	16mm Rotating Cutter	1

Discectomy Case

89-0092	Discectomy Case and Trays
---------	---------------------------

Order by Request - Discectomy Instruments

89-0351	#00 Curette Straight - Smooth
89-0353	#1 Curette Straight - Smooth
89-0355	#00 Curette Up - Smooth
89-0356	#0 Curette Up - Smooth
89-0357	#1 Curette Up - Smooth
89-0359	#00 Curette Down - Smooth
89-0360	#0 Curette Down - Smooth
89-0361	#1 Curette Down - Smooth
89-0364	#0 Curette Right - Smooth
89-0365	#1 Curette Right - Smooth
89-0368	#0 Curette Left - Smooth
89-0369	#1 Curette Left - Smooth
89-0342	#00 Curette 90° Down - Smooth
89-0343	#0 Curette 90° Down - Smooth
89-0344	#1 Curette 90° Down - Smooth
89-0346	#00 Curette 90° Down - Serrated
89-0347	#0 Curette 90° Down - Serrated
89-0348	#1 Curette 90° Down - Serrated

Please visit [Orthofix.com/IFU](https://www.orthofix.com/IFU) for full information on indications for use, contraindications, warnings, precautions, adverse reactions and sterilization.

Caution: Federal law (USA) restricts this device to sale by or on the order of a physician. Proper surgical procedure is the responsibility of the medical professional. Operative techniques are furnished as an informative guideline. Each surgeon must evaluate the appropriateness of a technique based on his or her personal medical credentials and experience.



Orthofix
3451 Plano Parkway
Lewisville, Texas 75056-9453 USA
1.214.937.3199
1.888.298.5700
www.orthofix.com



Medical Device Safety Services (MDSS):
Schiffgraben 41
30175, Hannover
Germany
www.mdss.com

Rx Only
CE²⁷⁹⁷

Orthofix products or services referenced herein are trademarks or registered trademarks of Orthofix Medical Inc. and its group of companies. Any rights not expressly granted herein are reserved.