

VENUS_{nano}

Paediatric Fixation System

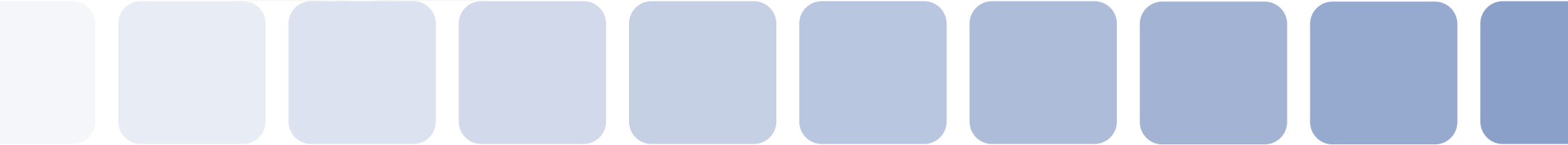

The VENUSnano spinal system is a follow-on product of the VENUS system and has been developed for use in the thoracic, lumbar and sacral spine region in children and adults of small stature. It may be used mono-segmentally as well as multi-segmentally. The system stands out due to its high degree of biomechanical stability and user-friendliness. Long head screws and hooks are included too.

Implants for primary fusion and revision surgery

The VENUSnano spinal system is extremely well suited for use in almost all indications of medical conditions requiring surgery and injuries to the thoracic, lumbar and sacral spine, such as instability, degenerative disc disorders, degenerative spondylolisthesis, degenerative stenosis, deformities such as scoliosis and kyphosis, fractures and spondylitis as well as revision surgery. The dorsal instrumentation alone is not usually enough to establish the necessary degree of stability of a spinal segment in cases of tumour-related or traumatic destruction of the segment with loss or absence of the ventral column. Such cases may require supplementary anterior support including vertebral body replacement implants.

We develop and produce all our implants and instruments in Germany, and will continue to do so. To us, Made in Germany is a special quality label, one which we are proud of. Our HumanTech expert team operates all over the world. Solid market analysis and active, renowned surgeons provide us with the know-how for our development and production processes.

The perfectly crafted VENUSnano implant and instrument system meets every requirement when it comes to style, stability, handling, aesthetics and quality, and conforms to the highest international standards. With the specially developed thread design, the screws can be introduced incredibly gently and are capable of withstanding maximum loading. Our transverse connectors and rods are of outstanding quality. The instruments are highly ergonomic, winning users over with their ease of use.

Product-specific advantages

- Modular system
- Simple and precise placement reduction
- Gentle reduction
- Design perfectly adapted to the anatomy
- Secure primary fixation while preserving the tissue at the same time
- Optimum osseointegration of the implant due to special surface structure
- Maximum biomechanical stability
- In-house development and production

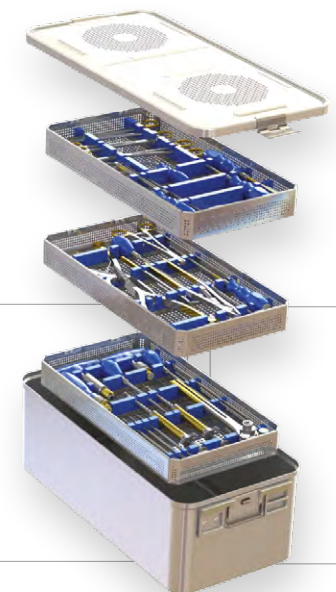

VENUSnano

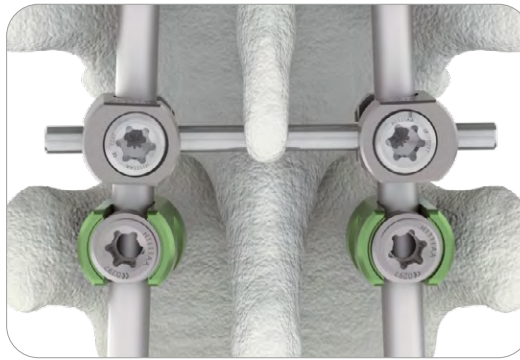

- safe
- anatomical
- transparent
- stable
- flexible

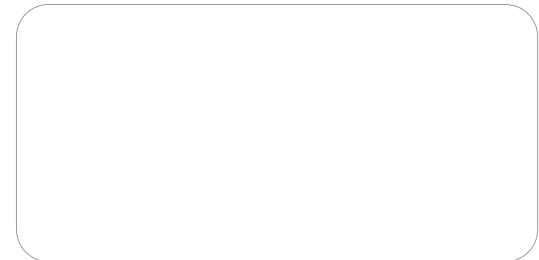
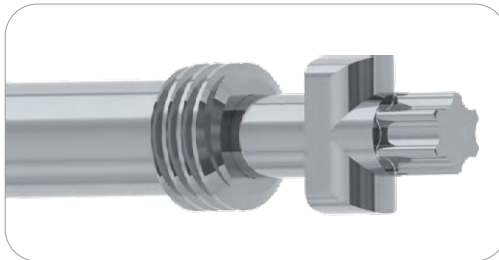
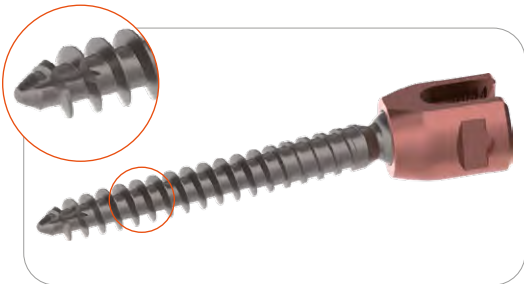

Screws

The screws in the VENUSnano system have low-profile threads to preserve soft tissue and generate minimal trauma in the bone, too. Despite this, the screw still manages to engage the bone immediately while being screwed in. The rounded screw tip is also suitable for anterior fixation due to its profile. The gradient of the screw thread enables the screw to be screwed into the bone quickly and precisely, yet safely. The four different angles in the thread profile guarantee an optimum fit in the bone and thus a secure primary fixation. The surface structure then enables optimum osseointegration of the implant. The long head screws enable the correction and stabilisation of the spine in particularly complicated anatomies. The screw has a detachable screw head extension with an inner thread, using which it is possible to approximate the spine to the desired sagittal or axial profile. The possibilities of this include the reduction of three-dimensional deformities, including kyphosis or spondylolisthesis.



Hooks

VENUSnano pedicle and lamina hooks complement the screws perfectly. They enable the correction and stabilisation of the spine in particularly complicated anatomies. These can be attached at the pedicle, the transverse process as well as supra-laminar and intra-laminar, both thoracic as well as lumbar. This possibilities of this include the reduction of three-dimensional deformities, including kyphosis or scoliosis. The comprehensive selection of pedicle and lamina hooks as well as domino and lateral connectors maximize the surgeon's intraoperative flexibility and allow him/her enhanced precision with faster and safer implantation.



Rods

The 4.5mm rods in varying lengths reduce the effort involved in cutting the rods to length during the OP to a minimum. Nitinol phantom rods and special alignment markers on the rods enable the rod to undergo optimum preparation before being penetrated into the structure. Rods with hexagonal-shaped ends allow the rod to be rotated before the final fixation, thus making it possible to perform simple corrections of deformities.

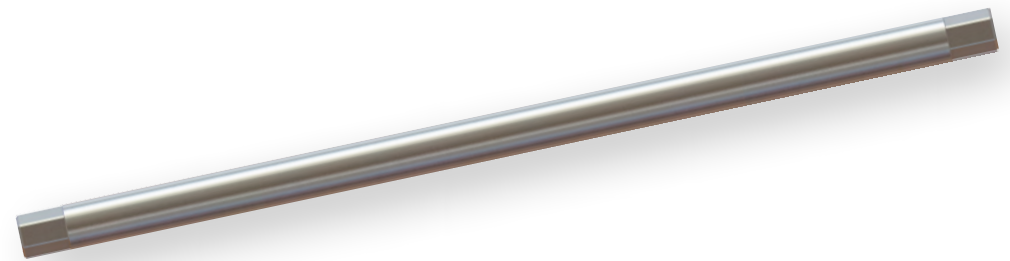

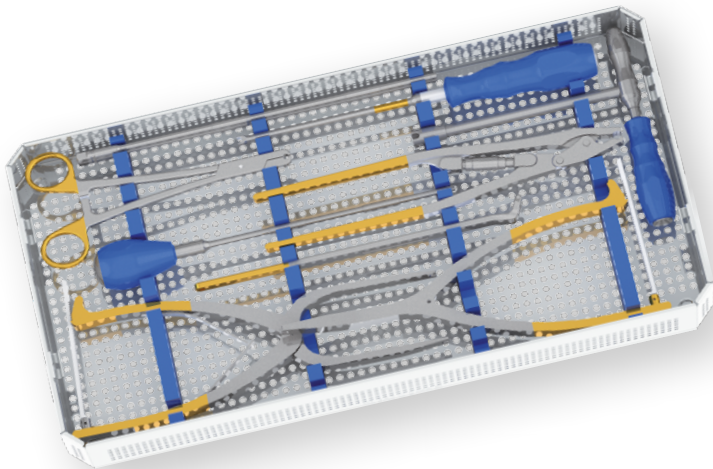
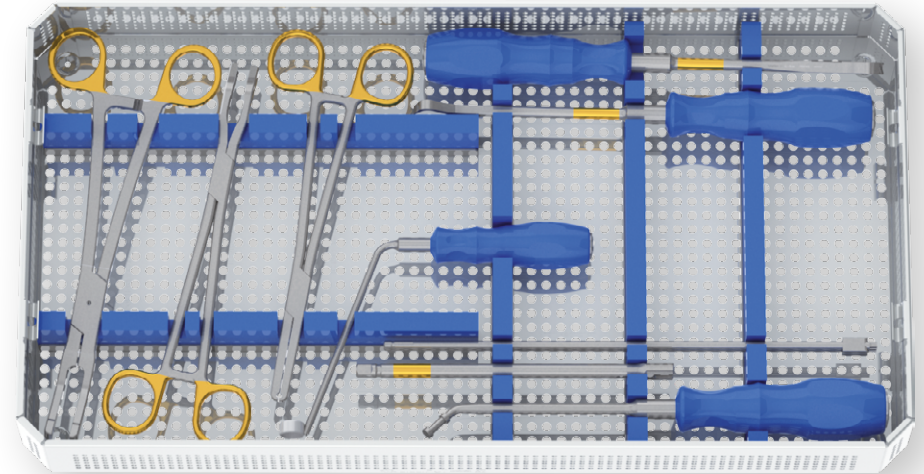
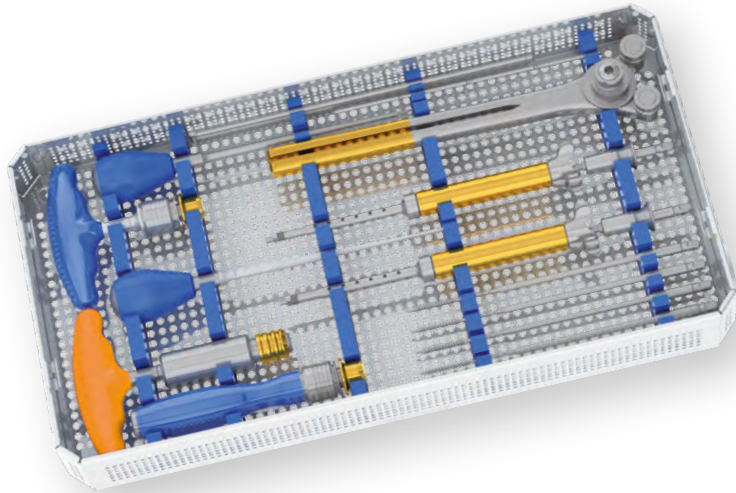

Instruments

The VENUSnano instrument set, a follow-on product of the tried and tested Venus instrument set, is among the most outstanding surgical instrumentation systems.

The system is the exclusive product of “Made in Germany” engineering skill in line with ISO and EC specifications. The perfection of the instrument set can also be attributed to its simplicity, which ensures optimum sterilisation as well as safe and easy use. Highly-qualified quality management, accurate testing methods and complete traceability ensure the highest production standard, something that our customers can always rely on. Quality and precision are our incentive for developing new, ground-breaking and more effective ways of improving the VENUSnano instrument system. Close contact with users is critical for our developments in this process.

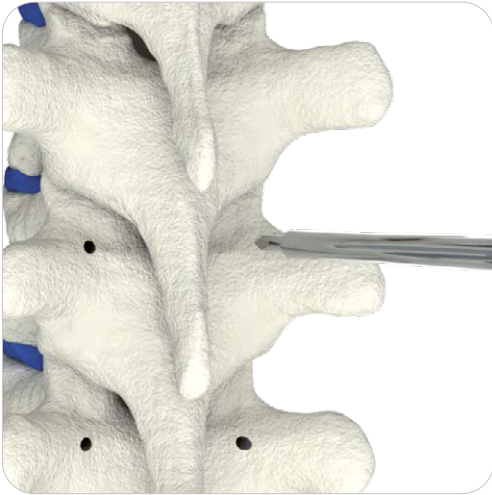

Preparing the pedicle

Set the pedicle insertion point. Open the pedicle canal using the awl.

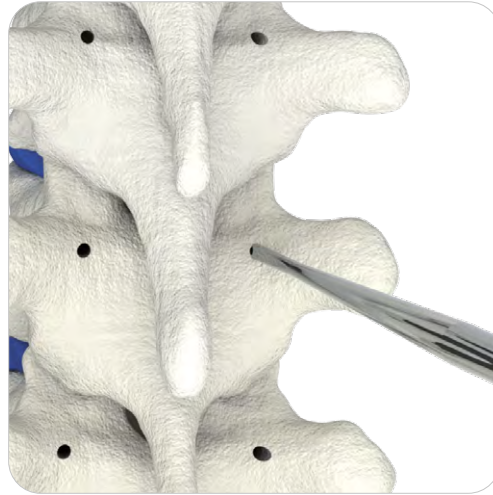

Awling and probing

The pedicle canal is awled. Using light pressure, the awl is advanced (Pedicle Probe) into the pedicle canal carefully in half rotations.

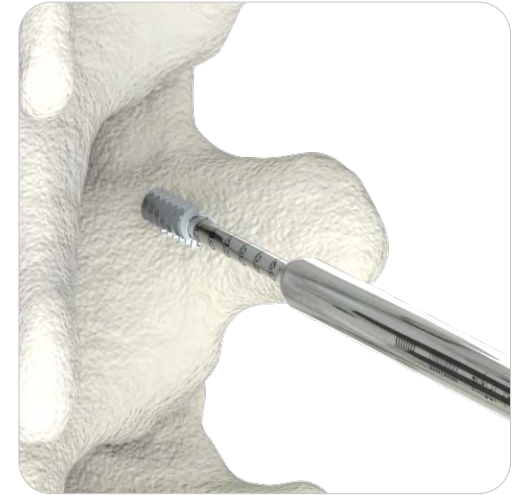

Tapping

All pedicle screws are self-tapping. In cases where there is a very rigid bone structure, making the use of a tap necessary, taps are available to suit all screw diameters.

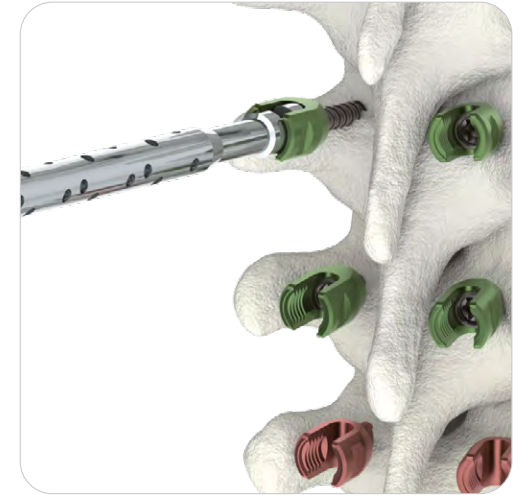
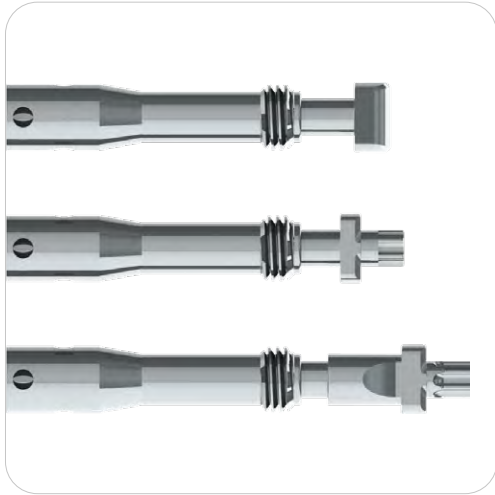

There are various screw driver shafts available for inserting the screws. Depending on the type of screw, insert the inner screwdriver shaft into the LP mono-/poly-axial screw driver guide and secure with the locking adapter (see below).

Now insert the tip of the screw driver (inner shaft) depending on the type of screw (mono/poly or reduction) into the screw head and connect the outer guide to the screw head by screwing it into the inner thread of the screw head.

The screw is screwed into the pedicle canal. After screwing it into the final position, release the screwdriver. In order to do so, grip the handle and turn the outer nut counter-clockwise (see below).

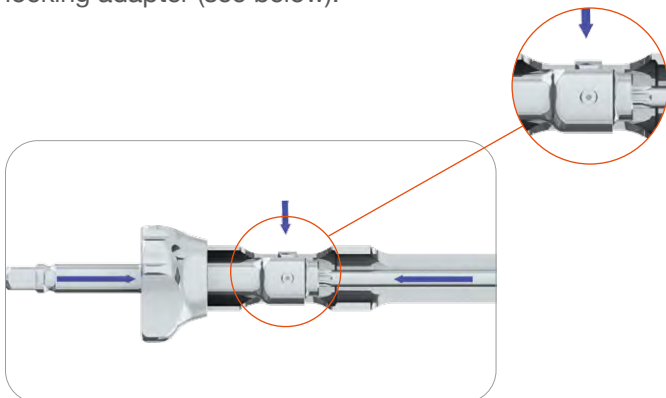

Note:
When fitting the screws (poly/reduction), it must be ensured that the hexalobular head bolt is fitted properly in the recess of the screw.



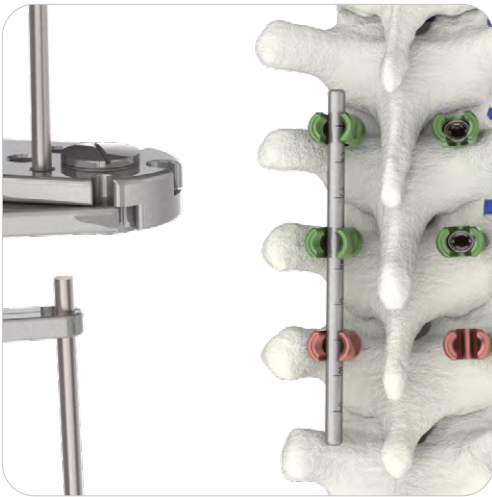

Inserting the rod

Set the rod length. A phantom rod is contained in the instruments to make it easier to set the rod length. Insert the rod into the screw heads using the LP rod inserter and, if need be, with the help of your fingertips. The rod profile undergoes fine tuning and the rod is bent to the corresponding radius. If necessary, place the rod using an LP rod pusher or a rocker to ensure the correct positioning in the screw head.

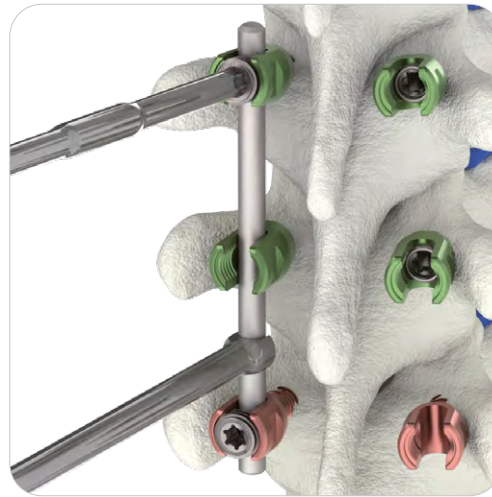

Fixing the rod

Fix the rod in the screw head with the set screw using the LP setscrew inserter. To prevent cross-threading while screwing in the set screw, first screw in a counter-clockwise direction until you clearly feel the thread “click into” the screw head. Then continue to screw in the set screw.

Caution!

Be sure to only screw in the set screw loosely; the final torque is applied using the LP set screwdriver.

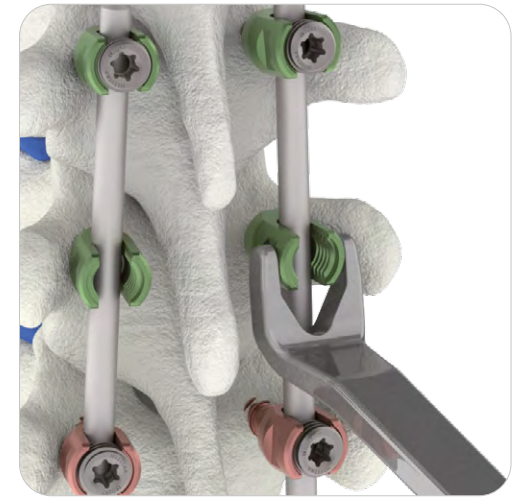

Using the rocker

Position the rocker on the screw head by inserting the fork ends into the lateral grooves of the screw head. Crank the rocker shaft until it is sitting on the rod. Then continue to crank it carefully, making visual and, if need be, x-ray checks until the rod and the screw head are interlocked. Insert the set screws and fix the rod in the screw head.

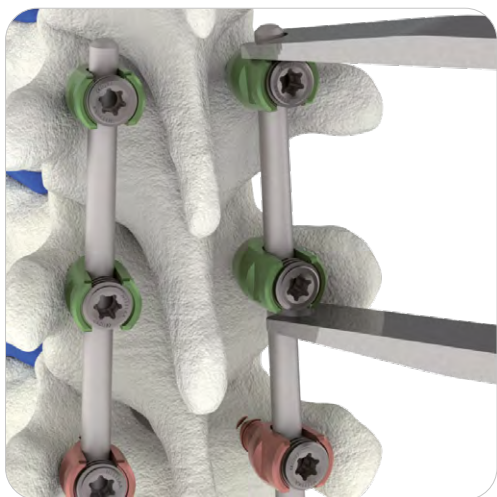

Compression-Distraction

Position the LP compressor or LP distractor on the screw heads and carry out the compression or distraction procedure until the desired position has been achieved. Insert the set screws using the setscrew inserter to ensure the compression or distraction result. Tighten using the LP setscrew driver.

Note:

The set screws must not be fully tightened during this manoeuvre. If need be, loosen the set screws carefully using the LP setscrew driver.

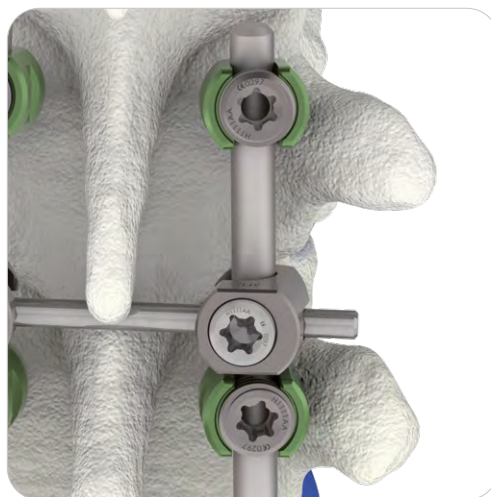

Transverse Stabiliser

Attach a transverse stabiliser hook with the help of the LP transverse connector inserter. Connect the second hook with the transverse connector rod which is inserted via the LP transverse connector rod holder and attach it to the second rod of the instrument. Align the elements and connect the transverse connector hooks using the transverse connector rod. Screw the set screws all the way into the transverse connector hook using the LP setscrew driver.

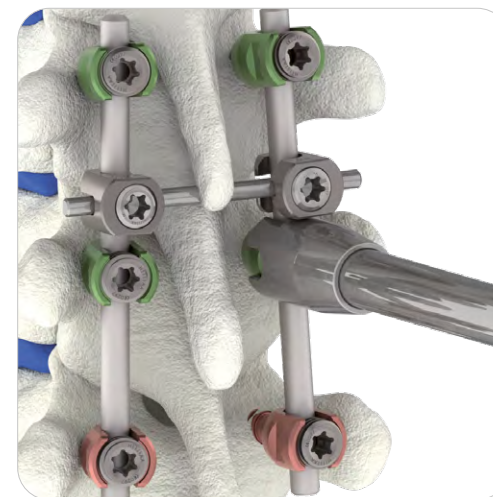

Subsequent Tightening

Slot the LP setscrew driver and the LP torque driver into one another, and then insert both components into the LP counter holder. Attach the combined instrument to the screw head. It is also possible to attach the two instruments separately. Tighten the set screw. Same approach for all other set screws.

Note:

The full torque of 10Nm is reached when an audible signal is heard.

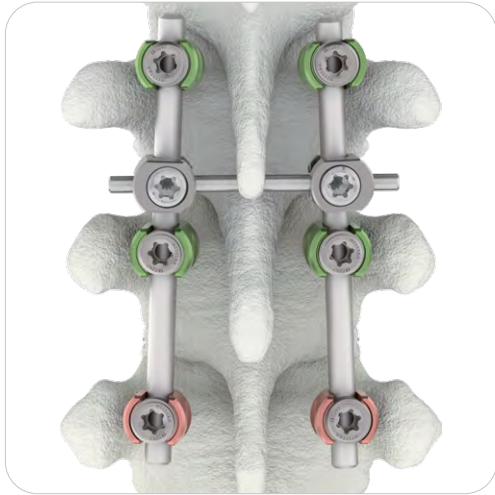

Final Structure

Final check on the structure with X-ray control images taken in two planes. Cleanse the surgical area and wound closure.

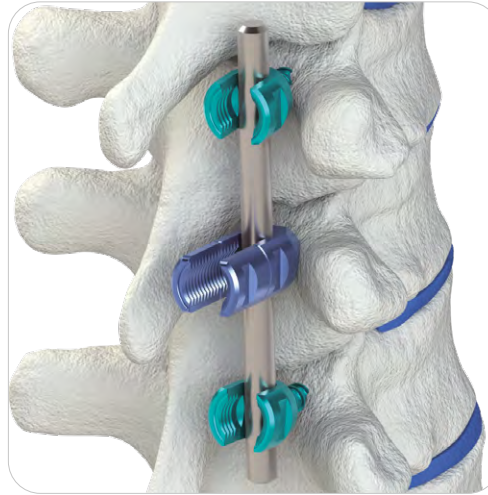

Inserting the rod for reduction/reposition

Insert the rod into the screw heads using the LP rod inserter and, if need be, with the help of your fingertips. The rod profile undergoes fine tuning and the rod is bent to the corresponding radius. If necessary, place the rod using an LP rod pusher or a rocker to ensure the correct positioning in the screw head.

Note:

When inserting the rod, care should be taken to ensure as little tension as possible in order to prevent the long flanks from breaking prematurely.

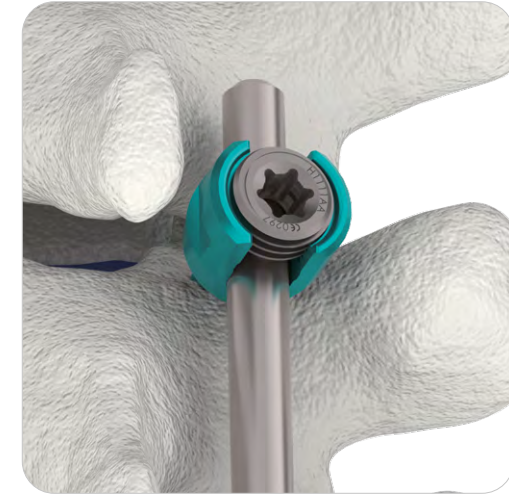

Fixing the rod

Fix the rod into the segment above and below. The segment in question with the reduction screw should remain unfixed initially. If need be, distraction can be carried out between the segments above and below to free up the segment to be reduced considerably.

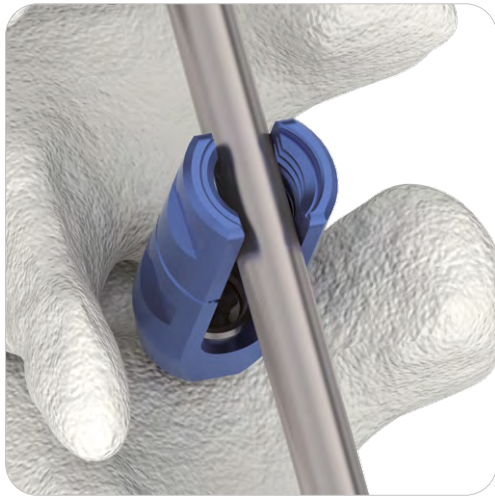

Reduction

In order to be able to carry out the reduction process in as gentle a manner and with as little tension as possible, the rod must be inserted at least to the upper end of the reduction screw. If necessary, this position can be achieved by gently pulling the rocker. In order to protect the screw flanks from breaking off: Attach the LP long head sleeves and simultaneously guide them during the screw-in process of the setscrew. Carefully screw in the setscrew while making visual checks or, if need be, x-ray checks until the rod interlocks into the screw head.



Removing the long flanks

Break off the protruding long flanks using the LP crown breaker. Slide the LP crown breaker over the flanks. The flanks break off after several lever movements (medial-lateral) at the designated breaking point. Preferably break the flank in the direction of the centre of the spine. The crown breaker is designed in such a way that the fragment remains in the instrument. The special screw head design prevents a burr formation at the breakage points.

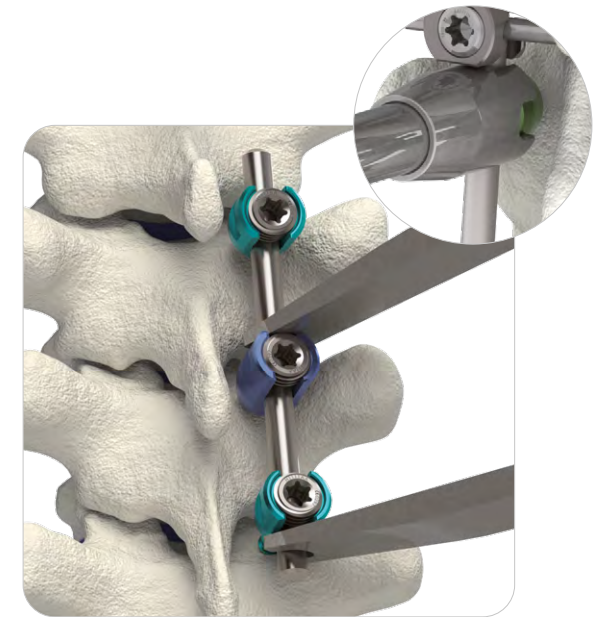

Compression / Distraction

Fix the rod into the segment above and below. The segment in question with the reduction screw should remain unfixed initially. If need be, distraction can be carried out between the segments above and below to free up the segment to be reduced considerably. Attach the combined instrument to the screw head. It is also possible to attach the two instruments separately (first LP counter holder, then LP setscrew driver with LP torque driver - max. 10Nm). Tighten the set screw. Same approach for all other set screws.

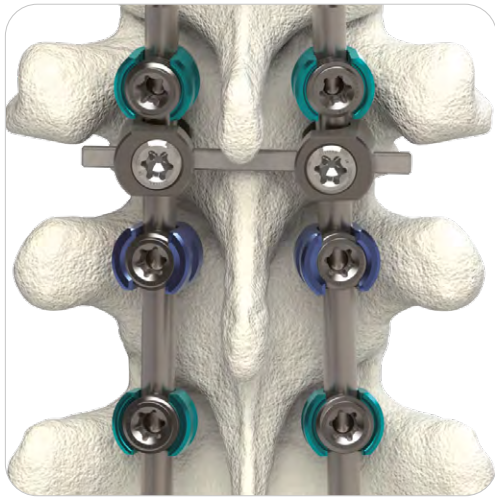

Final Structure

The actual correction process is usually a combination of various manoeuvres or techniques. The advantage of long head screws is that the correction is carried out slowly, and the forces are distributed across several segments. The final structure has the same biomechanical strength as a standard fixation.



Placing the pedicle hook

Pedicle hooks are available in different sizes and for different applications. Pedicle hooks can be used only in the thoracic region, in the cranial direction. For this, the caudal facet joint is resected at a right angle. Below this, the cranial articular facet of the vertebra positioned caudally of it is visible.

The pedicle is palpated using the instrumentation by undercutting the facet of the cranial vertebra on the facet which has been rendered visible.

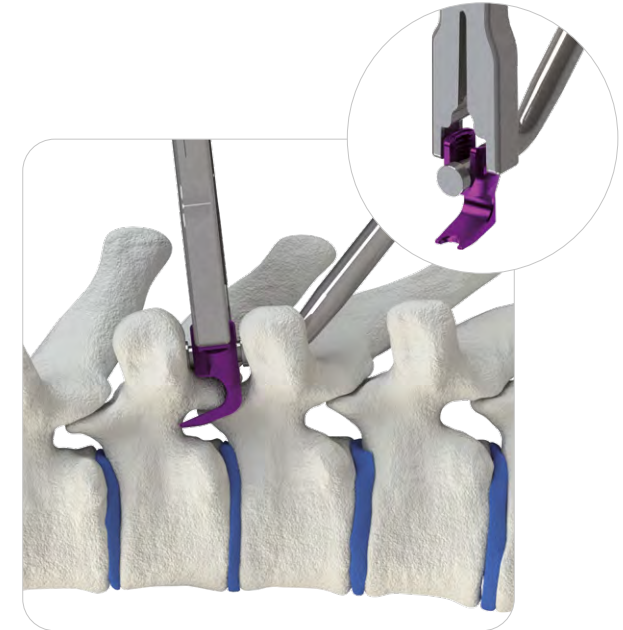

Inserting the pedicle hook

In order to facilitate the insertion of the pedicle hook, remove a small part of the lower facet with an osteotome. Insert the LP hook impactor into the LP hook holder. With this combination of instruments, the pedicle hooks can be easily pressed into the pedicle hook position. Assist with gentle hammer blows if need be.

Move the LP hook holder laterally and cranially to check for the optimum position. Do not press medially.



Placing the lamina hook

Lamina hooks are available in different sizes and for different applications. Lamina hooks can be used in both the thoracic and lumbar regions (in the caudal-cranial, cranial-caudal direction and in the transverse processes). The hook position is prepared on the transverse process by means of cranial bypass with the lamina finder. For caudal setting of lamina hooks, following a partial flavectomy the hook is placed in a supra laminar, supra thoracic or lumbar position. If necessary, the spinous processes must be shortened until the ligamentum flavum is visible.

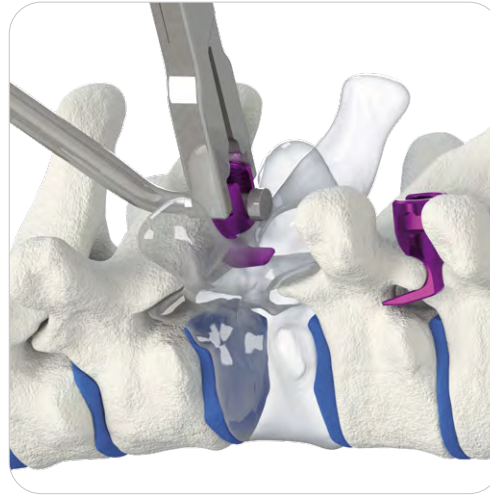

Inserting the lamina hook

For a secure identification and placement of the hook position, the ligamentum flavum is removed with a rongeur up to a point where the dura is visible. The hooks are inserted with the instrument combination LP hood, holder and LP hook inserter. Make sure that the hook is not too deep or presses on the spinal cord.

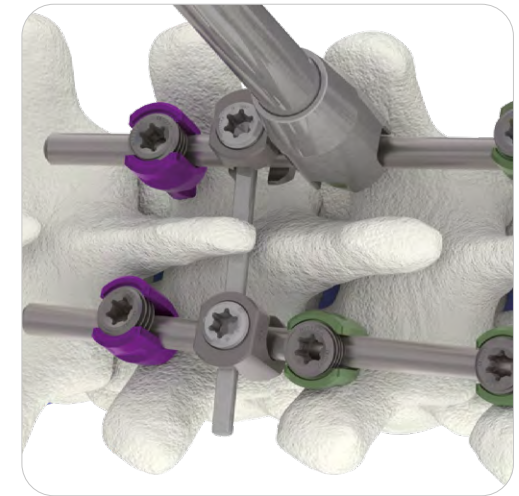

Subsequent Tightening

Slot the LP torque driver and the LP counter holder into one another. Attach the combined instrument to the screw head. It is also possible to attach the two instruments separately. Tighten the set screw. Same approach for all other set screws.

Note:
The full torque of 10Nm is reached when an audible signal is heard.



Preassembly of LP Offset Hooks

The LP Pedicle screws as well as other hooks and the rods are already installed. The seat for the LP Offset Hook is already prepared.

Preassembly of the LP Offset Hook on the LP Lateral Connector and prefixation with the LP Set Screw.



Pick up the unit

Pick the preassembled unit with the LP Rod Inserter

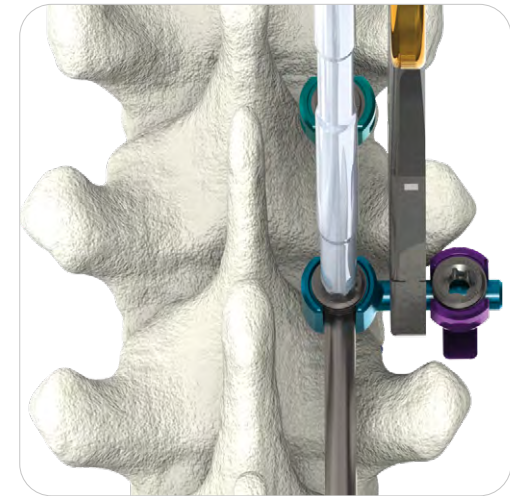

Insertion of preassembled unit

Insert the preassembled unit and prefix on the rod.

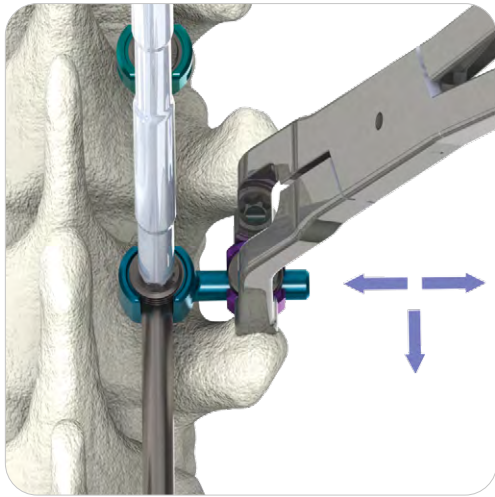

Positioning of LP Offset Hooks

Adjustment of the LP Offset Hook on the LP Lateral Connector. Then fixation of the LP Offset Hook on the prepared Seat.

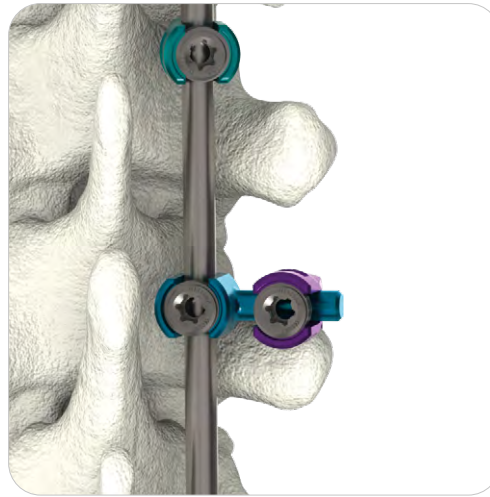

Final fixation

Final Tightening of the Setscrews as described in the Surgical Technique.

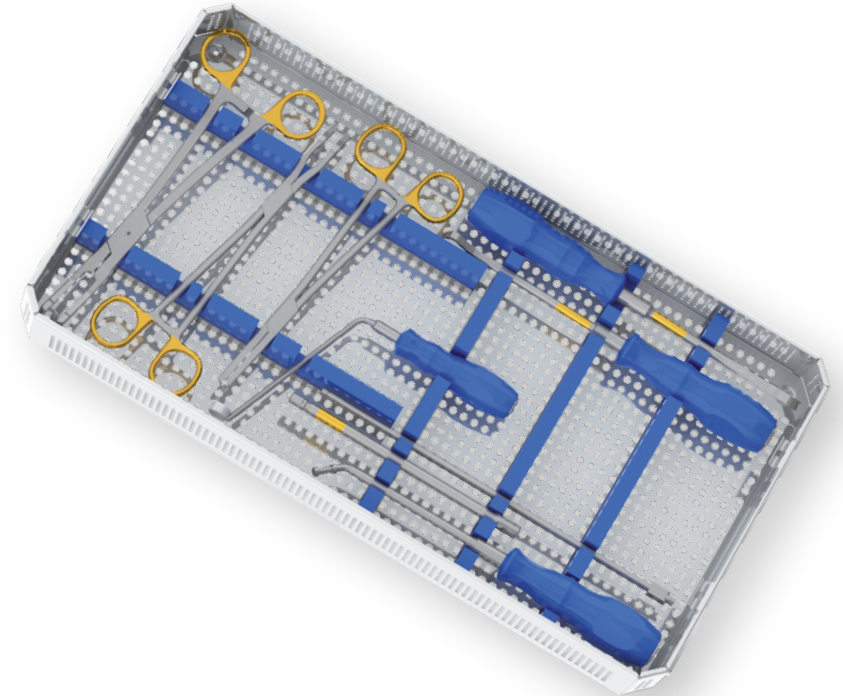

Note:

The full torque of 10Nm is reached when an audible signal is heard.



Polyaxial- und Monoaxial Screws

Art.No.	Description	Image
	Polyaxial Screws LP Ø4 mm	
2200044020	Polyaxial Screw LP Ø4x20mm	
2200044025	Polyaxial Screw LP Ø4x25mm	
2200044030	Polyaxial Screw LP Ø4x30mm	
2200044035	Polyaxial Screw LP Ø4x35mm	
2200044040	Polyaxial Screw LP Ø4x40mm	
2200044045	Polyaxial Screw LP Ø4x45mm	
	Polyaxial Screws LP Ø5 mm	
2200045025	Polyaxial Screw LP Ø5x25mm	
2200045030	Polyaxial Screw LP Ø5x30mm	
2200045035	Polyaxial Screw LP Ø5x35mm	
2200045040	Polyaxial Screw LP Ø5x40mm	
2200045045	Polyaxial Screw LP Ø5x45mm	
2200045050	Polyaxial Screw LP Ø5x50mm	
2200045060	Polyaxial Screw LP Ø5x60mm	
2200045070	Polyaxial Screw LP Ø5x70mm	
	Polyaxial Screws LP Ø5.5 mm	
2200045525	Polyaxial Screw LP Ø5.5x25mm	
2200045530	Polyaxial Screw LP Ø5.5x30mm	
2200045535	Polyaxial Screw LP Ø5.5x35mm	
2200045540	Polyaxial Screw LP Ø5.5x40mm	
2200045545	Polyaxial Screw LP Ø5.5x45mm	
2200045550	Polyaxial Screw LP Ø5.5x50mm	
2200045560	Polyaxial Screw LP Ø5.5x60mm	
2200045570	Polyaxial Screw LP Ø5.5x70mm	

Art.No.	Description	Image
	Monoaxial Screws Ø4 mm	
2200064025	Monoaxial Screw LP Ø4x25mm	
2200064030	Monoaxial Screw LP Ø4x30mm	
2200064035	Monoaxial Screw LP Ø4x35mm	
2200064040	Monoaxial Screw LP Ø4x40mm	
2200064045	Monoaxial Screw LP Ø4x45mm	
2200064050	Monoaxial Screw LP Ø4x50mm	
	Monoaxial Screws Ø5 mm	
2200065025	Monoaxial Screw LP Ø5x25mm	
2200065030	Monoaxial Screw LP Ø5x30mm	
2200065035	Monoaxial Screw LP Ø5x35mm	
2200065040	Monoaxial Screw LP Ø5x40mm	
2200065045	Monoaxial Screw LP Ø5x45mm	
2200065050	Monoaxial Screw LP Ø5x50mm	
	Monoaxial Screws Ø5.5 mm	
2200065525	Monoaxial Screw LP Ø5.5x25mm	
2200065530	Monoaxial Screw LP Ø5.5x30mm	
2200065535	Monoaxial Screw LP Ø5.5x35mm	
2200065540	Monoaxial Screw LP Ø5.5x40mm	
2200065545	Monoaxial Screw LP Ø5.5x45mm	
2200065550	Monoaxial Screw LP Ø5.5x50mm	
	Monoaxial Screws Ø6 mm	
2200066025	Monoaxial Screw LP Ø6x25mm	
2200066030	Monoaxial Screw LP Ø6x30mm	
2200066035	Monoaxial Screw LP Ø6x35mm	
2200066040	Monoaxial Screw LP Ø6x40mm	
2200066045	Monoaxial Screw LP Ø6x45mm	
2200066050	Monoaxial Screw LP Ø6x50mm	

Reduktion Screws

Art.No.	Description	Image
	Reduction Screw LP Ø4	
2200054020	Reduction Screw LP Ø4x20mm	
2200054025	Reduction Screw LP Ø4x25mm	
2200054030	Reduction Screw LP Ø4x30mm	
2200054035	Reduction Screw LP Ø4x35mm	
2200054040	Reduction Screw LP Ø4x40mm	
2200054045	Reduction Screw LP Ø4x45mm	
	Reduction Screw LP Ø5	
2200055025	Reduction Screw LP Ø5x25mm	
2200055030	Reduction Screw LP Ø5x30mm	
2200055035	Reduction Screw LP Ø5x35mm	
2200055040	Reduction Screw LP Ø5x40mm	
2200055045	Reduction Screw LP Ø5x45mm	
2200055050	Reduction Screw LP Ø5x50mm	
2200055060	Reduction Screw LP Ø5x60mm	
2200055070	Reduction Screw LP Ø5x70mm	
	Reduction Screw LP Ø5.5	
2200055525	Reduction Screw LP Ø5.5x25mm	
2200055530	Reduction Screw LP Ø5.5x30mm	
2200055535	Reduction Screw LP Ø5.5x35mm	
2200055540	Reduction Screw LP Ø5.5x40mm	
2200055545	Reduction Screw LP Ø5.5x45mm	
2200055550	Reduction Screw LP Ø5.5x50mm	
2200055560	Reduction Screw LP Ø5.5x60mm	
2200055570	Reduction Screw LP Ø5.5x70mm	

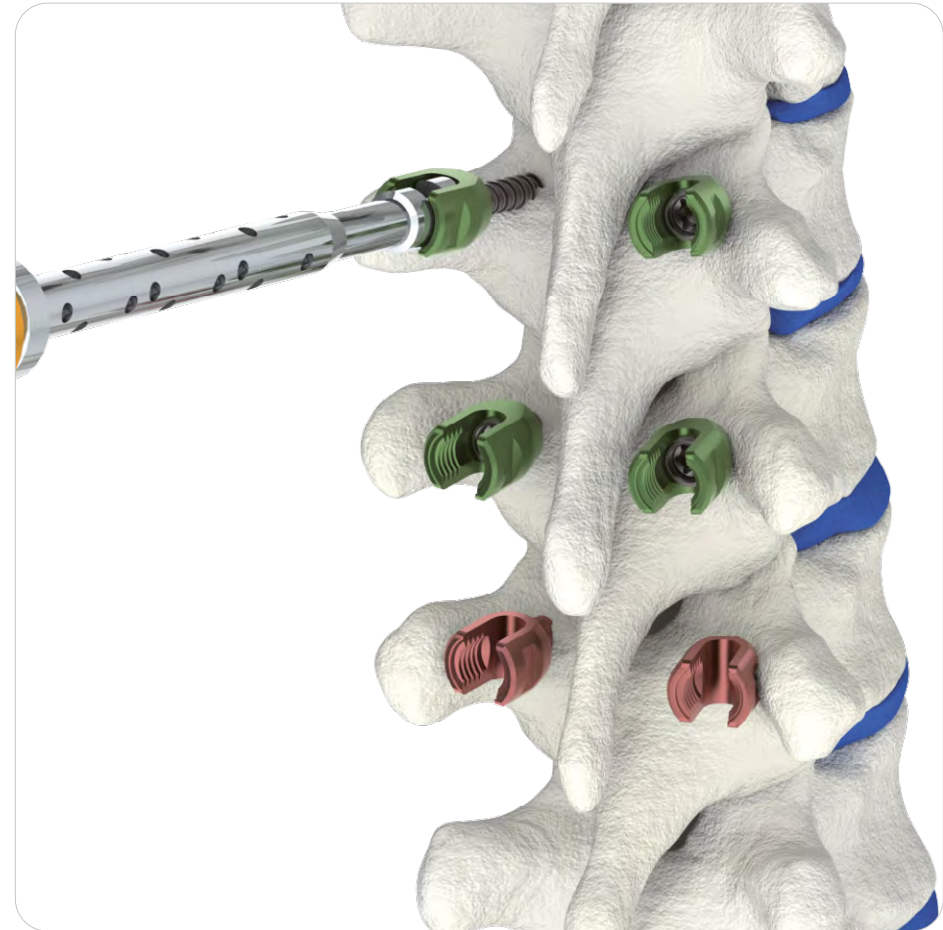

Rods and Setscrews

Art.No.	Description	Image
LP-PMS	LP Set Screw	
2200150000	LP Connector Set Screw	

Art.No.	Description	Image
2200084503	Rod straight LP CoCr Ø4.5x30mm	
2200084505	Rod straight LP CoCr Ø4.5x50mm	
2200084507	Rod straight LP CoCr Ø4.5x70mm	
2200084510H	Rod straight LP CoCr Ø4.5x100mm Hex	
2200084515H	Rod straight LP CoCr Ø4.5x150mm Hex	
2200084520H	Rod straight LP CoCr Ø4.5x200mm Hex	
2200084548H	Rod straight LP CoCr Ø4.5x480mm Hex	









Art.No.	Description	Image
2200094503	Rod straight LP Ø4.5x30mm	
2200094505	Rod straight LP Ø4.5x50mm	
2200094507	Rod straight LP Ø4.5x70mm	
2200094510H	Rod straight LP Ø4.5x100mm Hex	
2200094515H	Rod straight LP Ø4.5x150mm Hex	
2200094520H	Rod straight LP Ø4.5x200mm Hex	
2200094548H	Rod straight LP Ø4.5x480mm Hex	





Art.No.	Description	Image
2200140000	LP Transverse Connector Hook Ø4.5	
2200140040	LP Transverse Connector Rod 40mm	
2200140050	LP Transverse Connector Rod 50mm	
2200140060	LP Transverse Connector Rod 60mm	
2200140070	LP Transverse Connector Rod 70mm	
2200140080	LP Transverse Connector Rod 80mm	







Hooks and Connectors

Art.No.	Description	Image
2200100040	LP Lamina Hook 4mm	
2200100050	LP Lamina Hook 5mm	
2200100060	LP Lamina Hook 6mm	
2200101040	LP Offset Hook 4mm	
2200101050	LP Offset Hook 5mm	
2200101060	LP Offset Hook 6mm	
2200102040	LP Pedicle Hook 4mm	
2200102050	LP Pedicle Hook 5mm	
2200102060	LP Pedicle Hook 6mm	
2200100040L	LP Lamina Hook Left 4mm	
2200100050L	LP Lamina Hook Left 5mm	
2200100060L	LP Lamina Hook Left 6mm	
2200100040R	LP Lamina Hook Right 4mm	
2200100050R	LP Lamina Hook Right 5mm	
2200100060R	LP Lamina Hook Right 6mm	
Art.No.	Description	Image
2200110015	LP Lateral Connector 15mm	
2200110025	LP Lateral Connector 25mm	
2200110050	LP Lateral Connector 50mm	
Art.No.	Description	Image
2200124545	LP Domino Connector Ø4.5/4.5	
2200124555	LP Domino Connector Ø4.5/5.5	
Art.No.	Description	Image
2200134545	LP Inline Rod Connector Ø4.5/4.5	
2200134555	LP Inline Rod Connector Ø4.5/5.5	

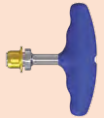
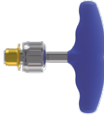
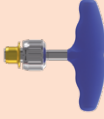
Instruments

Art.No.	Description	
2200010000	LP Awl	
2200010002	Pedicle Probe 2.5mm	
2200010003 2200010004 2200010005 2200010006	LP Tap Ø4 LP Tap Ø5 LP Tap Ø5.5 LP Tap Ø6	
2200010011	LP Rocker	
2200010008	LP Set Screw Driver	
2200010009	LP Set Screw Inserter	
2200010007	LP Counter Holder	
2200010016	LP Mono/Polyaxial Screw Driver	
2200010013	LP Reduction Crown Breaker	

Art.No.	Description	
2200010014	LP Shaft Monoaxial Screw Driver	
2200010015	LP Shaft Polyaxial Screw Driver	
2200010046	LP Shaft Reduction Screw Driver	
2200010012	LP Long Head Sleeve	

Art.Nr.	Bezeichnung		
1006010600	T-Handle Cannulated		optional
1006010701	Ratchet T-Handle Cannulated T30		
1006010711	Ratchet-ST T-Handle Can. T30		optional
1006010900	Handle Straight Cannulated		optional
1006010801	Ratchet Handle Straight Cannulated T30		
1006010811	Ratchet-ST Handle Straight Can. T30		optional
1006010501	Ratchet Handle Pear Shaped Cannulated T30		optional
1006010511	Ratchet-ST Handle Pear Shaped Can. T30		optional



Art.No.	Description
2200010017	LP Rod Inserter
2200010018	LP Rod Bender
2200010019	LP Rod Pusher
2200010020	LP Compressor
2200010021	LP Distractor
2200010022	LP TC Inserter
2200010023	LP TC Rod Holder

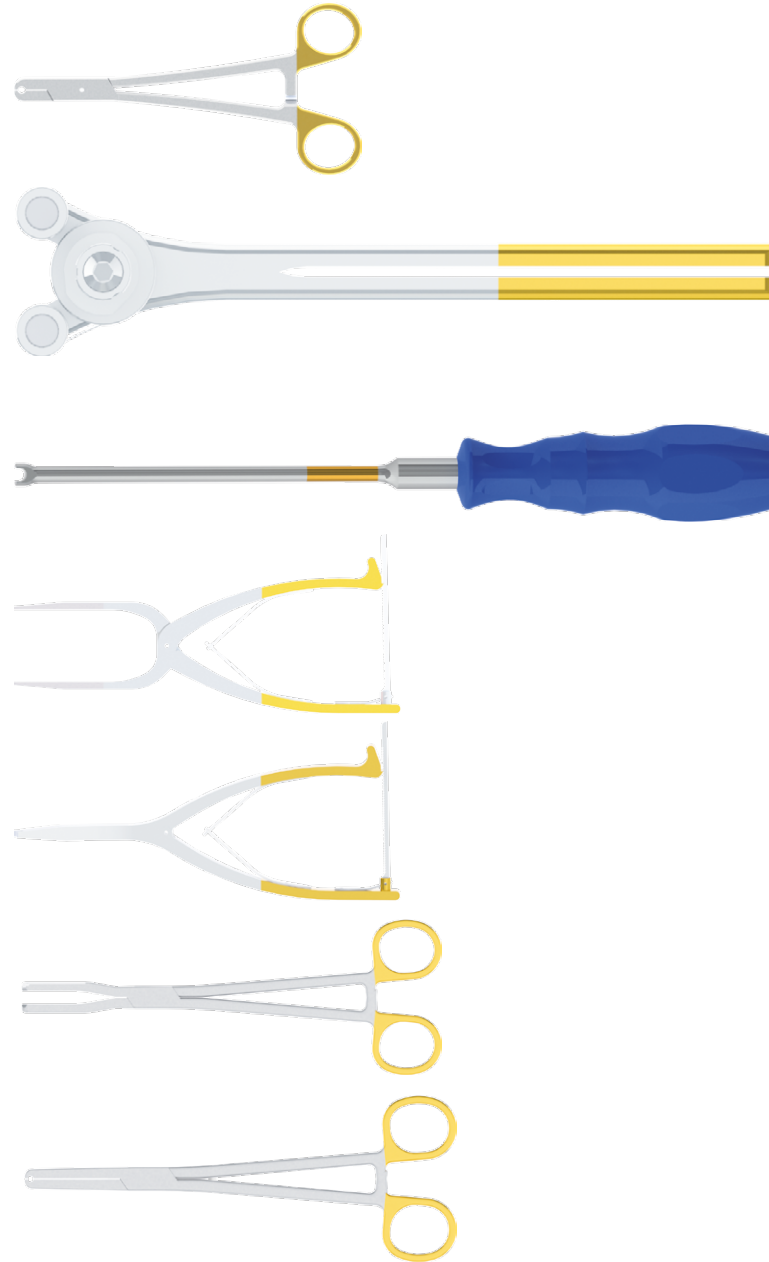

Art.No.	Description
2200010024	LP Lamina Finder
2200010025	LP Pedicle Finder
2200010031	LP Hook Impactor
2200010030	LP Hook Holder Curved
055084	Rod Cutter
2200010055	Derotation Forceps 4.5
2200010054	Torque Driver-10

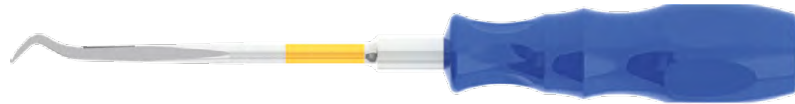

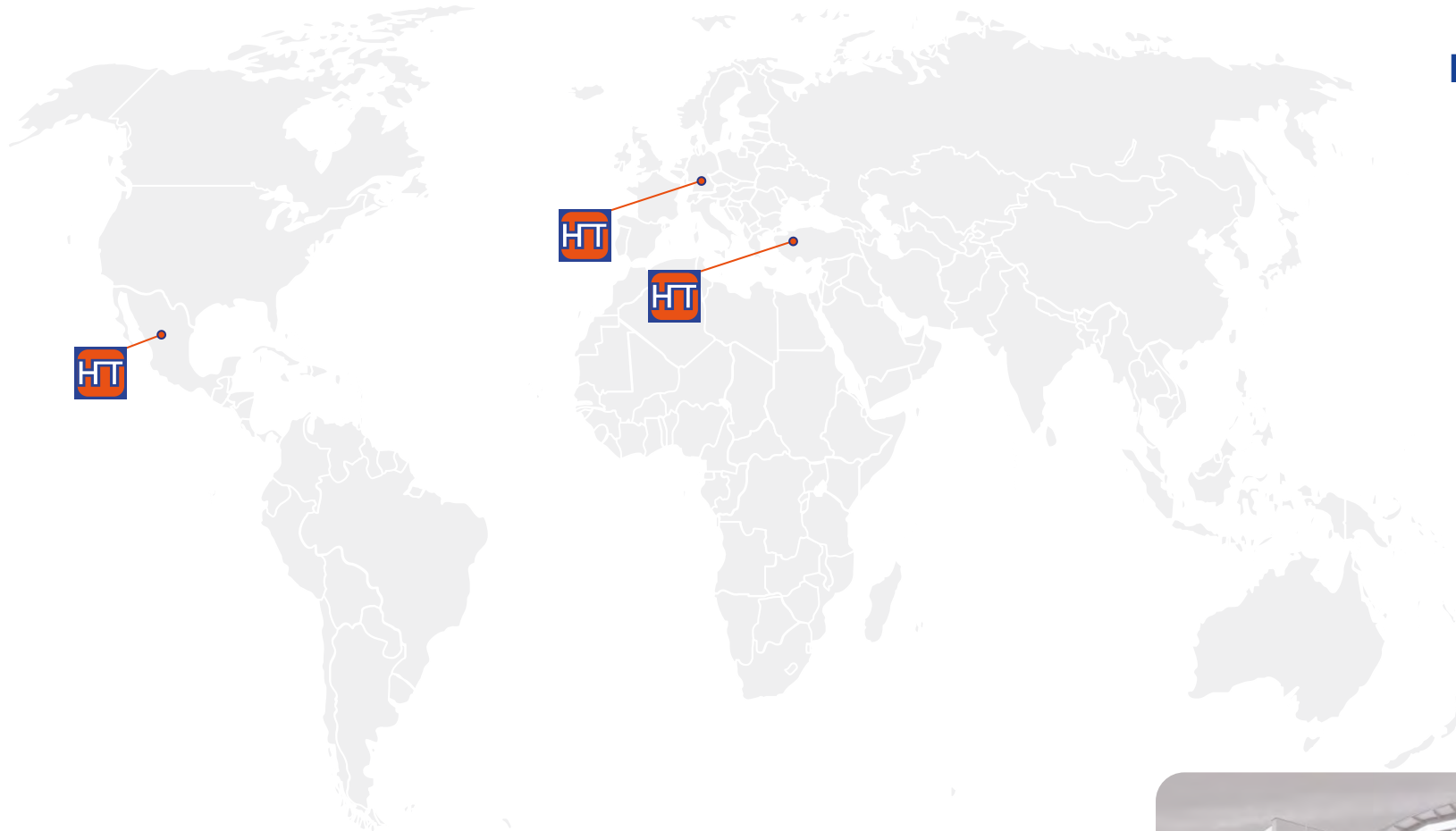

Manufacturing and sales

HumanTech Spine GmbH

Gewerbestr. 5
D-71144 Steinenbronn

Germany

Phone: +49 (0) 7157/5246-71
Fax: +49 (0) 7157/5246-66
sales@humantech-spine.de
www.humantech-spine.de

Middle East sales

HumanTech Med. Sag. Tic. Ltd.

İkitelli OSB Tümsan 2. Kısım
C-Blok No: 47
TR-34306 Başakşehir İstanbul

Turkey

Phone: +90 (0) 212/485 6675
Fax: +90 (0) 212/485 6674
info@humantech.com.tr
www.humantech-spine.de

Sales Latin America

HumanTech Mexico, S. DE R.L. DE C.V.

Rio Mixcoac No. 212-3
Acacias del Valle
Del. Benito Juárez
C.P. 03240 Mexico, D.F.
Mexico

Phone: +52 (0) 55/5534 5645
Fax: +52 (0) 55/5534 4929
info@humantech-solutions.mx
www.humantech-spine.de

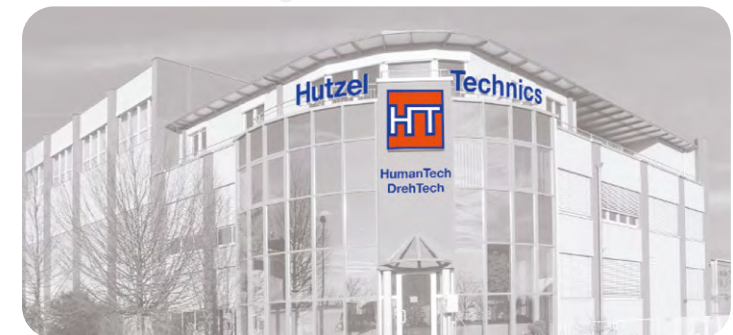

Follow us on:

