

# ANTERIOR SPINE TRUSS SYSTEM







Technology Overview ..... 4

Surgical Procedure ..... 6

Implants ..... 12

Instrumentation ..... 14

Distractor Inserter Assembly..17

Instructions For Use ..... 18

*Proper surgical procedure and technique are the responsibility of the medical professional. The following guidelines are furnished for information purposes only. Each surgeon must evaluate the appropriateness of the procedure based on his or her medical training and experience. Prior to use of the system, the surgeon should refer to the product's Instructions For Use (IFU) for complete warnings, precautions, indications, contraindications and adverse effects. IFUs are available by contacting 4WEB MEDICAL, (800) 285-7090.*





## TRUSS IMPLANT TECHNOLOGY OVERVIEW

4WEB Medical's truss implant technology leverages multidisciplinary engineering principles such as truss design, load transfer and adjacent material reaction to produce orthopedic implants that provide structural support with open space throughout the implant for bone growth and fusion.

The Anterior Spine Truss System (ASTS) contains three footprints in a variety of heights and lordotic angles to accommodate the patient's anatomy. It is not intended to be used as a stand-alone device and must be used with supplemental fixation. The ASTS implants are provided sterile.

Sizers and instruments are provided non-sterile and require sterilization prior to use.



The ASTS implant family contains three implant footprints (Small, Medium, and Large) with multiple heights and lordotic angles. Please refer to pages 12-13 for implant and sizer part numbers and dimensions.

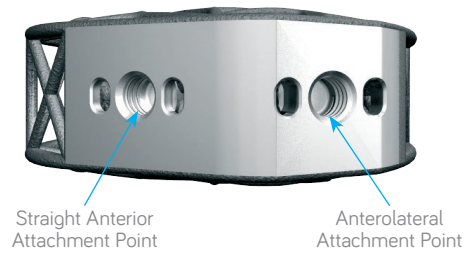
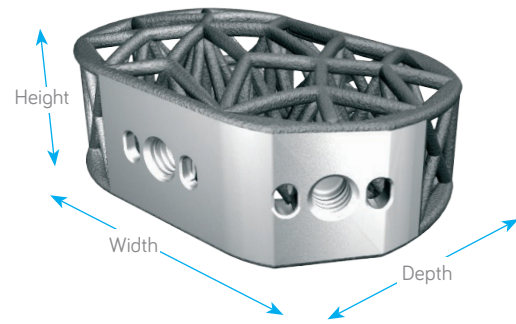

Fig.1

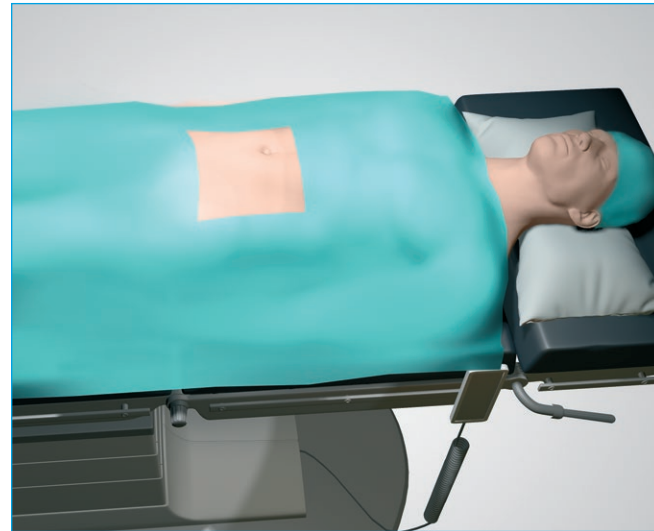

Fig. 2

**1: PRE-OPERATIVE PLANNING**

Pre-operative planning with radiographs and other advanced imaging modalities can be helpful in estimating the appropriately sized implants with the goal of restoring disc height and fractional lordosis.

Determine the surgical approach based on the surgeon's preference (straight anterior or anterolateral) (**Fig. 1**). Implants and sizers are equipped with straight and offset instrument orientations.

**NOTE:** Implants and sizers utilize the same inserter.

**2: PATIENT POSITIONING**

Place the patient in the supine position on the operating table with the lumbar spine in neutral to slight extension (**Fig. 2**).

Fluoroscopy can be utilized to aid with patient positioning.

**NOTE:** At times you may want to break the table in order to gain better access to the operative level(s), particularly when treating L5/S1.

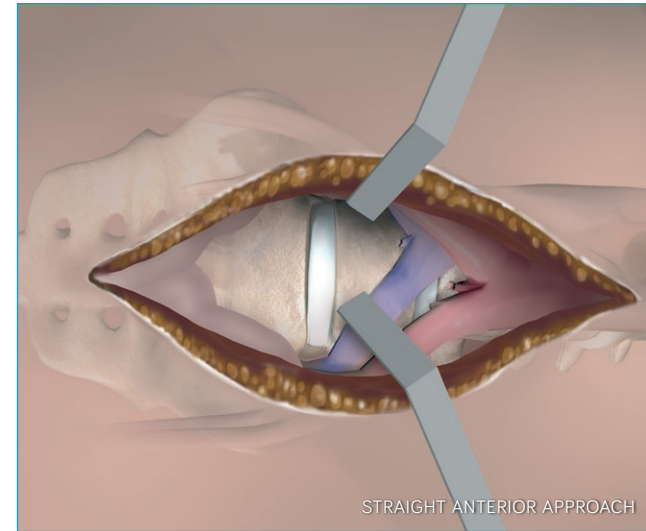

Fig. 3a

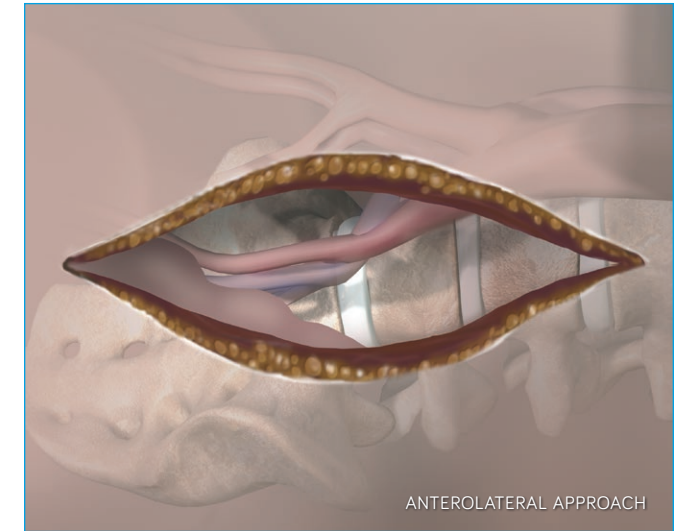

Fig. 3b

**3: ACCESS AND EXPOSURE**

Locate the correct operative level under fluoroscopic guidance. A lower abdominal transverse incision, left vertical paramedian incision, or other appropriate incision is made depending on the exposure necessary to access the operative level(s) (**Fig. 3a or 3b**).

Once the operative level(s) have been exposed, confirm the centerline of the affected level(s) with fluoroscopic imaging.

**NOTE:** Any bone removed during access and exposure may be used for autologous graft packing.

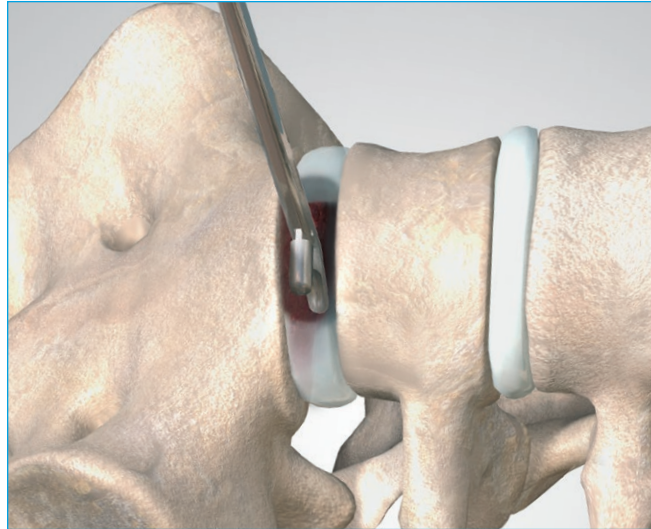

Fig. 4

#### 4: DISCECTOMY AND ENDPLATE PREPARATION

Perform an annulotomy and subsequent anterior lumbar discectomy within the constraints of the operative window (**Fig. 4**).

Remove the superficial layers of the cartilaginous endplates down to bleeding bone while trying to avoid compromising the integrity of the bony endplates.

Additional distraction may be applied as desired to increase visualization.

**NOTE:** Appropriate cleaning of the endplates is important to provide blood flow to the autologous bone packed inside the implant. Excessive cleaning, on the other hand, can weaken the endplates.

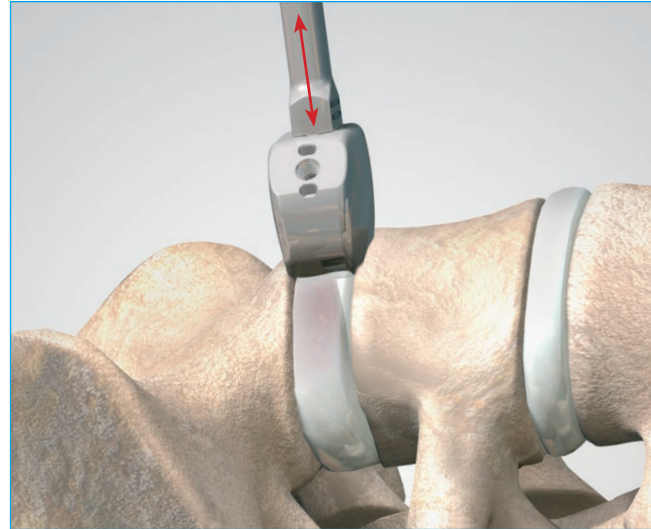

Fig. 5

#### 5: IMPLANT SIZING

Select the appropriate sizer by footprint, height and lordotic angle, and attach it to the inserter. Ensure the prongs are fully seated and no threads are visible.

Be careful not to over-tighten.

Footprint, height, and lordotic angle measurements are clearly marked on the anterior face of the sizers.

Carefully impact the sizer into the disc space (**Fig. 5**). Check the correct fit of the sizer with the aid of fluoroscopy and palpation.

If the sizer is too loose or too tight, try the next larger/smaller size until a secure fit is achieved.

Remove the sizer from the prepared disc space and select the corresponding implant.

**NOTE:** Although over distraction of the disc space is to be avoided, the largest implant that can be safely implanted in the disc space is generally the optimal implant size. Maximizing the implant surface with the vertebral endplates and providing an appropriate amount of preload through disc space distraction will help to create a stable environment conducive to new bone formation.

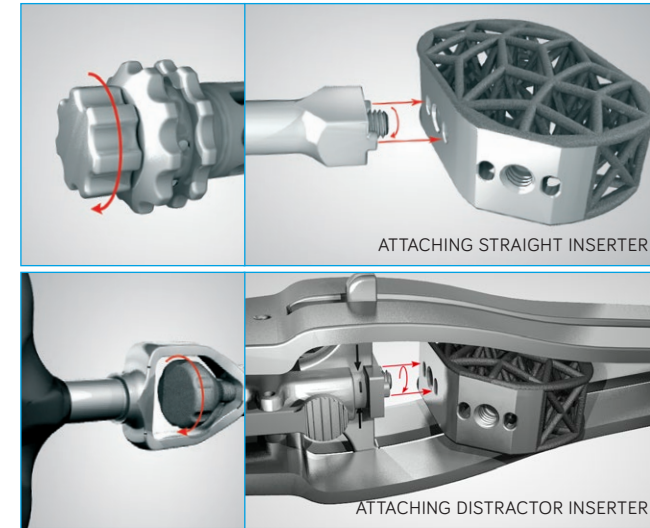

Fig. 6a

#### 6: IMPLANT PREPARATION

##### Attaching Implant Inserter:

ASTS implants are provided in a sterile package. Select the implant that corresponds to the appropriate sizer. Open the implant package using proper sterile technique.

Attach the implant to the inserter (**Fig. 6a**). Ensure the prongs are fully seated and no threads are visible.

Be careful not to over-tighten.

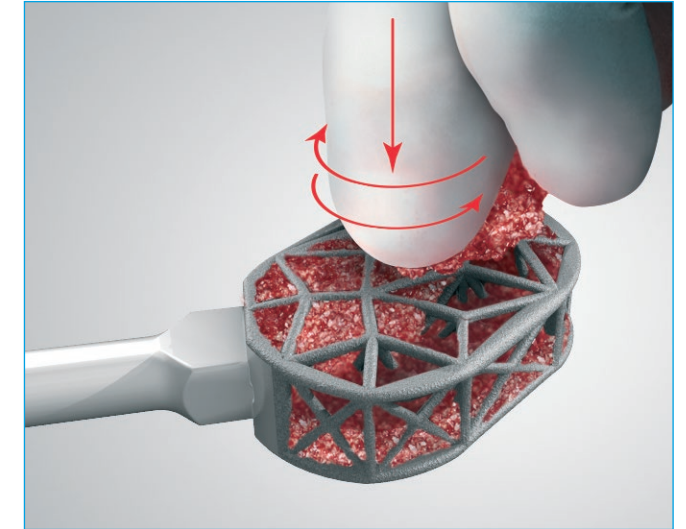

Fig. 6b

##### Packing Implant:

Pack the implant with autologous bone graft. For best results, cut or morselize the autologous bone into 1–2mm sized particles. Place the morselized bone into the top or bottom web structure (top and bottom are interchangeable). In a downward, circular motion, massage the bone particles into the implant (**Fig. 6b**).

Once packing has been completed through the top web structure, turn the implant over and repeat the placement of bone into the bottom web structure. Pack autologous bone into the implant as appropriate.



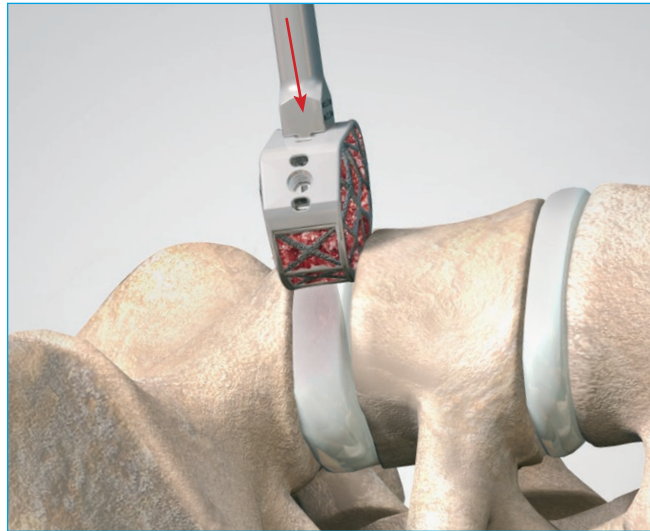

Fig. 7a

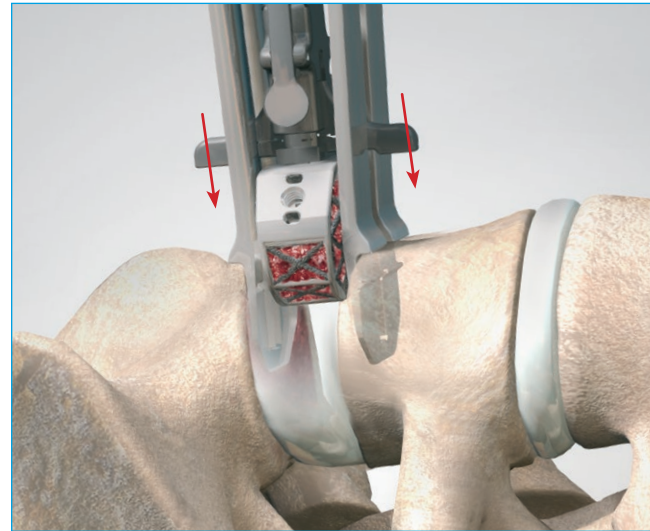

Fig. 7b

#### 7: IMPLANT INSERTION

Introduce the implant into the prepared intervertebral space and tap it into place with a mallet (**Fig. 7a**). Confirm the proper placement of the implant using fluoroscopy.

Once the implant is in the proper position, disengage and remove the inserter.

#### Distractor Inserter:

Introduce the Distractor Inserter into the prepared intervertebral space (**Fig. 7b**). Gradually rotate the T-handle clockwise to advance the implant. The keel on the instrument can be adjusted to rest the implant at 0, 2, and 4mm recessed from the anterior margin. Confirm the proper placement of the implant using fluoroscopy.

Once the implant is in the proper position, disengage and remove the Distractor Inserter.

#### Implant Positioning:

If the implant needs to be positioned further into the prepared space, gently tap the implant with the tamp provided in the instrument tray.

Verify final placement of the implant with fluoroscopic imaging.

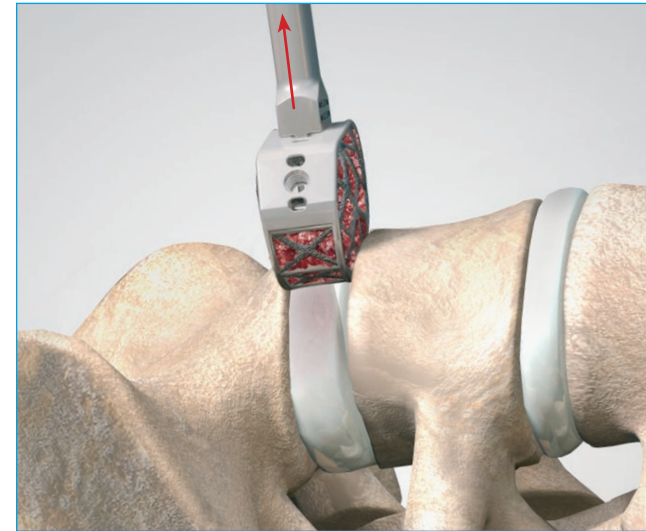

Fig. 8a

#### 8: IMPLANT REMOVAL

If implant removal is required, the intervertebral space should be distracted in the same manner as for implant placement. Once distracted, the implant may be removed by using the insertion tool (**Fig. 8a**).

The implant should be disengaged from the superior and inferior endplates with the surgeon's preferred technique. The surgeon should apply slight back-pressure in order to remove the implant.

If greater force is required, use the slap hammer provided in the instrument tray to remove the implant (**Fig. 8b**).

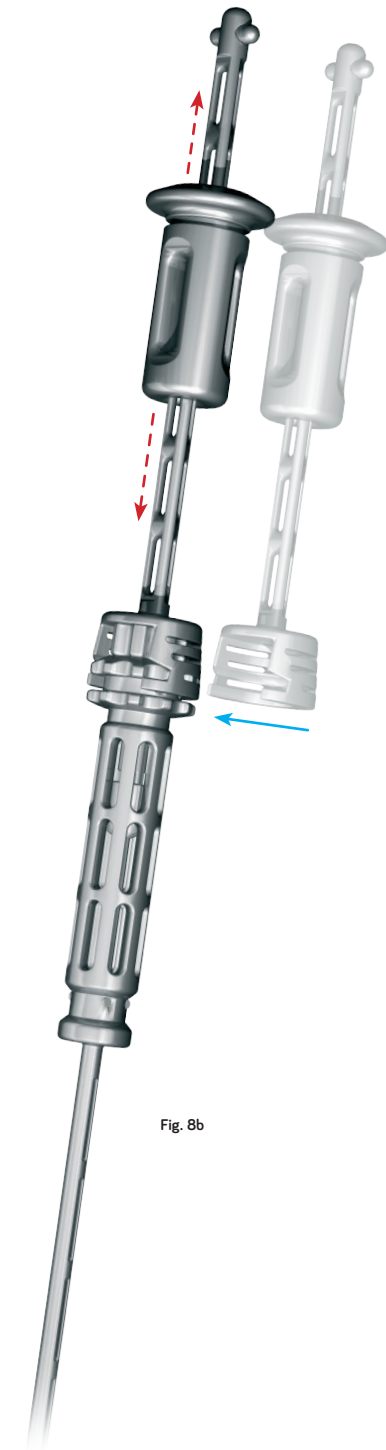
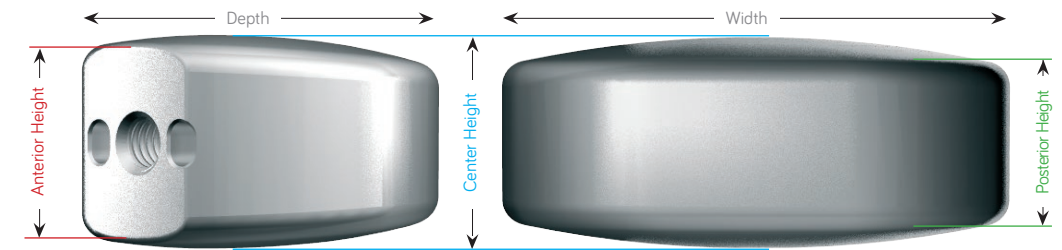
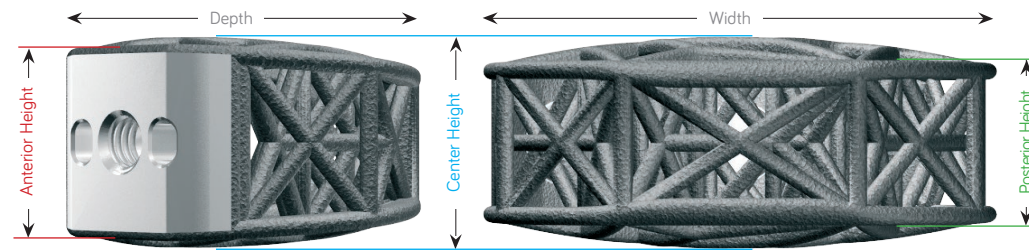

Fig. 8b



**ASTS IMPLANTS - 21 X 32mm (SM) - 6 DEGREE:**

Part Number	Anterior Height (mm)	Center Height (mm)	Posterior Height (mm)	Graft Volume (cc)
ASTS-SM0608-SP	8.0	10.5	5.9	2.85
ASTS-SM0610-SP	10.0	12.5	7.9	3.83
ASTS-SM0612-SP	12.0	14.5	9.9	4.80
ASTS-SM0614-SP	14.0	16.5	11.9	5.77
ASTS-SM0616-SP	16.0	18.5	13.9	6.74

**ASTS IMPLANTS - 21 X 32mm (SM) - 12 DEGREE:**

Part Number	Anterior Height (mm)	Center Height (mm)	Posterior Height (mm)	Graft Volume (cc)
ASTS-SM1208-SP	8.0	9.4	3.8	2.33
ASTS-SM1210-SP	10.0	11.4	5.8	3.29
ASTS-SM1212-SP	12.0	13.4	7.8	4.26
ASTS-SM1214-SP	14.0	15.4	9.8	5.23
ASTS-SM1216-SP	16.0	17.4	11.8	6.20

**ASTS SIZER (SM) - 21 X 32mm - 6 DEGREE:**

Part Number	Size (mm)
ASTS-SM0608-S	8.0
ASTS-SM0610-S	10.0
ASTS-SM0612-S	12.0
ASTS-SM0614-S	14.0
ASTS-SM0616-S	16.0

**ASTS SIZER (SM) - 21 X 32mm - 12 DEGREE:**

Part Number	Size (mm)
ASTS-SM1208-S	8.0
ASTS-SM1210-S	10.0
ASTS-SM1212-S	12.0
ASTS-SM1214-S	14.0
ASTS-SM1216-S	16.0

**ASTS IMPLANTS - 24 X 36mm (MD) - 6 DEGREE:**

Part Number	Anterior Height (mm)	Center Height (mm)	Posterior Height (mm)	Graft Volume (cc)
ASTS-MD0608-SP	8.0	10.8	5.6	4.10
ASTS-MD0610-SP	10.0	12.8	7.6	5.42
ASTS-MD0612-SP	12.0	14.8	9.6	6.72
ASTS-MD0614-SP	14.0	16.8	11.6	8.01
ASTS-MD0616-SP	16.0	18.8	13.6	9.31

**ASTS IMPLANTS - 24 X 36mm (MD) - 12 DEGREE:**

Part Number	Anterior Height (mm)	Center Height (mm)	Posterior Height (mm)	Graft Volume (cc)
ASTS-MD1208-SP	8.0	9.5	3.2	3.31
ASTS-MD1210-SP	10.0	11.5	5.2	4.59
ASTS-MD1212-SP	12.0	13.5	7.2	5.89
ASTS-MD1214-SP	14.0	15.5	9.2	7.19
ASTS-MD1216-SP	16.0	17.5	11.2	8.49

**ASTS SIZER (MD) - 24 X 36mm - 6 DEGREE:**

Part Number	Size (mm)
ASTS-MD0608-S	8.0
ASTS-MD0610-S	10.0
ASTS-MD0612-S	12.0
ASTS-MD0614-S	14.0
ASTS-MD0616-S	16.0

**ASTS SIZER (MD) - 24 X 36mm - 12 DEGREE:**

Part Number	Size (mm)
ASTS-MD1208-S	8.0
ASTS-MD1210-S	10.0
ASTS-MD1212-S	12.0
ASTS-MD1214-S	14.0
ASTS-MD1216-S	16.0

**ASTS IMPLANTS - 27 X 40mm (LG) - 6 DEGREE:**

Part Number	Anterior Height (mm)	Center Height (mm)	Posterior Height (mm)	Graft Volume (cc)
ASTS-LG0608-SP	8.0	11.0	5.3	5.56
ASTS-LG0610-SP	10.0	13.0	7.3	7.25
ASTS-LG0612-SP	12.0	15.0	9.3	8.92
ASTS-LG0614-SP	14.0	17.0	11.3	10.59
ASTS-LG0616-SP	16.0	19.0	13.3	12.26

**ASTS IMPLANTS - 27 X 40mm (LG) - 12 DEGREE:**

Part Number	Anterior Height (mm)	Center Height (mm)	Posterior Height (mm)	Graft Volume (cc)
ASTS-LG1208-SP	8.0	9.7	2.6	4.39
ASTS-LG1210-SP	10.0	11.7	4.6	6.06
ASTS-LG1212-SP	12.0	13.7	6.6	7.72
ASTS-LG1214-SP	14.0	15.7	8.6	9.40
ASTS-LG1216-SP	16.0	17.7	10.6	11.06

**ASTS SIZER (LG) - 27 X 40mm - 6 DEGREE:**

Part Number	Size (mm)
ASTS-LG0608-S	8.0
ASTS-LG0610-S	10.0
ASTS-LG0612-S	12.0
ASTS-LG0614-S	14.0
ASTS-LG0616-S	16.0

**ASTS SIZER (LG) - 27 X 40mm - 12 DEGREE:**

Part Number	Size (mm)
ASTS-LG1208-S	8.0
ASTS-LG1210-S	10.0
ASTS-LG1212-S	12.0
ASTS-LG1214-S	14.0
ASTS-LG1216-S	16.0

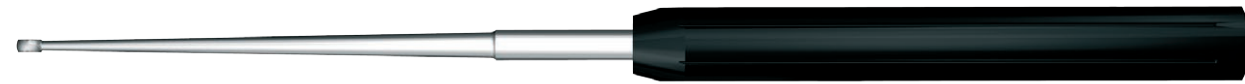

#3 STRAIGHT RING CURETTE - ASTS-000105  
#4 STRAIGHT RING CURETTE - ASTS-000106



#3 ANGLED RING CURETTE - ASTS-000100  
#4 ANGLED RING CURETTE - ASTS-000101



3/4 Inch (0.75") COBB ELEVATOR - ASTS-000700  
1 Inch (1.0") COBB ELEVATOR - ASTS-000701

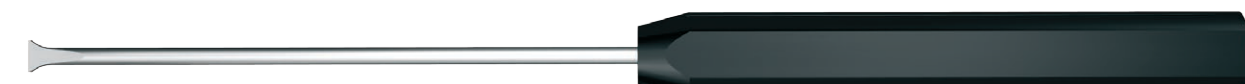

STRAIGHT TAMP - ASTS-000020



SINGLE-SIDED STRAIGHT RASP - ASTS-000401



4mm STRAIGHT RONGEUR - ASTS-000200

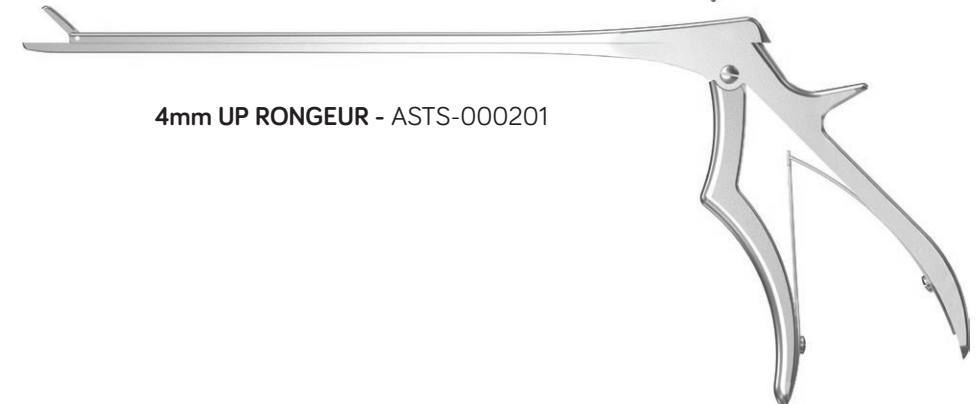

4mm UP RONGEUR - ASTS-000201

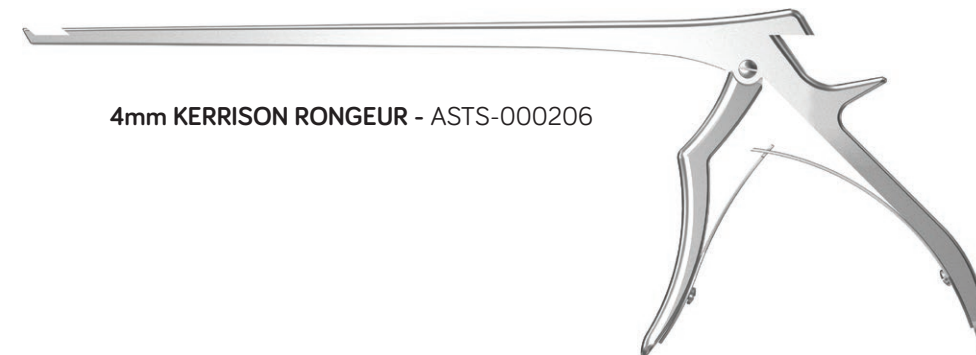

4mm KERRISON RONGEUR - ASTS-000206



12mm DOUBLE ACTION RONGEUR - ASTS-000202



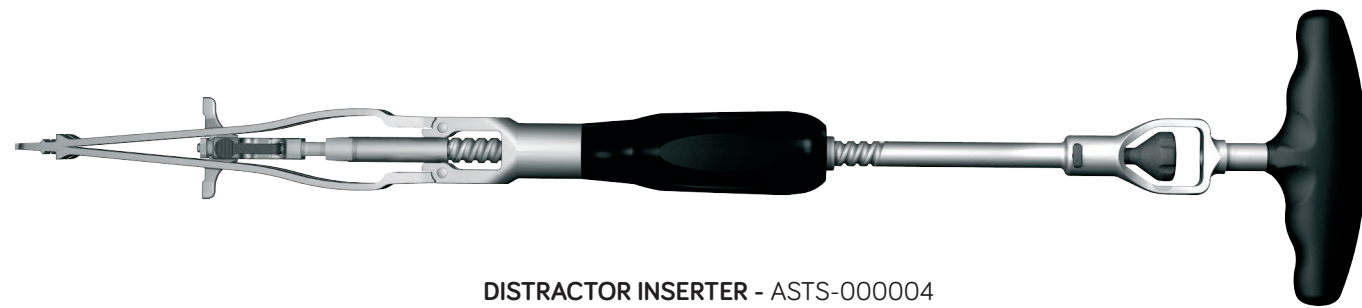

DISTRACTOR INSERTER - ASTS-000004



STRAIGHT INSERTER - ASTS-000007

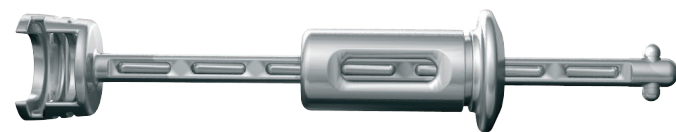

SLAP HAMMER - ASTS-000050

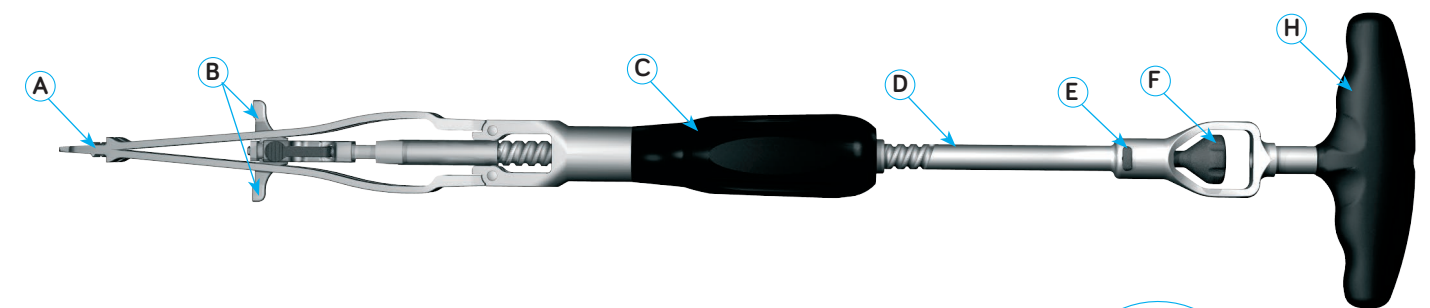

The Distractor Inserter is comprised of the following parts:

- A) Shims
- B) Keel
- C) Inserter body
- D) Threaded shaft
- E) Threaded shaft quick-release button
- F) Implant locking knob
- G) Inner shaft
- H) T-handle

**Instrument Disassembly:**

1. Press the quick-release button (E) located below the implant locking knob (Fig. 10) and pull the knob towards the T-handle to release and remove the locking knob from the inner shaft (Fig. 11).
2. Manually feed the inner shaft (G) through the cannulated T-handle out the proximal end of the instrument (Fig. 12).
3. Remove the keel (B) from the distal end of the threaded shaft by splaying the shims (Fig. 13).

**Instrument Reassembly:**

To reassemble follow the disassembly instructions in reverse order.

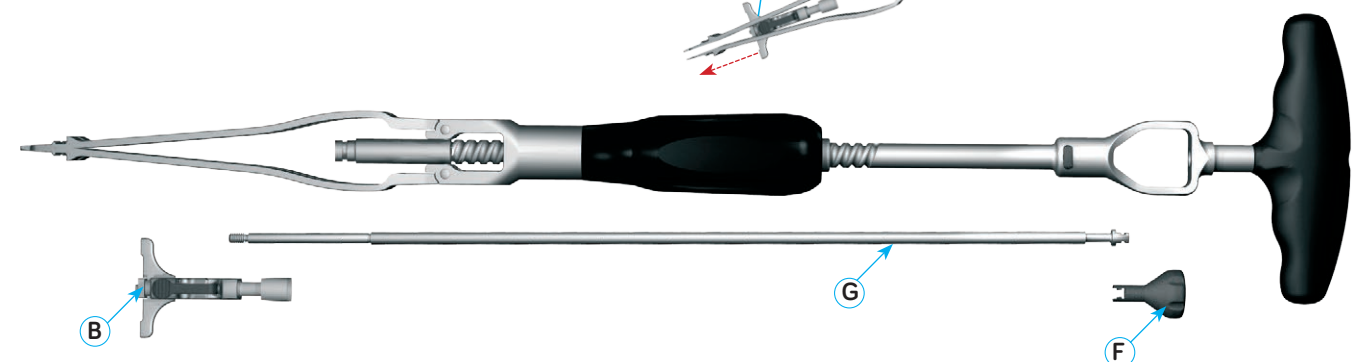
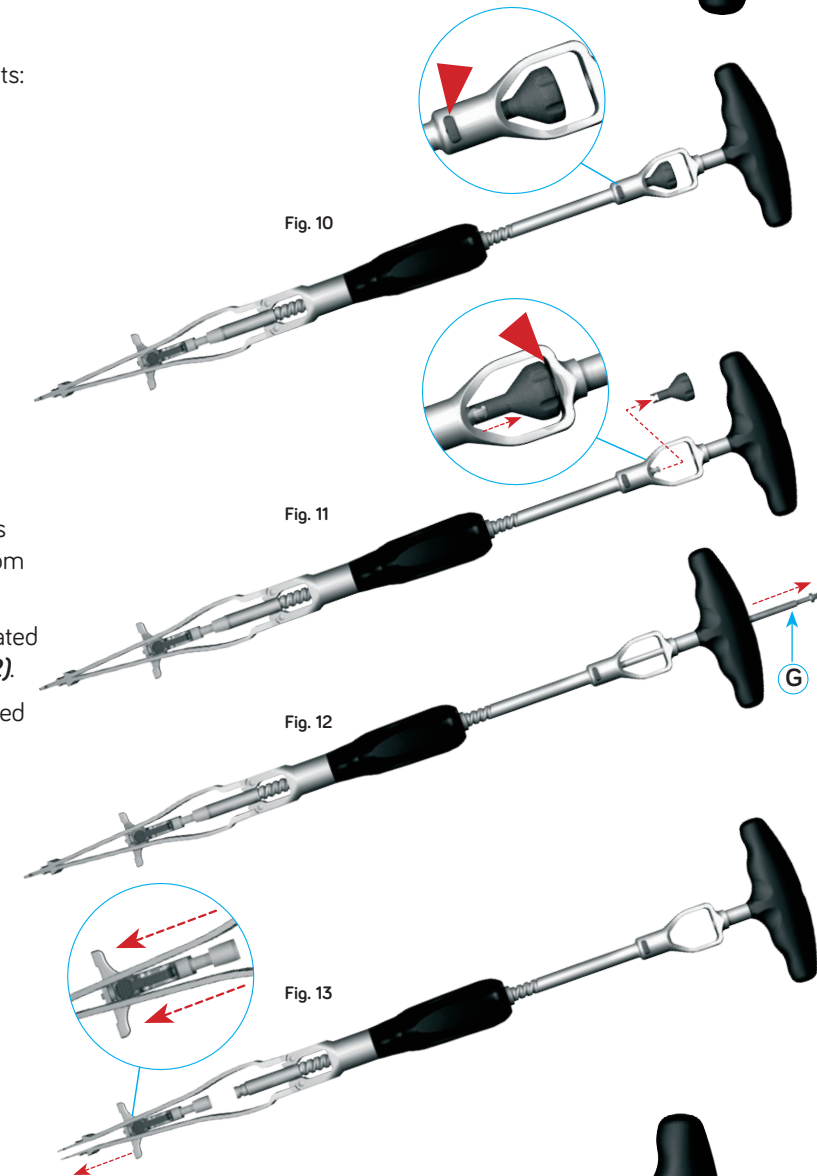







**4WEB MEDICAL**

6170 Research Road, Suite 219

Frisco, TX 75033

(800) 285-7090 | [4WEBMEDICAL.com](http://4WEBMEDICAL.com)

ST-ASTS-01 v2 01/17