



Surgical Technique

PYRENEES

Constrained & Translational

As Described By:

John P. Kostuik, MD
Co-Founder, Past Chairman & Chief Medical Officer – K2M, Inc.
Professor Emeritus – Johns Hopkins University, Orthopaedics & Neurosurgery
Past President – Scoliosis Research Society (SRS)
& North American Spine Society (NASS)



Surgical Technique

TABLE OF CONTENTS

Preface	1
Features & Benefits	2
SURGICAL TECHNIQUE STEPS	
STEP 1: Patient Positioning	4
STEP 2: Discectomy/Corpectomy	5
STEP 3: Plate Selection & Placement	6
STEP 4: Plate Contouring	8
STEP 5: Plate Introduction & Temporary Fixation	9
STEP 6: Drill Guides	11
STEP 7: Perforate Vertebral Body	14
STEP 8: Select Stop Drill	15
STEP 9: Drill Vertebral Body	16
STEP 10: Thread Former	17
STEP 11: Screw Selection/Tap Vertebral Body	18
STEP 12: Screw Insertion	20
STEP 13: Bone Reduction	22
STEP 14: Final Tightening	23
STEP 15: <i>ifix</i> ® Locking Technology	24
STEP 16: Clip Removal	26
STEP 17: Compression/Distracton	27
STEP 18: Radiograph	28
STEP 19: Screw or Plate Removal	29
STEP 20: Wound Closure	30
PRODUCT CATALOG	
Screws	32
Plates	33
Preparation & Placement Instruments	34
Screw Site Preparation Instruments	36
Drill Guides	38

Dear Colleagues,

Welcome to K2M and the PYRENEES® Cervical Plate Systems! With these breakthrough technologies, K2M strives to attain the highest level of excellence in the orthopaedic industry. The systems have been designed by surgeons and engineers with the ultimate objective of providing you with a revolutionary locking mechanism, requiring no additional locking step.

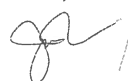
PYRENEES is named after a range of mountains in southwest Europe, forming a natural border between France and Spain. The systems incorporate the revolutionary *ifix*® Locking Technology, whereby each screw head forms an autogenic lock to the plate upon insertion.

The implant and instrument technology is state-of-the-art with several enhancing features to facilitate more efficient intraoperative use of the systems. The multidirectional screws can be inserted conically up to 30° and lock upon insertion. In addition, repeated screw adjustment or realignment up to three times can be achieved without compromising the locking feature. The Translational Plate allows for up to 2 mm of uni-directional translation at each level.

A significant investment has been made in the instrument design in an effort to provide you with multiple options during surgery. These designs incorporate several new and innovative ideas for simplifying surgical application of the implants.

The PYRENEES Cervical Plate Systems are, in my opinion, a step forward in the design of cervical plate systems for the treatment of our patients. The following surgical technique clearly outlines the procedural details and options and offers a reference to help explain the many features of these systems for use in treating patients as indicated.

Sincerely,



John P. Kostuik, MD

Co-Founder, Past Chairman, & Chief Scientific Officer – K2M, Inc.
Professor Emeritus – Johns Hopkins University, Orthopaedics & Neurosurgery
Past President – Scoliosis Research Society (SRS) & North American Spine Society (NASS)

FEATURES & BENEFITS

PYRENEES® Constrained Cervical Plate System



DRILL GUIDES

IMPLANTS

- Low Profile Cervical Plate with a Leading Edge of 1.7 mm & a Maximum 2.5 mm Profile
- Features the Revolutionary *ifix*® Locking Technology, Whereby Each Screw Head Forms an Autogenic Lock to the Plate Upon Insertion
- No Additional Locking Mechanism Required
- Multidirectional Screws Can be Inserted Conically up to 30° & Lock Upon Insertion
- Repeated Screw Adjustment or Realignment Without Compromising the Locking Feature
- 1 – 5 Level Color-coded Plates
- Screw Sizes of 4.0 mm Diameter; Self-tapping & Self-starting, Ranging From 12 – 16 mm Lengths
- Rescue Screws of 4.35 & 4.5 mm Diameter
- Color-coded Screws by Length for Easy Intraoperative Identification

GENERATION 2 INSTRUMENTATION

- Upgraded Instrumentation to Include Silicone Handles & Streamlined AO Connections on All Handles
- Modular Trays for More Streamlined Ordering
- Newly Designed Drill Guides, Including the FAST Drill Guide & Fast Awl
- New Plate Bender with Rotating Anvil to Create a Shallow or Deep Bend for Any Plate Length
- Thread Former Allows for up to 45° of Conical Angulation
- Color-coded Drills to Match Screw Lengths

PYRENEES® Translational Cervical Plate System



DRILL GUIDES

IMPLANTS

- Uni-directional Translational Plates
- Ratchets 2 mm per Level in 1 mm Increments
- Revolutionary *ifix*® Locking Technology
- Flexibility to Insert Screws Conically up to 30°
- Screws Lock to the Plate Upon Insertion, No Additional Locking Mechanism Needed
- 1 – 4 Level Color-coded Plates
- Screw Sizes of 4.0 mm Diameter; Self-Tapping & Self-Starting, Ranging From 12 to 16 mm Lengths
- Rescue Screws of 4.35 & 4.5 mm Diameter
- Color-coded Screws by Length for Easy Intraoperative Identification

INSTRUMENTATION

- Modular Trays for More Streamlined Ordering
- 4 Available Drill Guides: Fixed & Variable Drill Guides, Screw-Thru Fixed Drill Guide, & a FAST Drill Guide
- Color-coded Tips Identify Translational Instrumentation

STEP

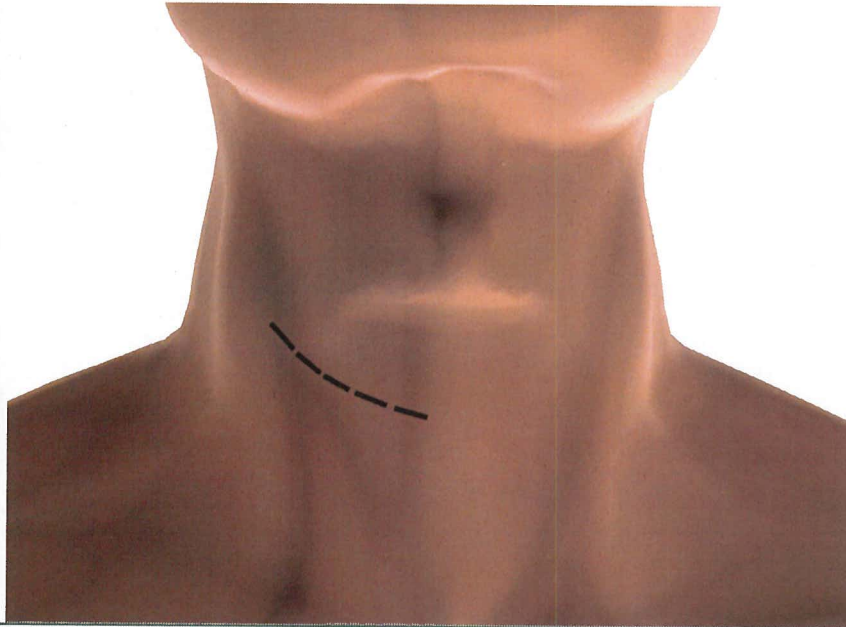
Surgical Technique Steps

PYRENEES® Cervical Plate Systems

STEP

1

2



4

5

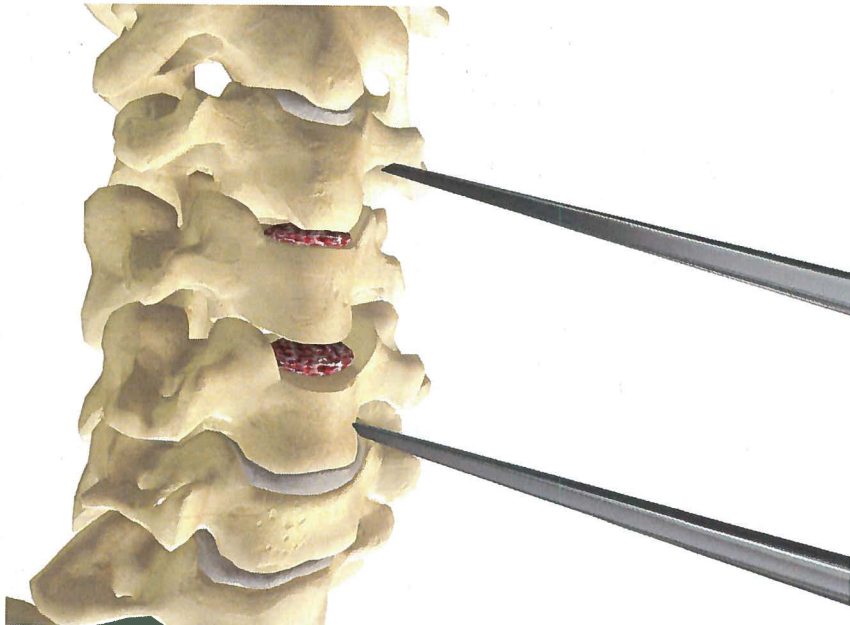
**PATIENT POSITIONING
& VERTEBRAL BODY
PREPARATION**

Position the patient in the supine position. Perform a standard incision and exposure of the ventral, cervical spine. Confirm the surgical level with X-ray or fluoroscopy.

**DISCECTOMY/
CORPECTOMY**

Perform the discectomy or corpectomy with grafting, as indicated for the patient. Remove all osteophytes from the anterior surface of the vertebrae to allow the plate to sit flush against the vertebral bodies.

3



PYRENEES CONSTRAINED

PYRENEES TRANSLATIONAL



PYRENEES Cervical Plate	Lengths*
1 Level	18 – 36 mm
2 Level	34 – 54 mm
3 Level	48 – 78 mm
4 Level	61 – 101 mm
5 Level	95 – 110 mm

PYRENEES Cervical Plate	Lengths*
1 Level	23 – 37 mm
2 Level	38 – 52 mm
3 Level	53 – 71 mm
4 Level	68 – 92 mm

PLATE SELECTION & PLACEMENT

Select the correct plate and screw lengths to best fit the application. The appropriate plate size can be determined by placing the distal tips of the Caliper on the vertebral bodies at the anticipated overall plate length. The appropriate plate size is the closest to the indicated length for the number of levels being fused.

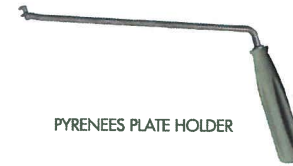
Be sure the plate does not extend over the adjacent disc spaces. A properly sized plate will allow access to both screw holes at each end of the plate.

*Some plate lengths are available by request

4

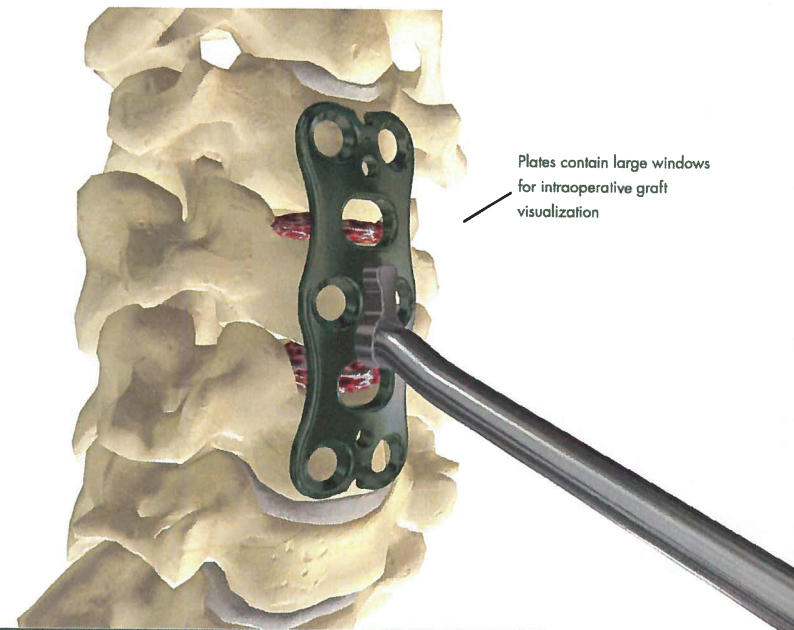


PLATE BENDER



PYRENEES PLATE HOLDER

5



Plates contain large windows
for intraoperative graft
visualization

8

PLATE CONTOURING

NOTE: This step is for PYRENEES Constrained only

Plates are designed with lordotic curvature to minimize intra-operative contouring. A Plate Bender is available to further contour the plate to better match the patient's anatomy. The Plate Bender may be used to add additional lordosis or kyphosis to the plate. All

plates can be bent anatomically without impairing the ability of the screws to lock at any angle, ultimately eliminating bend zones.

NOTE: DO NOT bend Translational Plates. Bending may cause damage to the translational feature.

PLATE INTRODUCTION & "OPTIONAL STEP" TEMPORARY FIXATION

Use the PYRENEES Plate Holder (available by request) or any of the Screw-Thru Drill Guides to place the cervical plate into the wound. If using the Screw-Thru Drill Guides, the two locating pins on the bottom of the Drill Guide provide positive fixation to the plate.

9

5



TEMPORARY FIXATION PIN HOLDER



TEMPORARY FIXATION PIN

6



FIXED DRILL GUIDE

VARIABLE DRILL GUIDE

FIXED SCREW-THRU
DRILL GUIDEVARIABLE SCREW-THRU
DRILL GUIDE

FAST DRILL GUIDE

10

PLATE INTRODUCTION & "OPTIONAL STEP" TEMPORARY FIXATION (CONT.)

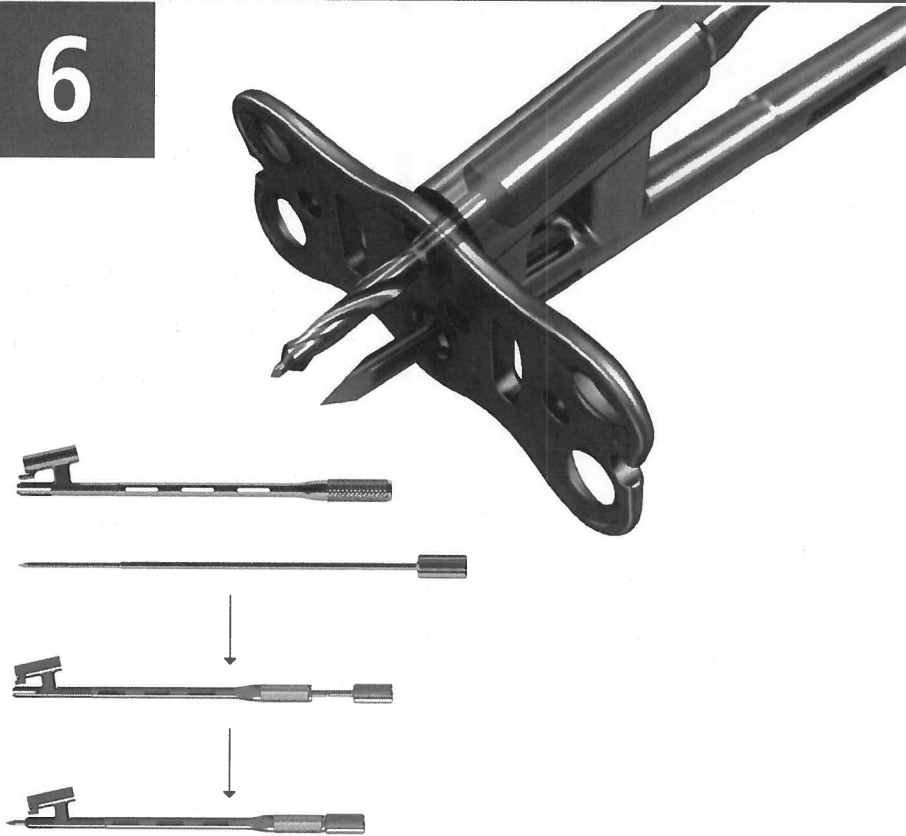
After the plate has been positioned on the anterior cervical spine, Temporary Fixation Pins may be used to temporarily secure the plate to the vertebra. Pull back on the shaft of the Temporary Fixation Pin Holder to engage the pin and, once seated, the Temporary Fixation Pin Holder can be disengaged from the Temporary Fixation Pin. Temporary Pins may be inserted via the screw holes or pins holes on the cephalad and caudal ends of the plate.

DRILL GUIDES

Five drill guides are available for use: a Fixed Drill Guide, a Variable Drill Guide, a Fixed Screw-Thru Drill Guide, a Variable Screw-Thru Drill Guide, and a Fast Drill Guide. All Drill Guides, except the Variable Screw-Thru Drill Guide, are available for both PYRENEES Constrained and PYRENEES Translational. The Variable Screw-Thru Drill Guide is only available for PYRENEES Constrained. The Translational Drill Guides are annodized gold at the tip.

11

6

VARIABLE
SCREW-THRU
DRILL GUIDEFIXED
SCREW-THRU
DRILL GUIDE

FIXED DRILL GUIDE

VARIABLE DRILL GUIDE

FAST DRILL GUIDE

12

**DRILL GUIDES
(CONT.)**

The FAST Drill Guide, in conjunction with the FAST Awl, provides a screw-thru option. To use the FAST Drill Guide, insert the FAST Awl down the shaft of the Drill Guide. Align the guide in two adjacent screw holes on the plate.

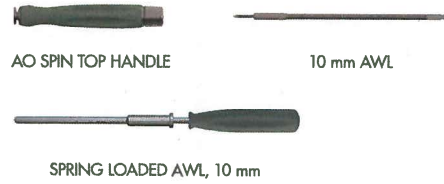
13

DRILL GUIDES

The Fixed Screw-Thru Drill Guide can be used to tap, drill and insert screws at a fixed trajectory of 12° and, along with the Variable Screw-Thru Drill Guide, provides a positive docking onto the plate. The Variable Screw-Thru Drill Guide provides the surgeon with 30° conical range of motion to tap, drill, and insert screws. The Fixed and

Variable Drill Guides have slim barrels to allow for improved visualization. The Variable Drill Guide provides 30° conical range of motion used to drill.

7

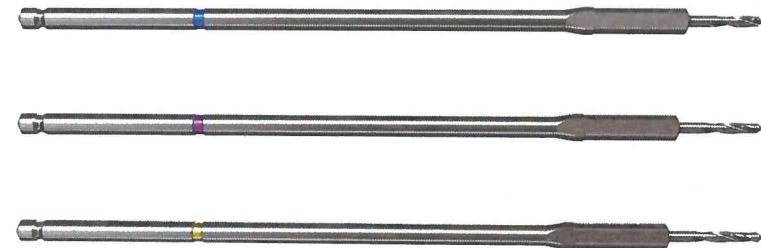


14

"OPTIONAL STEP"
PERFORATE VERTEBRAL BODY

If preferred, the 10 mm Spring Loaded Awl or the 10 mm Awl may be used to perforate the vertebral body. Insert the 10 mm Awl into the AO Spin Top Handle and Awl through the chosen Drill Guide.

8



15

SELECT STOP DRILL

Insert the selected Stop Drill (12, 14, or 16 mm) into the AO Spin Top Handle. These Drills are color-coded to match the screw colors.

9



AO SPIN TOP HANDLE



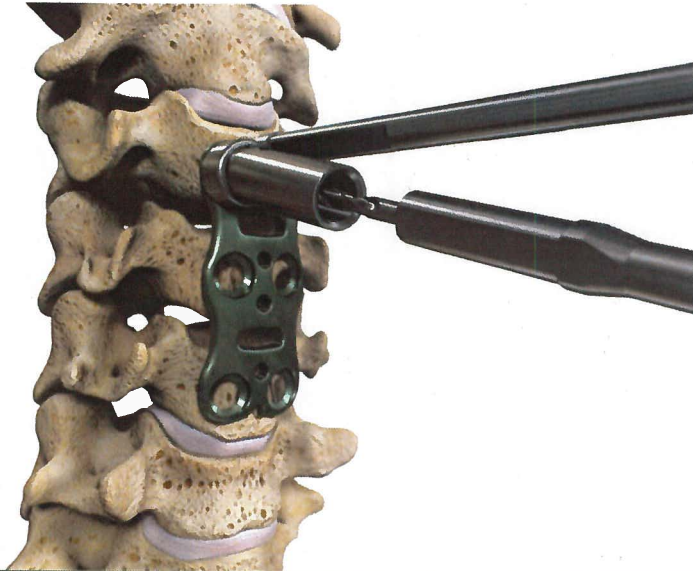
2.3 mm STOP DRILL, 12 mm (Color-coded)



2.3 mm STOP DRILL, 14 mm (Color-coded)



2.3 mm STOP DRILL, 16 mm (Color-coded)



THREAD FORMER



AO SPIN TOP HANDLE

10



16

DRILL VERTEBRAL BODY

Insert the selected Stop Drill (12, 14, or 16 mm) into the AO Spint Top Handle.

Drill the screw hole through the Drill Guide of choice. The FAST Drill Guide, in conjunction with the FAST Awl, provides a screw-thru option.

The Fixed Screw-Thru Drill Guide can insert screws at a fixed trajectory of 12°, the Variable Screw-Thru Drill

Guide provides 30° conical range of motion to insert screws, and the Variable Drill Guide provides 30° conical range of motion.

**“OPTIONAL STEP”
THREAD FORMER**

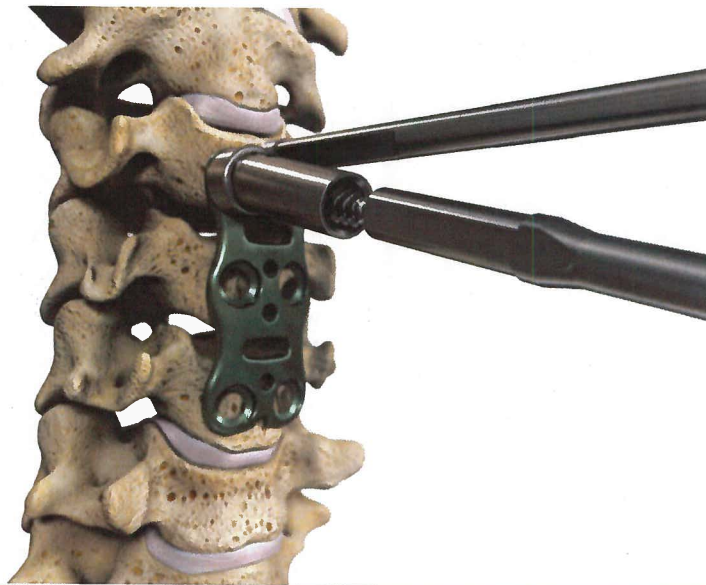
NOTE: This step is for PYRENEES Constrained only and is NOT INTENDED FOR USE ON TRANSLATIONAL PLATES.

If even greater angles must be obtained past 30°, the Thread Former may be used. This device prepares the plate to permit 45° conical angulation. After drilling the appropriate length, insert the Thread Former (up to 22.5° in any direction) to prepare a pathway

through the plate to accept the bone screw. Use of the Thread Former will help the screw sit flush in the plate.

17

11



SELF-STARTING SCREWS



SELF-TAPPING SCREWS



SCREW SELECTION/
TAP VERTEBRAL BODY

The PYRENEES Screws are color-coded by length for easy intraoperative identification and are available in three diameters, 4.0 (available in self-starting and self-tapping options), 4.35 and 4.5 mm. While the screws provided are self-tapping, the Ø2.3 mm Tap 10 mm or the Ø2.3 mm Tap

with Stop 10 mm may be inserted into the pilot hole at the same angulation it was drilled to tap the vertebral bodies. The Taps provided have a positive stop at 10 mm.

Both the Taps have a positive stop at 10 mm. If preferred, self-starting screws may be used, which do not require any drilling or tapping.



SIZE 10 TAPERED DRIVER



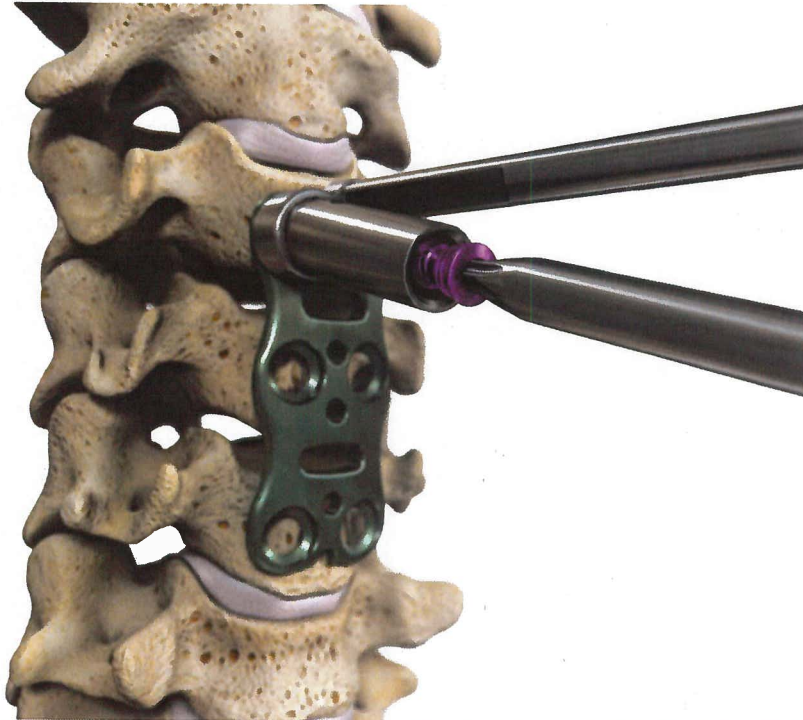
AO SPIN TOP HANDLE



SIZE 10 TAPERED DRIVER



AO SPIN TOP HANDLE

**SCREW INSERTION**

Insert the *ifix*® Bone Screws through the plate using the Size 10 Tapered Driver and tighten the bone screw until it begins to engage the plate. The Size 10 Tapered Driver has a tapered, self-holding tip (stab and grab) to aid in insertion of the PYRENEES Screws.

Repeat this procedure for the remaining screws.

13



4.0 X 14 mm BONE REDUCTION SCREW



TEMPORARY FIXATION PIN HOLDER



ANTI-TORQUE

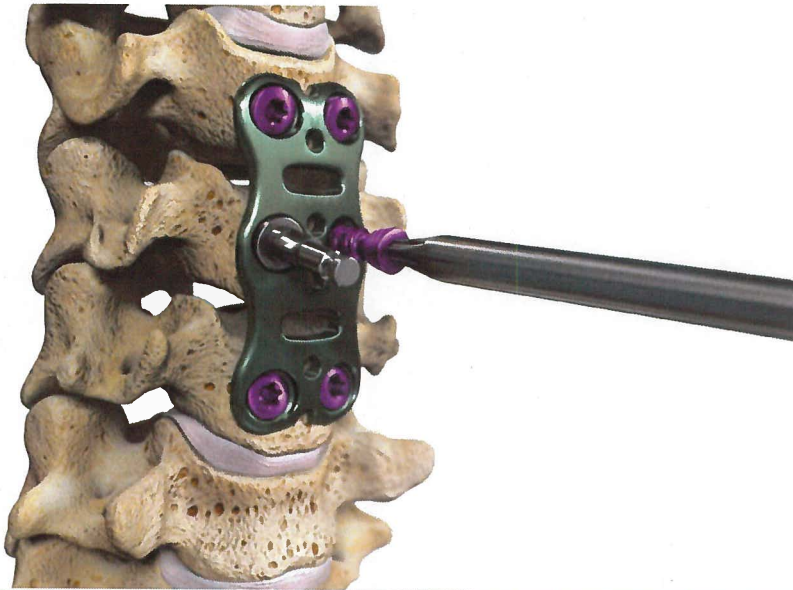


TORQUE LIMITING HANDLE



SIZE 10 NON-TAPERED TORQUE DRIVER

14



22

“OPTIONAL STEP” BONE REDUCTION

In cases where additional bone-lagging is required, a Bone Reduction Screw can be used to draw the vertebral body closer to the plate. A contralateral *ifix* Bone Screw should then be inserted to hold the vertebral body to the plate. Replace the Bone Reduction Screw with a *ifix* Bone Screw.



23

FINAL TIGHTENING

After all the *ifix* Bone Screws have been secured, utilize the Torque Limiting Handle in conjunction with the Torque Limiting Hexalobe Shaft for final tightening of the bone screws. The Torque Limiting Screwdriver will provide a locking torque of 20 in-lbs (2.26 Nm) and ensure the *ifix* Locking Technology

is fully engaged and not over tightened. The Anti-Torque instrument is available for both PYRENEES Constrained and Translational. This instrument docks onto the plate and is used as an Anti-Torque device when final tightening.

15



SIZE 10 NON-TAPERED TORQUE DRIVER



TORQUE LIMITING HANDLE



24

tifix® LOCKING TECHNOLOGY

Upon advancement of the screw, the screw head engages on the locking lip of the plate, lagging the plate down to the bone. Once bone lagging is complete, the revolutionary *tifix* Locking Technology commences.

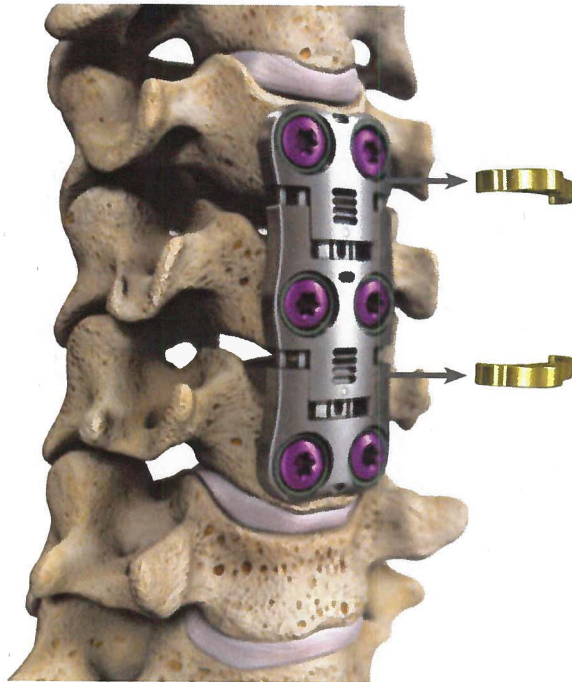
Due to a difference in material hardness and design, each screw head begins to reshape the screw hole and forms an autogenic lock to the plate upon insertion. With *tifix*, no additional locking is required.



25

Realignment of a screw can be repeated up to three times without compromising the locking feature.

16



26

CLIP REMOVAL

NOTE: This step is for PYRENEES Translational only

If using the translational plate, once the screws are locked into position, remove the pre-assembled clips at each level using standard OR forceps. Ensure ALL clips are removed before closing. The clips are single use items and, once removed, should be disposed.

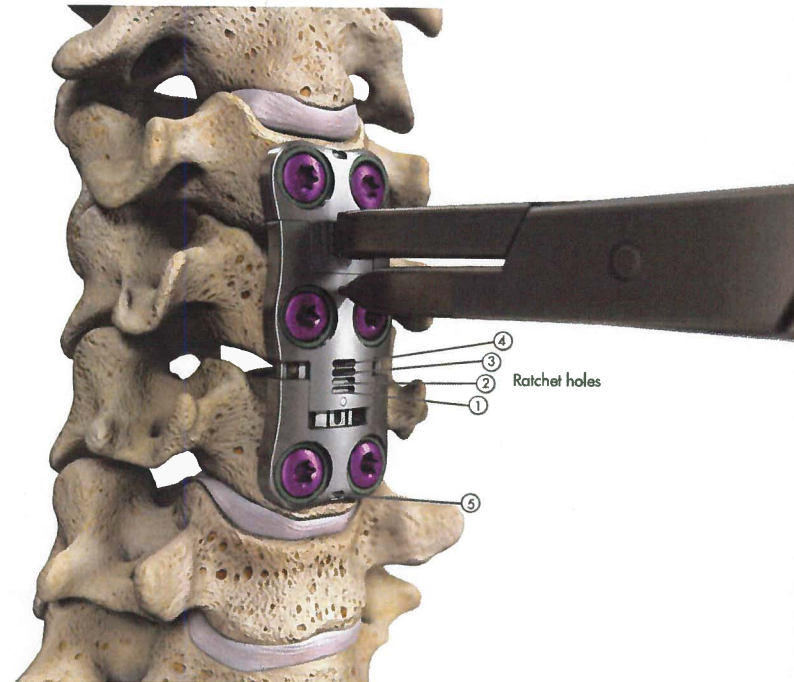
NOTE: The Translational Plates come pre-assembled with Titanium Alloy Clips that keep the plate extended in its maximum

open position during insertion. The standard Clips are 2 mm long. Prior to or post screw insertion, the 2 mm Clips may be replaced with 1 mm Clips, which allows the plate to be compressed when using a Compressor. Once the desired plate height is achieved and all screws have been inserted and final tightened, the 1 and/or 2 mm Clips must be removed from the plate. Should further compression be desired, the Compressor may again be used to fully compress the plate.



COMPRESSOR

DISTRACTOR



Ratchet holes

27

**COMPRESSION/
DISTRACTION**

NOTE: This step is for PYRENEES Translational only

If in-situ compression is preferred once the screws have been inserted and final tightened and the 1 or 2 mm clips have been removed, align the distal teeth of the Compressor in the ratchet holes 1, 2, and 3, then place the adjacent end of the Compressor in the notch across the level of compression, 5. Put light, downward pressure on the Compressor, and squeeze to collapse the plate. Once the plate is collapsed, it will not reopen

without use of a Distractor. The Distractor may be used in the same manner as the Compressor. With all clips removed, align the distal teeth of the Distractor in ratchet holes 2, 3, and 4, and place the adjacent end of the Distractor in the notch across the level of distraction, 5. Put light, downward pressure on the Distractor, and squeeze to distract the plate open.

18

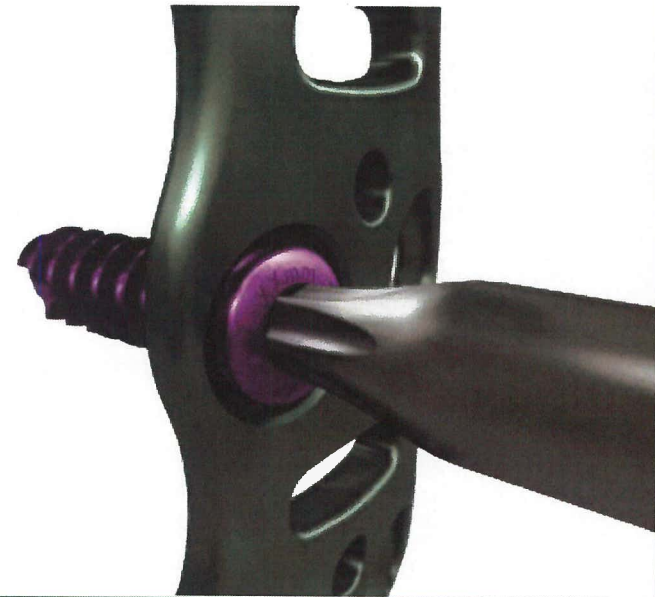


28

RADIOGRAPH

Obtain intraoperative radiographs to verify screw placement.

19



29

**SCREW OR PLATE
REMOVAL**

If a screw needs to be removed, re-engage the Size 10 Driver onto the head of the screw to disengage the screw from the plate. The screw can be locked and unlocked up to three times before replacing the plate.

If the plate needs to be removed, first unlock all screws, then proceed to remove all screws from the vertebral bodies.

STEP

Surgical Technique Steps

20



30

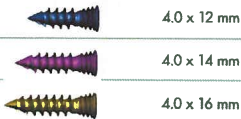
WOUND CLOSURE

Perform a standard multi-layer wound closure.

PYRENEES® CONSTRAINED
AND TRANSLATIONAL
PRODUCT CATALOG

31

SELF-STARTING SCREWS



SELF-TAPPING SCREWS



BONE REDUCTION SCREWS



CONSTRAINED PLATES



LENGTHS (mm) 18, 20, 22, 24, 26, 28, 30, 32, 34, 36

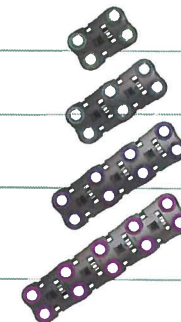
LENGTHS (mm) 36, 38, 40, 42, 44, 46, 48, 50, 52, 54
34 mm available by request only

LENGTHS (mm) 54, 57, 60, 63, 66, 69, 72, 75, 78
48 & 51 mm available by request only

LENGTHS (mm) 69, 73, 77, 81, 85, 89, 93, 97, 101
Available by request only

LENGTHS (mm) 95, 100, 105, 110
Available by request only

TRANSLATIONAL PLATES



LENGTHS (mm) 23, 25, 27, 29, 31, 33, 35, 37

LENGTHS (mm) 38, 40, 42, 44, 46, 48, 50, 52

LENGTHS (mm) 53, 56, 59, 62, 65, 68, 71

LENGTHS (mm) 68, 72, 76, 80, 84, 88, 92
Available by request only

CERVICAL PLATES

Unique catalog numbers exist for each plate. Please contact your local sales consultant with any questions you may have about ordering the PYRENEES Cervical Plate Systems.

SELF-STARTING & SELF TAPPING SCREWS

DESCRIPTION	CATALOG NUMBER	DESCRIPTION	CATALOG NUMBER
4.0 x 12 mm Self-Starting Screw	201-14012D	4.35 x 14 mm Self-Tapping Screw	201-14314C
4.0 x 14 mm Self-Starting Screw	201-14014D	4.35 x 16 mm Self-Tapping Screw	201-14316C
4.0 x 16 mm Self-Starting Screw	201-14016D	4.5 x 12 mm Self-Tapping Screw	201-14512C
4.0 x 12 mm Self-Tapping Screw	201-14012C	4.5 x 14 mm Self-Tapping Screw	201-14514C
4.0 x 14 mm Self-Tapping Screw	201-14014C	4.0 x 12 mm Bone Reduction Screw	201-90061
4.0 x 16 mm Self-Tapping Screw	201-14016C	4.0 x 14 mm Bone Reduction Screw	201-90062
4.35 x 12 mm Self-Tapping Screw	201-14312C		



PYRENEES PLATE HOLDER



TEMPORARY FIXATION PIN HOLDER

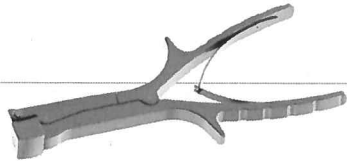
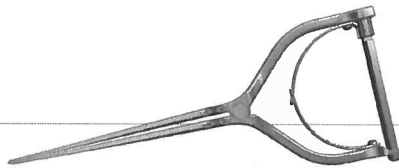


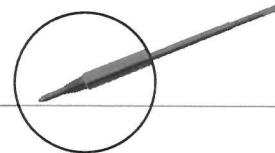
PLATE BENDER



TEMPORARY FIXATION PIN



CALIPER



AO CONNECT THREAD FORMER

PREPARATION & PLACEMENT

DESCRIPTION	CATALOG NUMBER
PYRENEES Plate Holder*	201-90029
Plate Bender	201-90148
Caliper	201-90035

*Available by request only

PREPARATION & PLACEMENT

DESCRIPTION	CATALOG NUMBER
Temporary Fixation Pin Holder	201-90111
Temporary Fixation Pin	201-90026
AO Connect Thread Former	201-90102

INSTRUMENTS



2.3 mm DRILL, 12 mm

2.3 mm DRILL, 14 mm

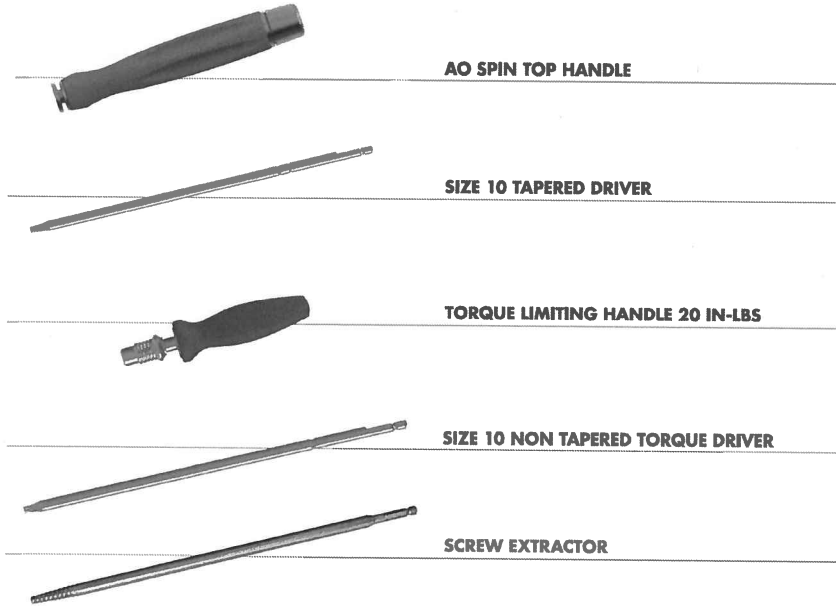
2.3 mm DRILL, 16 mm

10 mm AWL

Ø2.3 TAP, 10 mm

2.3 mm TAP, 10 mm WITH STOP TO PLATE

SPRING LOADED AWL, 10 mm



AO SPIN TOP HANDLE

SIZE 10 TAPERED DRIVER

TORQUE LIMITING HANDLE 20 IN-LBS

SIZE 10 NON TAPERED TORQUE DRIVER

SCREW EXTRACTOR

SCREW SITE PREPARATION

DESCRIPTION	CATALOG NUMBER	DESCRIPTION	CATALOG NUMBER
2.3 mm Drill, 12 mm (Color-Coded)	201-90104	2.3 mm Tap, 10 mm	201-90116
2.3 mm Drill, 14 mm (Color-Coded)	201-90105	2.3 mm Tap, 10 mm with Stop to Plate	201-90117
2.3 mm Drill, 16 mm (Color-Coded)	201-90106	Spring Loaded Awl, 10 mm	201-90122
10 mm Awl	201-90115		

DESCRIPTION	CATALOG NUMBER
AO Spin Top Handle	201-90173
Size 10 Tapered Driver	201-90118
Torque Limiting Handle 20 in-lbs	201-90140
Size 10 Non-Tapered Torque Driver	201-90133
Screw Extractor	201-90120



FIXED DRILL GUIDE

FIXED SCREW-THRU DRILL GUIDE

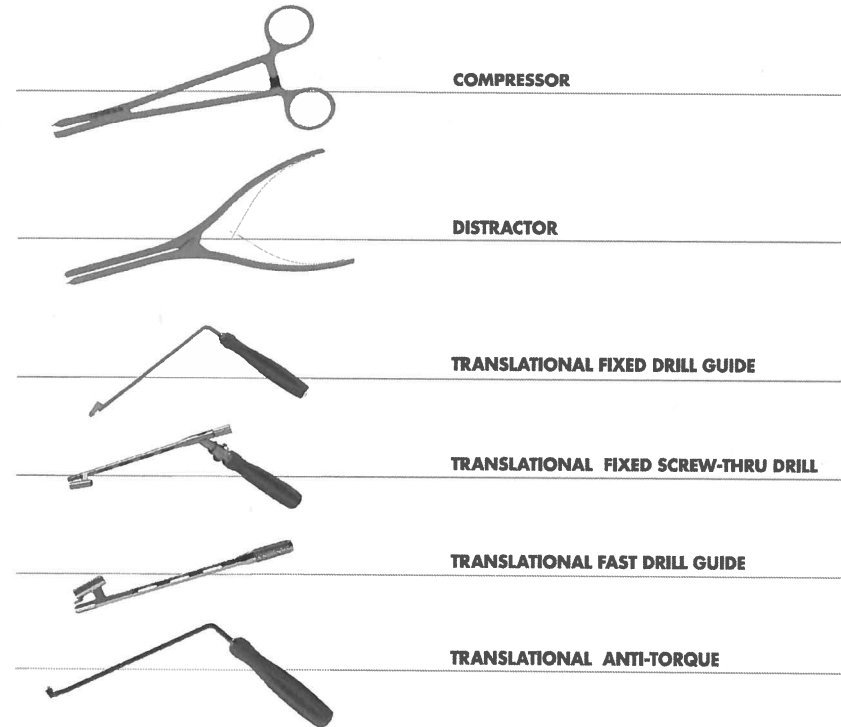
VARIABLE SCREW-THRU DRILL GUIDE

VARIABLE DRILL GUIDE

FAST DRILL GUIDE

FAST AWL

ANTI-TORQUE



COMPRESSOR

DISTRACTOR

TRANSLATIONAL FIXED DRILL GUIDE

TRANSLATIONAL FIXED SCREW-THRU DRILL

TRANSLATIONAL FAST DRILL GUIDE

TRANSLATIONAL ANTI-TORQUE

DRILL GUIDES

DESCRIPTION	CATALOG NUMBER
Fixed Drill Guide	201-90100
Fixed Screw-Thru Drill Guide	201-90176
Variable Screw-Thru Drill Guide	201-90101
Translational Variable Drill Guide	201-90099
FAST Awl	201-90177
Anti-Torque	201-90259

DESCRIPTION	CATALOG NUMBER
Compressor	201-90254
Distractor	201-90253
Translational Anti-Torque	201-90250
Translational Fixed Drill Guide	201-90185
Translational Fixed Screw-Thru Drill Guide	201-90252
Translational FAST Drill Guide	201-90251

Product Insert

BEFORE USING PRODUCT, READ THE FOLLOWING INFORMATION

IMPORTANT

This booklet is designed to assist in using the following: PYRENEES® and BLUE RIDGE® Cervical Plate Systems. It is not a reference for surgical techniques.

CAUTION: Federal law (USA) restricts this device to sale and use by, or on the order of, a physician.

DESCRIPTION

The PYRENEES Cervical Plates and screws are comprised of titanium alloy per ASTM F1472 and F136 and CP titanium per ASTM F67. The BLUE RIDGE Cervical Plates and screws are also made of titanium alloy and include a locking clip made of nitinol per ASTM F2063.

INDICATIONS

K2M Cervical Plate Systems are indicated for use in anterior screw fixation to the cervical spine (C2-C7) for the following indications: degenerative disc disease (DDD) (defined as neck pain of discogenic origin with degeneration of the disc confirmed by history and radiographic studies), spondylolisthesis, trauma (including fractures), spinal stenosis and tumors (primary and metastatic), failed previous fusions (pseudarthrosis) and deformity (defined as scoliosis, kyphosis or lordosis).

CLEANING/ REPROCESSING OF K2M SURGICAL INSTRUMENTS

K2M surgical instruments are supplied non-sterile and must be thoroughly cleaned prior to sterilization. While it is recommended that the following steps are included in a decontamination/ reprocessing protocol the end-user bears the ultimate responsibility for the cleanliness of the device. These instructions are not intended for K2M implants or disposable surgical instruments.

Contaminated instruments should be wiped clean of visible soil at the point of use, to prevent drying of soil and contaminants in and on the device.

Presoak the instruments with an enzymatic solution for a minimum of 5 minutes. Following the presoak the instruments should be wiped or scrubbed using a brush, cloth or sponge that does not mar the surface of the instrument. Remove soil from cannulated parts with a nylon bristle brush or appropriately sized guide wire. Rinse parts under water for one minute. Repeat the process until no visible debris remains. Clean K2M surgical instruments with an appropriate brush, cloth or sponge and low foaming, pH neutral detergent solution. The use of abrasive compounds or excessively acidic or alkaline solutions may cause damage to the instruments and should be avoided. Rinse parts under warm or hot flowing water for a minimum of 1 minute including direct contact with all surfaces for at least 10 seconds. Repeat rinsing step using distilled, reverse osmosis or deionized water. Automatic cleaning may be used in addition to manual cleaning. Do not ultrasonically clean torque limiting handles.

STERILIZATION

Packaged components are packaged individually in sealed poly bags. Unless specifically labeled sterile, the implants and instruments are supplied NON-STERILE and MUST be sterilized prior to use. Recommended sterilization methods include steam autoclaving after removal of all protective packaging and labeling. The following steam autoclave cycles were validated to an SAL of 10⁻⁶ using the biological indicator (BI) overkill method however sterilization should be in accordance with the sterilizer manufacturer's instructions and the institution's procedures for assuring sterility.

Autoclave Cycle		Temperature	Time	Drying Time
USA	Prevacuum	270° (132°C)	4 minutes	30 minutes
Outside USA	Prevacuum	273° (134°C)	3 minutes	30 minutes

Usage of an FDA cleared wrap to ensure that the device is actually sterile prior to implantation is recommended. Use caution during sterilization and storage. Do not allow contact with metal or other hard objects that could damage the finish or prevent proper use. (See Preoperative Warnings and Precautions).

NOTE: Instruments that may have been exposed to Creutzfeldt-Jakob disease (CJD) should be treated according to the hospital's prior decontamination protocol. K2M recommends contacting the Centers for Disease Control and the World Health Organization for the most recent information on CJD transmission and deactivation.

INSTRUCTIONS FOR USE

(For complete instructions refer to the appropriate surgical technique provided by your local K2M sales representative.)

The patient is placed in the position desired by the surgeon to allow a standard approach to the appropriate portion of the patient's anatomy for the procedure.

Following a standard approach to the patient's spine the appropriate implants are selected for screw fixation. Holding the plate with the plate holder, position it over the intended levels. Bend the plate as needed due to anatomical variations.

NOTE: Excessive reverse bending of Titanium plates can cause metal stressing resulting in a lower fatigue life for the plate.

Use the drill guides, awl, drills and taps to prepare the screw site. Select the proper size screw. Insert with the screw driver.

Use the fixation pins to hold the plate in place during screw preparation. Once the surgeon is satisfied the device has been properly implanted, the surgical site is closed in the usual manner.

CONTRAINDICATIONS

- These systems are contraindicated in the presence of infection, pregnancy, metabolic disorders of calcified tissues, grossly distorted anatomy, inadequate tissue coverage, drug/alcohol abuse, mental illness, general neurological conditions, immunosuppressive disorders, patients with known sensitivity to materials in the device, obesity, patients who are unwilling to restrict activities or follow medical advice, and any condition where the implants interfere with anatomical structures or precludes the benefit of spinal surgery.
- Biological factors such as smoking, use of nonsteroidal anti-inflammatory agents, the use of anticoagulants, etc. all have a negative effect on bony union. Contraindications may be relative or absolute and must be carefully weighed against the patient's entire evaluation.
- This device is not intended for use except as indicated.

POTENTIAL ADVERSE EVENTS

- Potential adverse events include, but are not limited to pseudoarthrosis; loosening, bending, cracking or fracture of components, or loss of fixation in the bone with possible neurologic damage, usually attributable to pseudoarthrosis, insufficient bone stock, excessive activity or lifting, or one or more of the factors listed in Contraindications, or Warnings and Precautions; infections possibly requiring removal of devices; palpable components, painful bursa, and/or pressure necrosis; and allergies, and other reactions to device materials which, although infrequent, should be considered, tested for (if appropriate), and ruled out preoperatively.
- Potential risks also include those associated with any spinal surgery resulting in neurological, cardiovascular, respiratory, gastrointestinal or reproductive compromise, or death.

WARNINGS AND PRECAUTIONS

- These systems are intended for use for the indications listed. Safety and effectiveness of the implants have not been established for other applications. The implants are for single use only and are not designed to be combined with devices from other manufacturers.
- For optimum results careful preoperative diagnosis and planning, meticulous surgical technique and extended postoperative care by experienced spinal surgeons are essential. Prior to use the surgeon should be specifically trained in the use of this spinal system and the

associated instrumentation to facilitate correct selection and placement of the implants. The size and shape of bones and soft tissue place limitations on the size and strength of the implants and proper selection will reduce the risk of neurological injury during implantation as well as metal fatigue leading to bending or breakage of the device.

- Patient selection and compliance is extremely important. Based on fatigue testing results, K2M Cervical Plate Systems have been determined to be substantially equivalent to predicate devices however when using these systems, the physician/surgeon should consider the levels of implantation, patient weight, patient activity level, other patient conditions, etc., which may impact the performance of these systems. Spinal implant surgery on patients with conditions listed under Contraindications may not be candidates for this procedure. The patient must be made aware of the limitations of the implant and that physical activity and load bearing have been implicated in premature loosening, bending or fracture of internal fixation devices. The patient should understand that an implant is not as strong as a normal, healthy bone and will fracture under normal load bearing in the absence of complete bone healing. An active, debilitated or uncooperative patient who cannot properly restrict activities may be at particular risk during postoperative rehabilitation.
- Potential risks identified with the use of this device system which may require additional surgery include device component failure, loss of fixation, non-union, fracture of the vertebra, and neurological, vascular or visceral injury.
- Cutting, bending, or scratching the surface of metal components can significantly reduce the strength and fatigue resistance of the implant system and should be avoided where possible. These, in turn may cause cracks and/or internal stresses that are not obvious to the eye and may lead to fracture of the components. Especially avoid sharp or reverse bends and notches.
- Special protection of implants and instruments during storage is recommended when exposed to corrosive environments such as moisture, salt, air, etc.
- Implanting metals and alloys in the human body subjects them to a constantly changing environment of salts, acids and alkalis which can cause corrosion. Putting dissimilar metals (e.g. titanium and stainless steel) in contact with each other can accelerate the corrosion process which in turn may enhance fatigue fractures of implants. Thus every effort should be made to use compatible metals and alloys. Fretting or wear at the interface between components of a device may also accelerate the corrosion process and may lead to the generation of wear debris which has been associated with localized inflammatory response.
- The implants are intended to provide temporary stabilization. If an implant remains implanted after complete healing it can actually increase the risk of refracture in an active individual. The surgeon should weigh the risks versus the benefits when deciding whether to remove the implant.
- This device has not been evaluated for safety and compatibility in the MR environment. This device has not been tested for heating or migration in the MR environment.

PREOPERATIVE

- The screws of this device system are not intended for insertion into the pedicles to facilitate spinal fusions.
- Patient conditions and/or predispositions such as those previously addressed in Contraindications and Warnings and Precautions should be avoided.
- Preoperative testing (simple bend and where necessary, stretch testing) should identify degree of correction possible without neurological damage and levels to be spanned using techniques similar to other spinal fusion procedures.
- Use care in handling and storage of the implants. Prior to surgery components should be inspected for any evidence of damage or corrosion.
- An adequate inventory of implant sizes should be available at the time of the surgery.
- All components should be cleaned and sterilized before use.

- Before the initial experience we recommend that the surgeon critically review all available information and consult with other surgeons having experience with the device.

OPERATIVE

- The primary goal of this surgery is to arthrodesis selected vertebrae. Adequate exposure, bony preparation and grafting are essential to achieving this result.
- Plates may be prebent to the degree of correction determined by preoperative testing however reverse bends should be avoided.
- The placement of screws should be checked radiographically prior to assembly of the rod construct.
- Care should be taken when positioning the implants to avoid neurological damage.
- Use of bone cement will make removal of the implants difficult and should be avoided.

POSTOPERATIVE

- Adequately instruct the patient. Postoperative care and the patient's ability and willingness to follow instructions are two of the most important aspects of successful healing.
- Internal fixation devices are load sharing devices which maintain alignment until healing occurs. If healing is delayed or does not occur the implant could eventually break, bend or loosen. Loads produced by load bearing and activity levels will impact the longevity of the implant.
- Implants can loosen, fracture, corrode, migrate, cause pain, or stress shield bone even after a bone has healed. If an implant remains implanted after complete healing, it can actually increase the risk of refracture in an active individual. The surgeon should weigh the risks versus benefits when deciding whether to remove the implant. Implant removal should be followed by adequate postoperative management to avoid refracture.
- Periodic X-rays for at least the first year postoperatively are recommended for close comparison with postoperative conditions to detect any evidence of changes in position, nonunion, loosening, and bending or cracking of components. With evidence of these conditions, patients should be closely observed, the possibilities of further deterioration evaluated, and the benefits of reduced activity and/or early revision considered.
- Surgical implants must never be reused. An explanted implant should never be reimplanted. Even though the device appears undamaged, it may have small imperfections and internal stress patterns which may lead to early breakage.

SYMBOL KEY

-  Caution: Consult Accompanying Documentation
-  Consult Instructions For Use
-  Do Not Reuse

PI008-0A11-00 Rev. 2
K2M Inc., 751 Miller Dr. SE
Leesburg, VA 20175
1.571.919.2000



K2M, Inc.

751 Miller Drive SE
Leesburg, Virginia 20175

USA PH 1.866.526.4171 • 1.571.919.2000
FX 1.866.862.4144



Emergo Europe

Molenstraat 15
2513 BH, The Hague
The Netherlands
PH +31.70.345.8570
FX +31.70.346.7299



www.k2m.com

©2015 K2M, Inc. All rights reserved.
K2027038.01 Rev. 2
Licensed from Prof. Dr. D. Woller
U.S. Patent 6,322,562
For Patent information please see
www.k2m.com/about-us/press
Actual device color may vary.
Consult product catalog for details.



0086

