

SYNFLATE™ VERTEBRAL BALLOON

Vertebral Augmentation System for
the reduction of fractures and/or
creation of a void in cancellous
bone in the spine

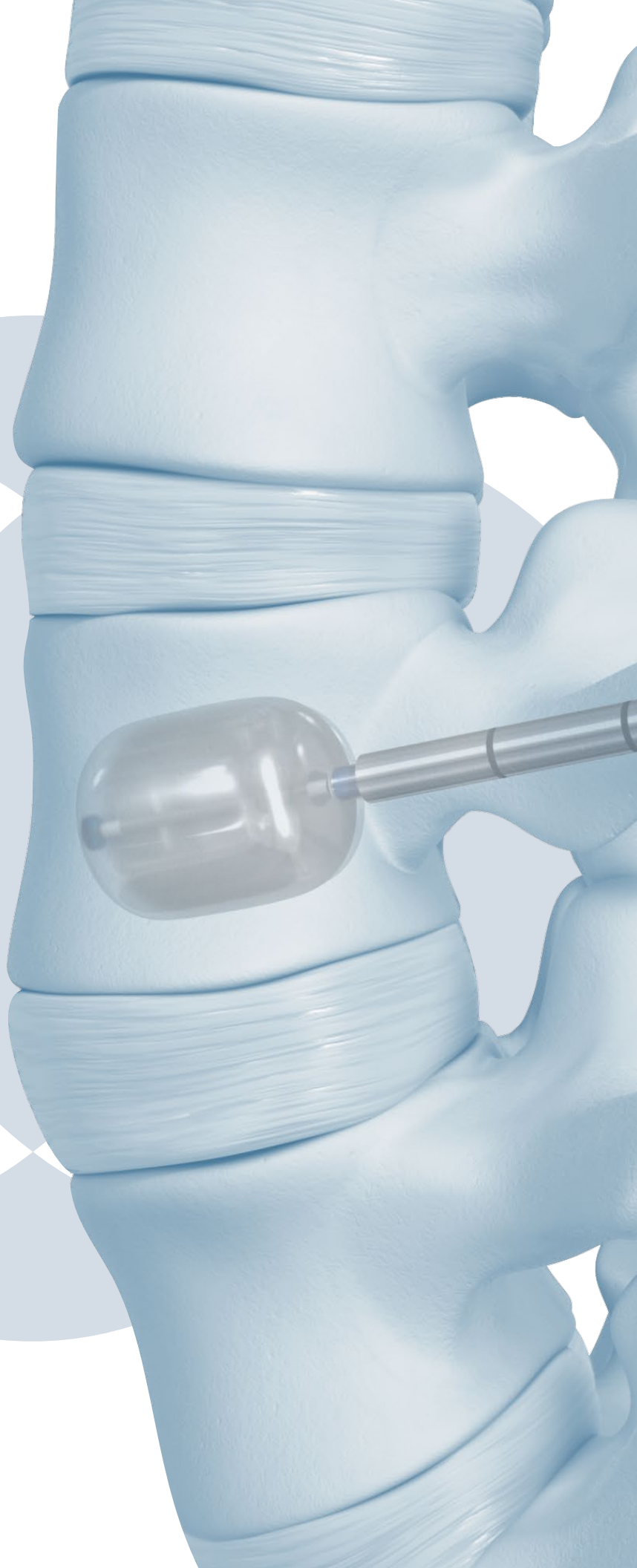

TABLE OF CONTENTS

INTRODUCTION	SYNFLATE™ Vertebral Balloon	2
	AO Principles	4
	Indications and Contraindications	5
	Product Selection	6
	Product Ordering	7
SURGICAL TECHNIQUE	Patient Positioning	8
	Surgical Technique	9
	Access	11
	Biopsy	12
	Create Channel and Determine the Balloon Size	13
	Preparation of Inflation System	15
	Preparation of SYNFLATE Vertebral Balloon	16
	Inflate the SYNFLATE Vertebral Balloon	18
	Deflate and Remove	21
	Inject PMMA Cement	22
	Postoperative Care	25
PRODUCT INFORMATION	Instruments	26

Warning

This description alone does not provide sufficient background for direct use of the instrument set. Instruction by a surgeon experienced in handling these instruments is highly recommended.

SYNFLATE™ VERTEBRAL BALLOON

Vertebral augmentation system for the reduction of fractures and/or creation of a void in cancellous bone in the spine

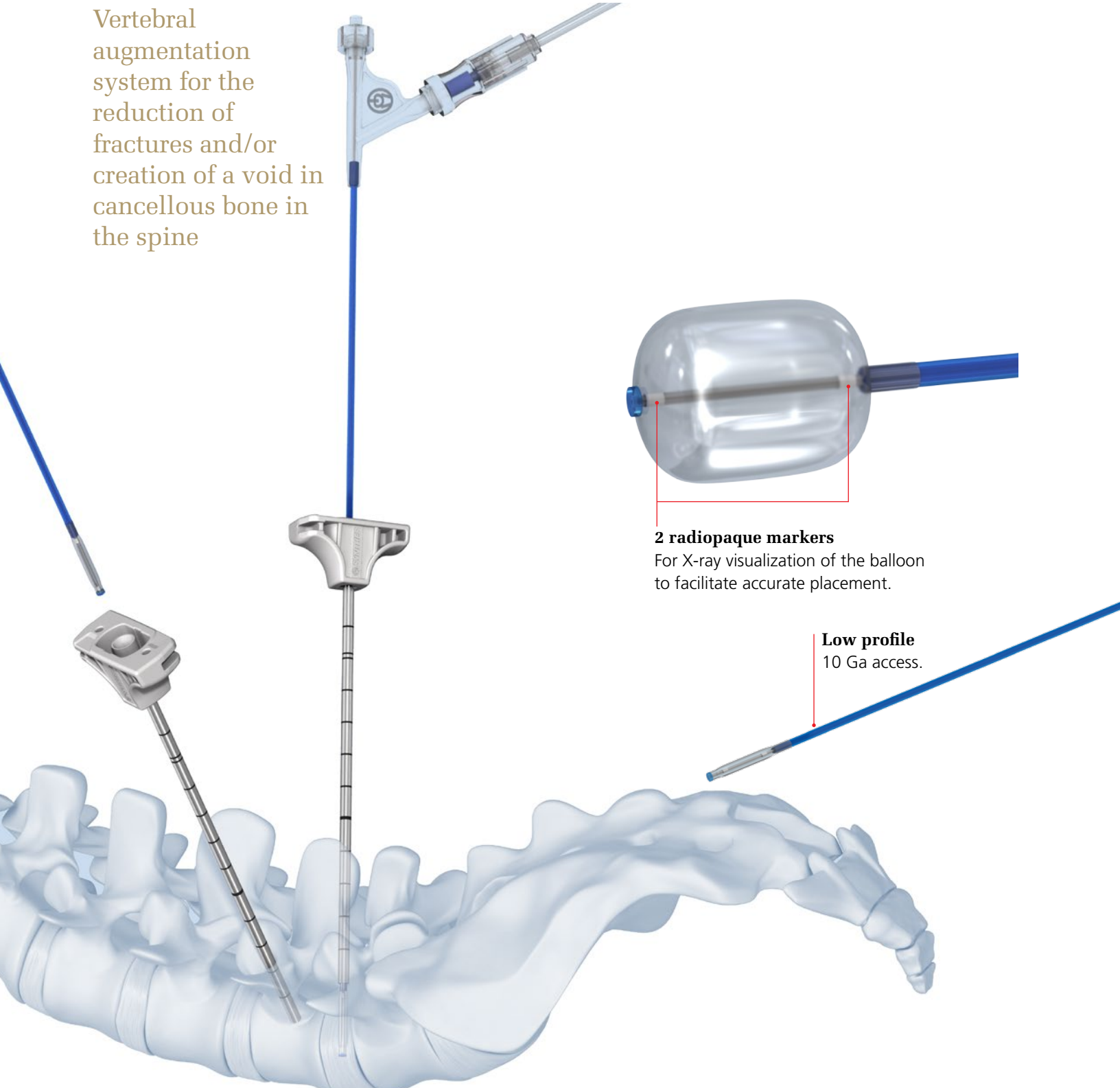

2 radiopaque markers
For X-ray visualization of the balloon to facilitate accurate placement.

Low profile
10 Ga access.

Insertion of the SYNFLATE Vertebral Balloon

Inflation port with valve
 One-step catheter preparation using the vacuum syringe enclosed in the packaging.

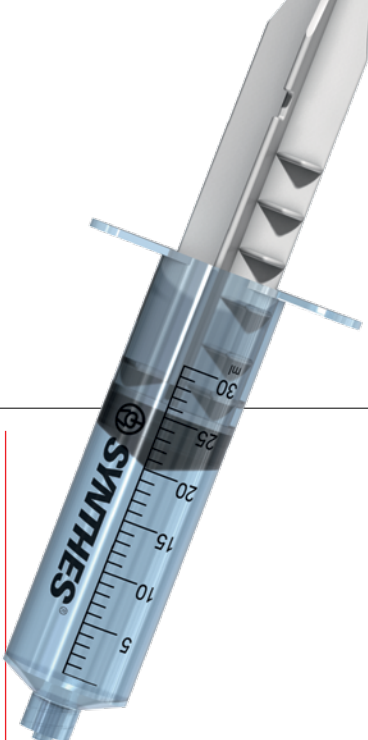

Shaft marker
 Helps to identify proper advancement into access cannula and vertebral body.

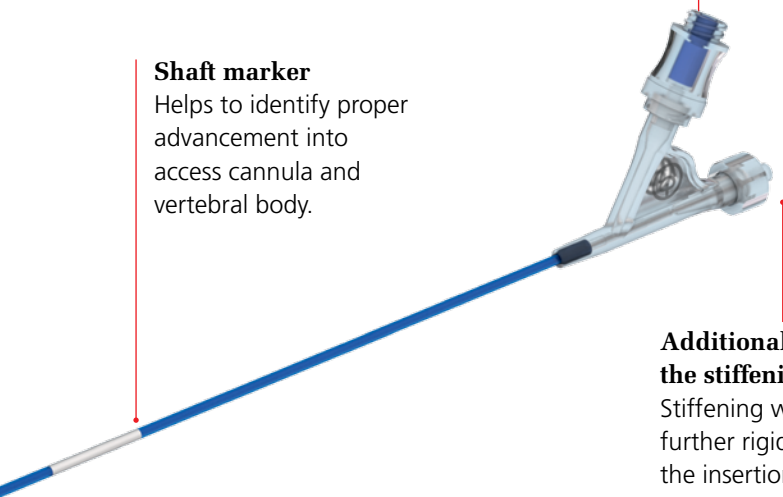

Additional port for the stiffening wire
 Stiffening wire offers further rigidity to facilitate the insertion of the thin catheter. The stiffening wire can be removed for inflation after insertion.

Different access trocars to suit physician preferences.

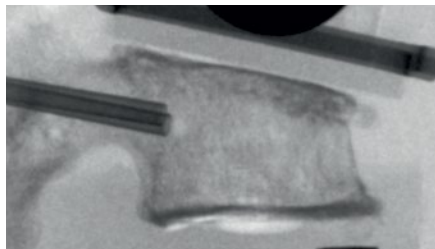

Access the Vertebral Body

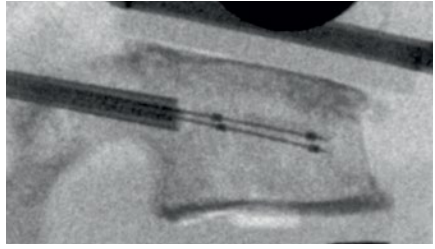

Insertion of the SYNFLATE Vertebral Balloon

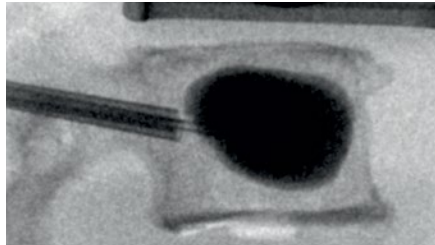

Inflation of SYNFLATE Vertebral Balloon

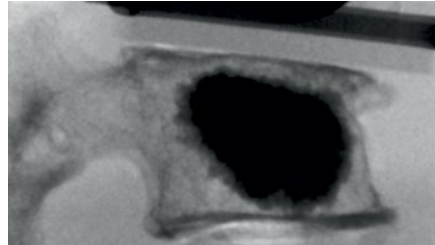

Injection of the bone cement

Small



Medium



Large



3 standard balloon sizes
 Covers a large anatomical range.

AO PRINCIPLES

In 1958, the AO formulated four basic principles, which have become the guidelines for internal fixation¹. They are:

- Anatomic reduction
- Stable fixation
- Preservation of blood supply
- Early, active mobilization

The fundamental aims of fracture treatment in the limbs and fusion of the spine are the same. But a specific goal of spine treatment is to restore as much function as possible to the injured neural elements.^{2,3}

1. Müller ME, Allgöwer M, Schneider R, Willenegger H: Manual of Internal Fixation, 3rd Edition. Berlin: Springer-Verlag. 1991.

2. Ibid.

3. Aebi M, Thalgott JS, Webb JK. AO ASIF Principles in Spine Surgery. Berlin: Springer-Verlag. 1998.

INDICATIONS AND CONTRAINDICATIONS

INDICATIONS

The SYNFLATE Vertebral Balloon System is intended to be used for the reduction of fractures and/or creation of a void in cancellous bone in the spine. This includes use during percutaneous vertebral augmentation. The system is to be used with cleared spinal polymethylmethacrylate (PMMA) bone cements indicated for use during percutaneous vertebral augmentation procedures, such as kyphoplasty.

CONTRAINDICATIONS:

- Instability of posterior wall and/or pedicles
- Systemic or local spinal infection
- Severe bleeding
- Known allergies to bone cement
- Pregnancy
- Fractures in which more than 75% of vertebral height is lost
- Any known severe allergy to contrast material
- When safe placement and inflation of the balloon is not possible due to vertebral dimensions or fracture pattern

Refer to the SYNFLATE System package insert for complete system information including descriptions, indications, contraindications, and warnings.

Refer to specific instructions for use of the cement being used for complete system specific information including indications, contraindications, warnings, precautions, and adverse reactions related to bone cement.

PRODUCT SELECTION

SYNFLATE VERTEBRAL BALLOON

The SYNFLATE™ Vertebral Balloon is available in three sizes.





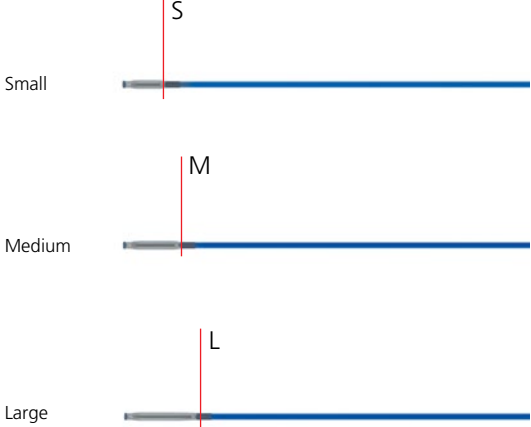

Product Number	Size	Length*
03.804.700S	Small	10 mm
03.804.701S	Medium	15 mm
03.804.702S	Large	20 mm

* Pre-inflated length



ACCESS KIT

The Access Kits are available in four configurations.

Product Number	Access Instrument Tip	Cement Injection Needle
03.804.517S		
03.804.518S		
03.804.519S		
03.804.520S		

The DePuy Synthes Spine SYNFLATE Vertebral Balloon is used as part of a modular system. All instruments and implants are purchased separately. This allows for maximum economy, flexibility, and precise surgical planning.

Below is a list of instruments available for this procedure:

Instruments

03.804.413S	Inflation System
03.804.517S	Access Kit, 10 Gauge, Diamond Tip/End Opening, Sterile
03.804.518S	Access Kit, 10 Gauge, Bevel Tip/End Opening, Sterile
03.804.519S	Access Kit, 10 Gauge, Diamond Tip/Side Opening, Sterile
03.804.520S	Access Kit, 10 Gauge, Bevel Tip/Side Opening, Sterile
03.804.521S	Access Drill, 10G, Sterile
03.804.522S	Biopsy Kit, 10G, Sterile
03.804.612S	Access Kit, Sterile
03.804.613S	Biopsy Kit, Sterile
03.804.700S	SYNFLATE Balloon Small, Sterile
03.804.701S	SYNFLATE Balloon Medium, Sterile
03.804.702S	SYNFLATE Balloon Large, Sterile

PATIENT POSITIONING

Position patient

Place the patient in the prone position on a radiolucent table to allow imaging of the targeted/affected levels (1).

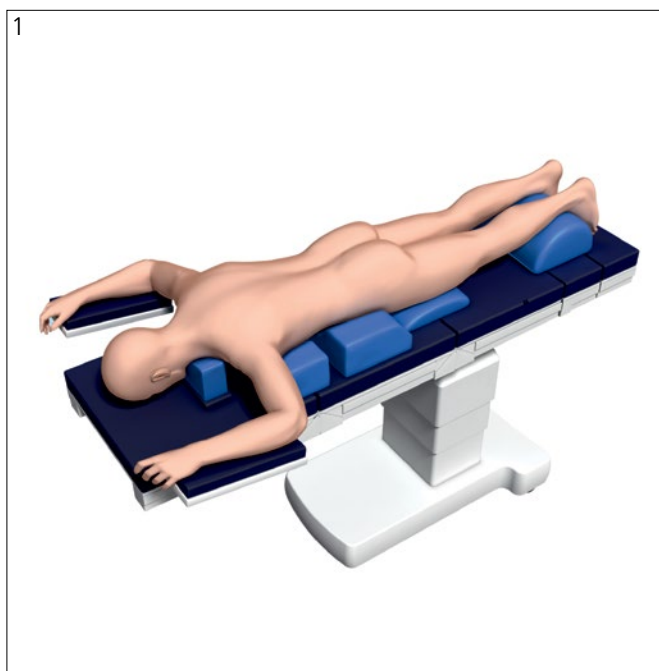

- AP and lateral fluoroscopy are used frequently throughout the procedure. Biplanar fluoroscopy is recommended for the most efficient use of imaging (2). A single, freely mobile C-arm may also be used. Use of a device that offers a high quality image is required. Set up the table, patient, and fluoroscopy to facilitate AP and lateral imaging throughout the procedure.

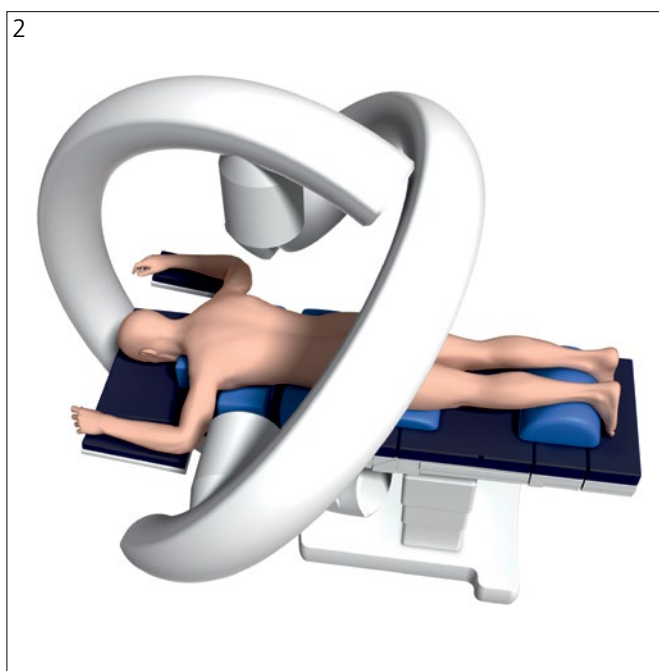

SURGICAL TECHNIQUE

1

Approach

Instrument options

03.804.517S	Access Kit, 10 Gauge, Diamond Tip/End Opening, Sterile
03.804.518S	Access Kit, 10 Gauge, Bevel Tip/End Opening, Sterile
03.804.519S	Access Kit, 10 Gauge, Diamond Tip/Side Opening, Sterile
03.804.520S	Access Kit, 10 Gauge, Bevel Tip/Side Opening, Sterile
03.804.521S	Access Drill, 10G, Sterile
03.804.612S	Access Kit, Sterile



Transpedicular approach

- The access instruments can be inserted through either a transpedicular or extrapedicular approach. Identify the anatomical landmarks of the affected segment(s) under imaging.

Option A: Transpedicular

- Under fluoroscopy, determine the location of the incision. The incision should facilitate insertion directly through the pedicle.

Important: Do not breach the pedicle wall or anterior cortical wall of the vertebral body during the approach.

Make a stab incision.

- Under fluoroscopy, insert the tip of the access instrumentation through the incision until it contacts the pedicle. Confirm the proper trajectory, then advance the instrumentation through the pedicle and into the vertebral body until the trocar tip is just past the posterior wall of the vertebral body.

Tip: Ensure that the tip of the access instrumentation does not pass the medial wall of the pedicle in the AP view until it has passed the posterior wall of the vertebral body in the lateral view to avoid entering the spinal canal.

Note: If considering a transpedicular approach, ensure that the diameter of the pedicle is large enough to accommodate the access instrumentation of 10 gauge (3.4 mm). If using Access Kit 03.804.612S, ensure that the diameter of the pedicle is at least 5.9 mm to accommodate access instruments with an outer diameter of 4.7 mm.

Option B: Extrapedicular

- ① Under fluoroscopy, determine the location of the incision. The access instruments should enter the vertebral body lateral to the pedicle.

Important: Do not breach the anterior cortical wall of the vertebral body during the approach.

Make a stab incision.

- ② Under fluoroscopy, insert the tip of the access instrumentation through the incision until it contacts the posterolateral border of the vertebral body. Confirm the proper trajectory, and then advance the instrumentation into the vertebral body until the trocar tip is just past the posterior wall of the vertebral body.

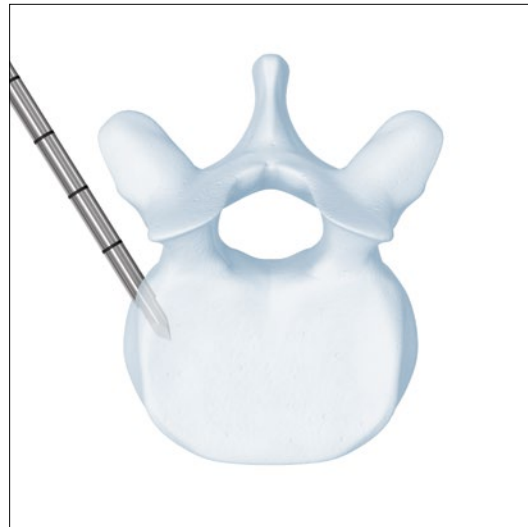

Extrapedicular approach

ACCESS

CREATE ACCESS

- 1 Under fluoroscopy, insert the access construct until the end of the working sleeve is positioned approximately 3 mm into the vertebral body (1). The end of the working sleeve can be viewed as a transition in diameter under fluoroscopy. For best visualization, temporarily slide the trocar out for fluoroscopic imaging. After imaging, slide the trocar fully forward into the working sleeve and lock into place to adjust positioning of the access instrumentation as necessary.

The access construct is marked with equidistant depth markers to allow monitoring of the insertion process. If necessary, carefully hammer on the blue handle of the trocar to gently advance the trocar instrumentation.

Precautions:

- **Ensure that the trocar instrumentation does not breach the anterior wall of the vertebral body.**
- **Only hammer on the blue handle of the access instrumentation. Do not hammer on the white plastic components.**

- 2 Confirm proper positioning of the access instrumentation under both AP and lateral fluoroscopy. Hold the working sleeve (white handle) in place and carefully rotate the trocar (blue handle) counterclockwise to unlock it from the working sleeve. Remove the trocar, leaving the working sleeve in the vertebral body (2).

For bilateral procedures, repeat on the contralateral side, prior to any balloon insertion.

Warnings:

- **Do not insert or advance the working sleeve in the bone without the trocar. This could damage the working sleeve and obstruct balloon insertion.**
- **Do not redirect the instrument assembly without removing it and re-accessing the vertebral body.**

Note: If Access Kit 03.804.612S is used, refer to the **Surgical Technique for the DePuy Synthes Spine Vertebral Body Balloon (VBB)** for complete instructions on guide wire and trocar access options.

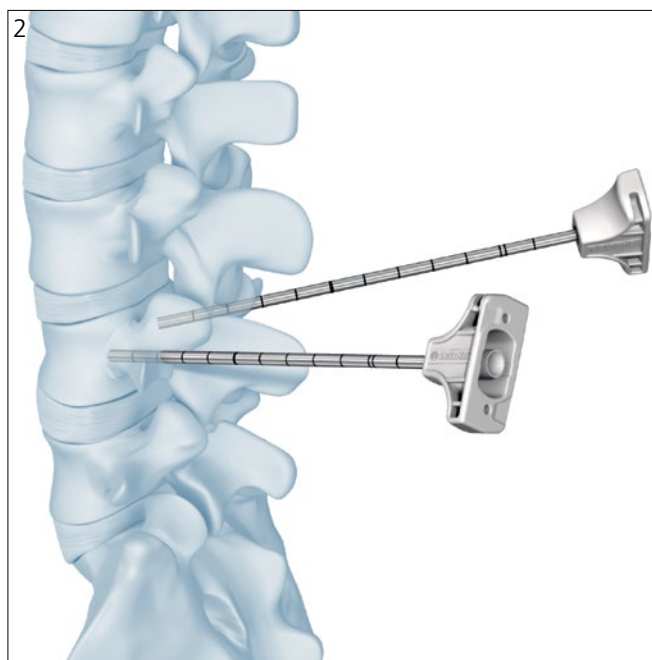

BIOPSY

After placement of the working sleeve an optional biopsy can be taken using the Biopsy Kit.

Instrument

03.804.522S Biopsy Kit, 10G, Sterile

03.804.613S Biopsy Kit, Sterile*

Remove plunger from biopsy needle.

- Under fluoroscopy insert biopsy needle into the working sleeve until the first marker reaches the shaft of the working sleeve (1). In this position, the tip of the biopsy needle is at the tip of the working sleeve.
- Under fluoroscopy, slowly advance the biopsy needle to the final position in the anterior half of the vertebral body. Do not use a hammer and take care not to perforate the anterior wall. Bone tissue will be captured in the biopsy needle.

Once the needle reaches the final position, rotate the biopsy needle one full turn (360°) to ensure that the bone biopsy is fully loosened from the surrounding bone.

Warning: Do not insert the biopsy needle beyond the anterior cortical wall of the vertebral body, as this could damage vascular structures.

Optionally, attach a standard Luer lock syringe to the biopsy needle (at least 3 cc) and slowly draw the syringe (2).

Remove the biopsy needle with the attached syringe (if used) from the working sleeve.

Note: Hold the working sleeve in place and carefully remove the biopsy needle leaving the working sleeve in the vertebral body.

If a syringe was used, remove it. Use the biopsy plunger to push the collected bone tissue out of the biopsy needle (3).

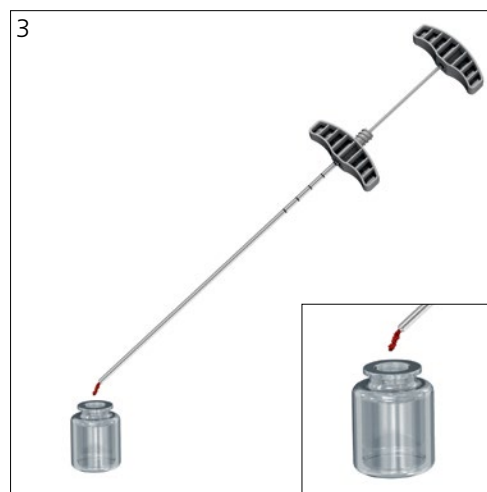
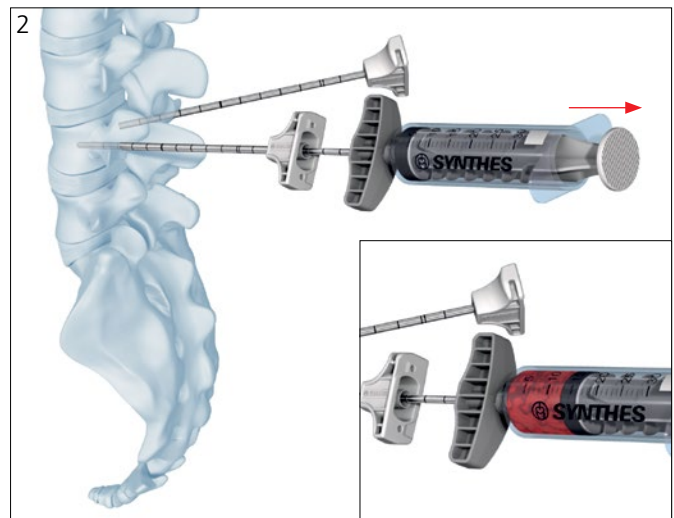
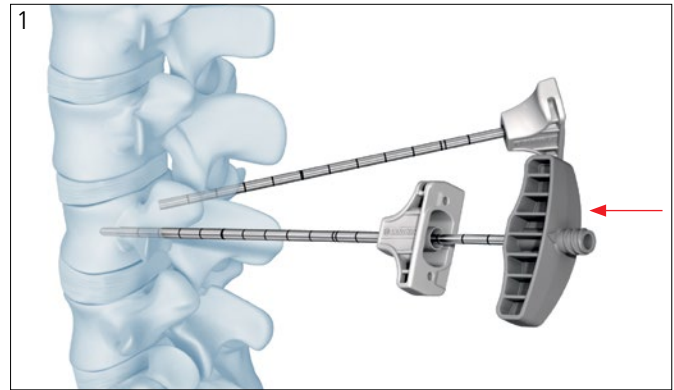

*Only if Access Kit 03.804.6125 is used for access creation.

CREATE CHANNEL AND DETERMINE THE BALLOON SIZE

The plunger has two important uses:

- Create an access channel for balloon insertion
- Determine the appropriate balloon size

CREATE CHANNEL

- 1 The access channel for the SYNFLATE Vertebral Balloon is created using the plunger.
- 2 Under lateral fluoroscopy, insert the plunger through the working sleeve and into the vertebral body. The plunger may be advanced by hand pressure or gently hammering on the blue handle (1).

Optionally, the plunger can be removed and the access channel created with the Access Drill. Advance the drill slowly by turning on the handle clockwise.

It is also possible to use the Access Drill prior to the use of the plunger.

Warning: Do not hammer on the drill.

Note: The distal (first) marking on the plunger/drill indicates when the tip leaves the working sleeve whereas the three following markers show the initial lengths of sizes S/M/L respectively.

- 3 **Warning: Always use fluoroscopy when advancing the drill or plunger. Do not insert the drill or plunger beyond the anterior cortical wall of the vertebral body, as this could damage vascular structures.**

Remove the drill and insert the plunger to size and verify balloon position.

Important: When inserting or removing the plunger or drill, ensure the working sleeve does not move.

For bilateral procedures, repeat on the contralateral side.

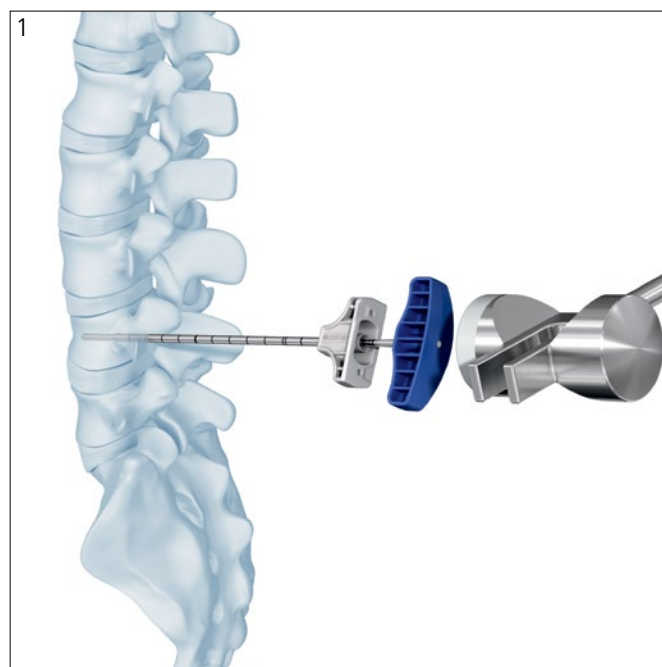
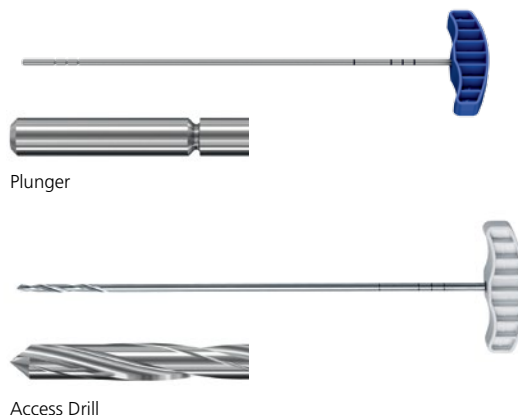

DETERMINE BALLOON SIZE

The SYNFLATE Vertebral Balloon is available in three sizes.

SYNFLATE Balloons, sterile

Article	Balloon Length	Maximum Diameter*	Maximum Length*
03.804.700S Small	10 mm	16.3 mm	18.1 mm
03.804.701S Medium	15 mm	16.1 mm	23.3 mm
03.804.702S Large	20 mm	16.3 mm	28.9 mm

Depending on the bony structure dimensions, diameter and length may vary inside the vertebral body.

The plunger has three grooves towards the distal tip that correspond to the three sizes of the SYNFLATE Vertebral Balloons: Small, Medium, and Large. An example of a Large size Balloon is shown (1, 2). Its pre-inflated length corresponds to the distance between tip and third groove of the plunger.

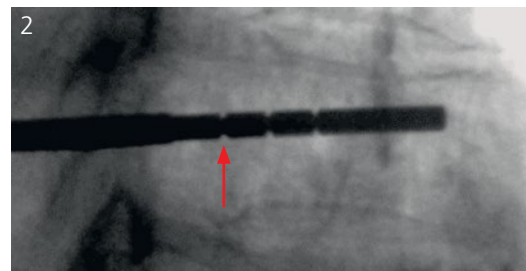
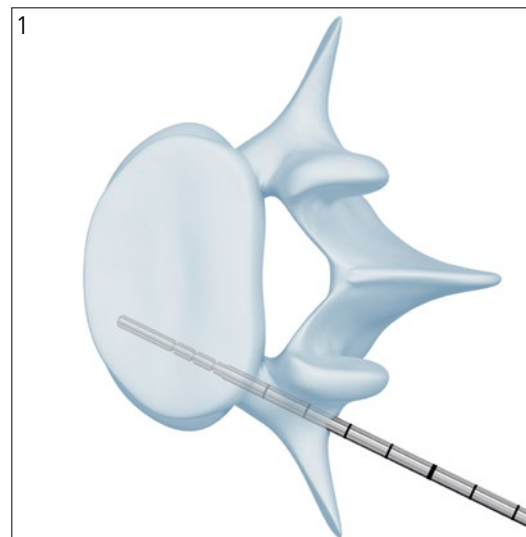
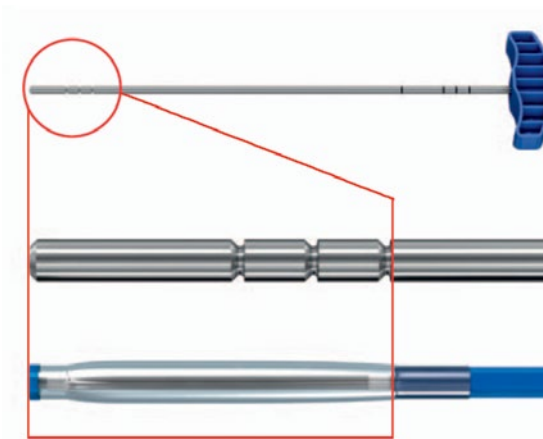

- Once the plunger has been positioned appropriately, use lateral fluoroscopy to determine the appropriate SYNFLATE Vertebral Balloon size**.

From distal tip, the first groove visible:
SYNFLATE Balloon, Small

From distal tip, the second groove visible:
SYNFLATE Balloon, Medium

From distal tip, the third groove visible:
SYNFLATE Balloon, Large

- Note: If no plunger grooves are visible under fluoroscopy, adjust the working sleeve and/or the plunger if possible. If the instrumentation cannot be safely adjusted to reveal at least one groove, then the SYNFLATE Vertebral Balloon procedure will not be possible and an alternative augmentation procedure should be employed.**

For bilateral procedures, repeat on the contralateral side.

Tip: When using two Single Packs for bilateral procedures two plungers are available which can be used simultaneously on both sides.

*At maximum inflation volume in a water bath at 37°C.

**If the Access Kit 03.804.612S is used, be aware that the initial length of each balloon is smaller than the distance between tip and corresponding groove of the plunger.

PREPARATION OF INFLATION SYSTEM

Instrument

03.804.413S Inflation System

The Inflation System has an angled manometer that shows the pressure in the balloon in pounds/inch² (psi) and atmospheres (atm). The volume scale on the fluid chamber measures milliliters (mL).

Prepare one inflation system per balloon.

Prepare contrast medium. Contrast can be used alone, or a mixture can be used with a ratio of contrast medium to saline of up to 1:2.

Fill the inflation system with the prepared liquid contrast medium.

Precaution: Check the patient for allergy to the contrast medium prior to surgery.

Follow the manufacturer's recommendations for contrast medium use in the vertebral body.

Submerge/connect the end of the flexible line to the contrast solution source (1). Slide the white wings on the sides of the inflation system forward while pulling back on the white handle to fill the chamber with fluid. Release the wings when the plunger bottoms out and the chamber is filled with fluid. With the handle pointing up, tap the unit to clear air out of the gauge portion of the inflation system (1, inset).

Hold the inflation system with the handle facing downward. With the white wings still in the released position, keep forward pressure on the handle and rotate it clockwise to expel all the air in the barrel (2). Continue turning the handle clockwise, until solution starts to emerge and the leading edge of the red mark on the plunger reaches the zero "0" mark (2, inset).

Tip: To make gross adjustments to the plunger, slide the white wings forward to unlock the plunger.

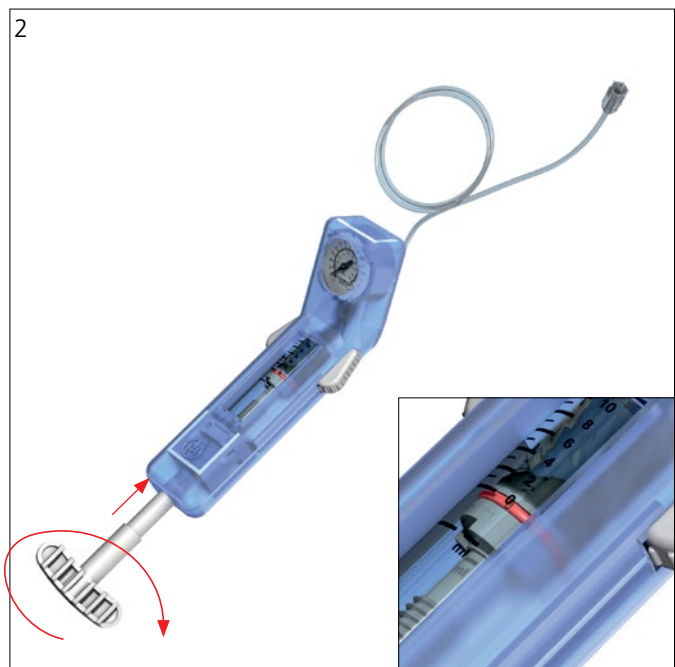
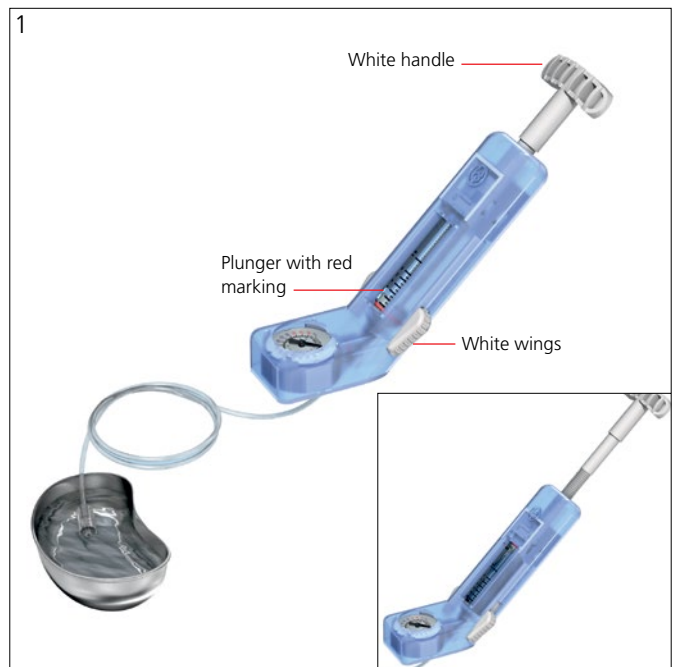

PREPARATION OF SYNFLATE VERTEBRAL BALLOON

Instruments

	SYNFLATE Balloons, sterile
03.804.700S	Small
03.804.701S	Medium
03.804.702S	Large

The SYNFLATE Vertebral Balloon Catheter uses a double lumen design. The inner lumen has a stiffening wire and the outer lumen delivers the inflation medium to the balloon. Both lumens are independent; it is the physician's choice to use the stiffening wire during inflation or not, but it must remain in position during insertion.

Remove the SYNFLATE Vertebral Balloon from the sterile packaging.

Note: The stiffening wire does not come fully attached. Make sure not to lose it while removing the catheter from the package. Thread it tightly to the inner lumen Luer for insertion, and then if desired, remove for balloon inflation.

The catheter is provided with the valve detached and separate in the package.

Thread the valve tightly to the side arm Luer (1).

Unscrew and remove the red cap (1).

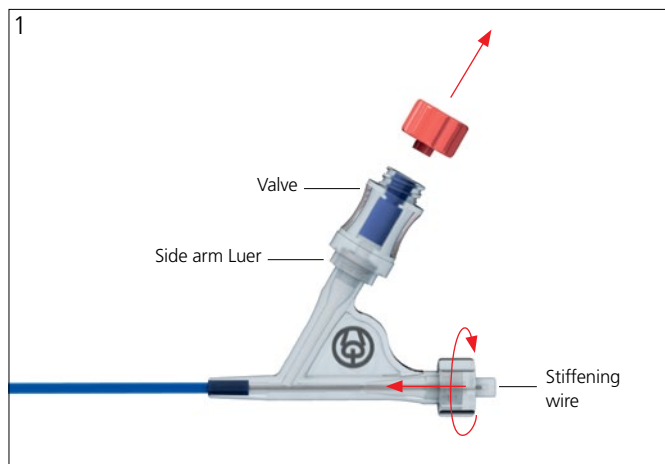

Create a vacuum

Connect the included locking syringe to the side Luer of the connector and draw a vacuum by pulling back the syringe plunger until it bottoms out (1). Make sure that the syringe is tightened well on the side Luer in order to maintain the vacuum.

The syringe plunger can be locked by rotating a quarter turn (2).

Remove the syringe while keeping the vacuum.

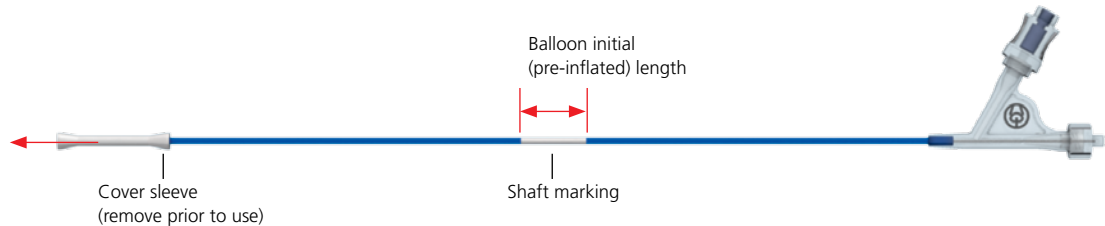
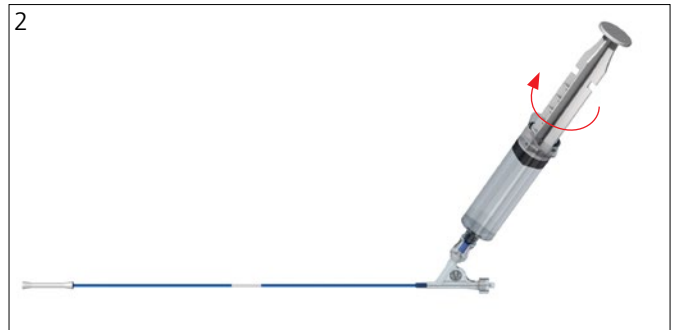
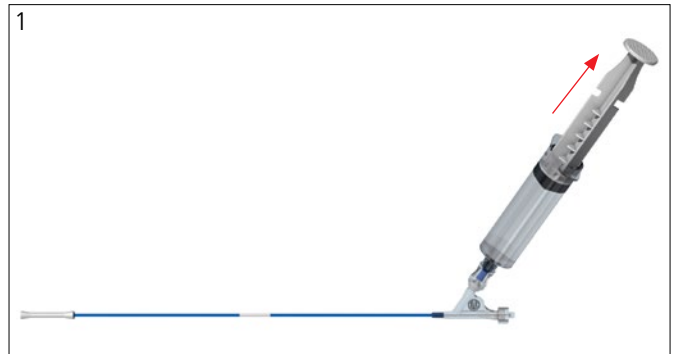

Remove cover sleeve

Remove the white cover sleeve from the balloon.

Note: Do not slide the cover sleeve towards the Luer lock, this may coat the catheter shaft with lubricant and make balloon insertion difficult.

Shaft marking

A white marking on the balloon catheter shaft indicates the initial (pre-inflated) length of the balloon. The marker can be used as a visual aid to identify when the balloon is completely outside of the working sleeve (3).

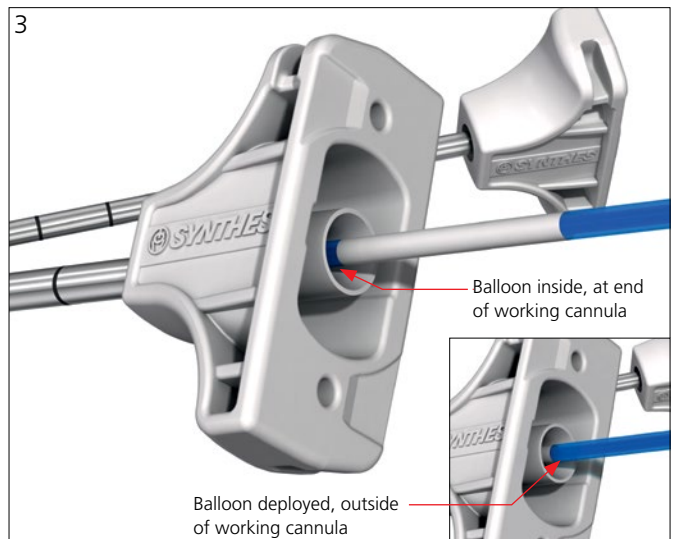

INFLATE THE SYNFLATE VERTEBRAL BALLOON

BALLOON INSERTION

- 1 Insert the balloon catheter under lateral radiographic control. The balloon is completely outside the working sleeve when white marking of the catheter shaft completely disappears into the working sleeve (1). Check the position under radiographic control and confirm the desired position under AP view.

Tip: Hold the balloon catheter firmly near the distal tip during insertion into the cannula.

Notes:

- If it is not possible to completely insert the balloon catheter so that the white marking of the catheter shaft disappears, it may be necessary to clear the path again using the plunger.
- For insertion, the catheter stiffening wire must be mounted to the catheter.
- Check the balloon position by identifying the markers of the balloon under fluoroscopy in AP and lateral view.
- If the balloon experiences high friction in the working sleeve, pull the balloon back and try advancing again.

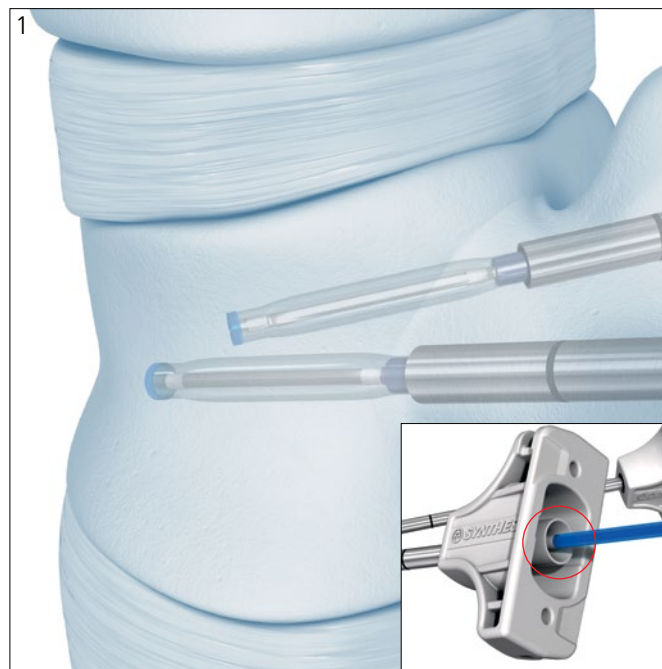

CONNECT THE INFLATION SYSTEM(S)

Connect the inflation system to the side port of the catheter (2).

Notes:

- The three-way stopcock supplied with the inflation system is not needed when using the SYNFLATE Vertebral Balloon.
- Do not connect the inflation system prior to catheter insertion; this may make the insertion difficult.
- Do not connect the inflation system to the Luer connection for the stiffening wire (back Luer).

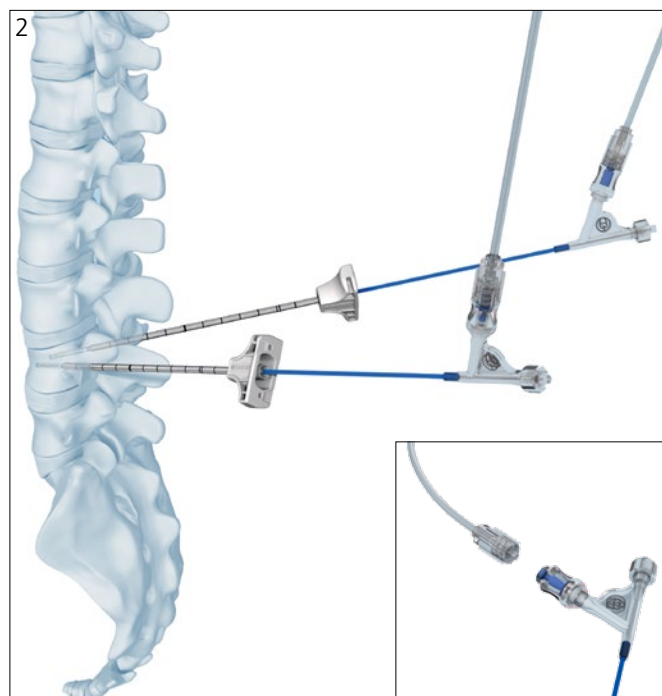

BALLOON INFLATION

① To inflate the balloon, slowly rotate the handle of the inflation system clockwise while monitoring the pressure and volume (1). Proceed with inflation slowly, stopping every few seconds to allow the bone to adjust to the pressure/volume changes.

② Use fluoroscopy to monitor balloon inflation.

Stop increasing inflation when any of the following happen.

- The desired clinical outcome is reached
- Balloon touches anterior wall of vertebral body
- The pressure reaches 30 atm (440 psi)
- The maximum volume is achieved
 - 4.0 mL for the small balloon
 - 5.0 mL for the medium balloon
 - 6.0 mL for the large balloon



Inflation Chart (maximum recommended)

	03.804.700S Small	03.804.701S Medium	03.804.702S Large
Maximum Inflation Volume	4.0 mL	5.0 mL	6.0 mL
Maximum Inflation Pressure	30 atm (440 psi)	30 atm (440 psi)	30 atm (440 psi)

Unconstrained Inflation Chart (unconstrained test condition)

	03.804.700S Small	03.804.701S Medium	03.804.702S Large
Inflation Volume	8.1 ± 0.6 mL	11.2 ± 0.7 mL	14.5 ± 1.2 mL
Inflation Pressure	8.1 ± 0.3 atm	7.2 ± 0.5 atm	6.4 ± 0.6 atm

Note: Expansion of balloons, pressure and volume on the inflation system must be monitored carefully. Image shown reflects one possible condition where maximum pressure was reached and the inflation should be stopped (1). All criteria for stopping inflation are listed previously.

Precautions:

- The balloons may leak or burst if they are filled beyond their maximum volume or pressure.
- The performance of the balloon catheter may be adversely affected if it comes into contact with bone splinters, bone cement, and/or surgical instruments.

For bilateral procedures, inflate each balloon alternately in increments.

Note: For bilateral procedures, it is important to ensure balloon inflation does not induce misalignment. As such, it may be necessary to inflate the balloons to different volumes to prevent or correct misalignment.

Note: Each balloon is for single use only and should not be reinserted or inflated after the initial use.

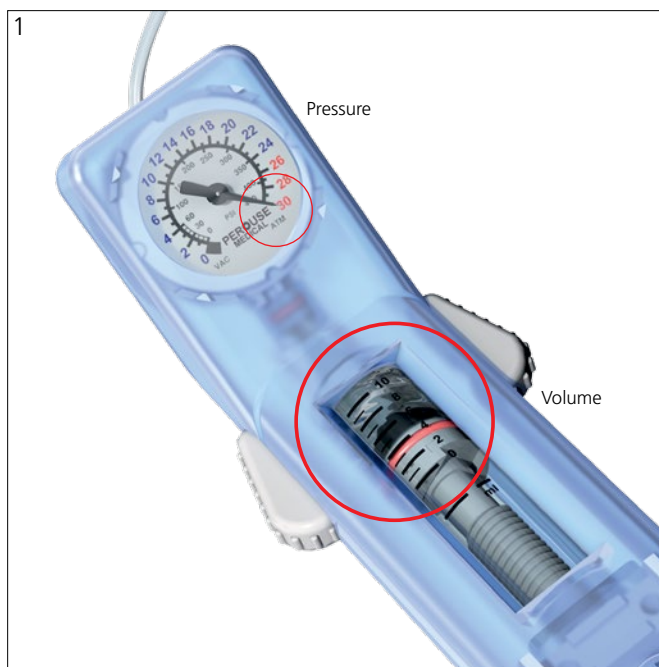

DEFLATE AND REMOVE

Gradually decrease the pressure by turning the handle of the inflation system counterclockwise, until the manometer indicates approximately 10 atm (150 psi) (1). Slide the wings forward while pulling the handle all the way back slowly. Wait a few seconds to fully collapse the balloon and draw a vacuum. Release the wings with the handle pulled all the way back, to seal the vacuum.

Hold the working sleeve(s) in place and pull firmly on the catheters to retrieve the balloons.

Note: Do not attempt to retrieve the balloon until the balloon is fully collapsed. One visual indication that the balloon is fully collapsed is when the contrast solution stops flowing back into the inflation system.

Note: If the balloon does not deflate, check the connections to the inflation system, draw a vacuum again, or assemble the vacuum syringe to draw a vacuum and collapse the balloon.

Important: The balloon material is not implant-grade material. If balloon rupture occurs, visually inspect the ruptured balloon to confirm no fragment is missing from it. If any portion of the balloon is missing, it must be retrieved from the patient using general surgical instruments and surgeon discretion.

Note: If it becomes difficult to remove the balloon catheter(s) through the working sleeve(s), twist the catheter counterclockwise while firmly pulling the catheter. If removal is still difficult, remove the balloon catheter(s) along with the working sleeve(s), then re-access the vertebral body using the working sleeve with the trocar assembly. Once re-access is complete, remove the trocar.

Precaution: Only reinsert the stiffening wire when the balloon is outside the patient.

For bilateral procedures, deflate and retrieve each balloon alternately in increments.

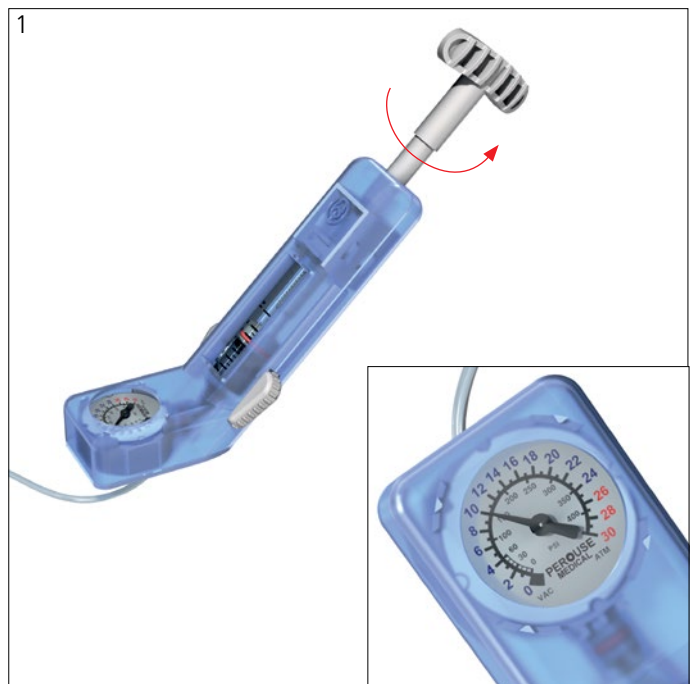

INJECT PMMA BONE CEMENT

Instrument options

03.804.517S	Access Kit, 10 Gauge, Diamond Tip/End Opening, Sterile
03.804.518S	Access Kit, 10 Gauge, Bevel Tip/End Opening, Sterile
03.804.519S	Access Kit, 10 Gauge, Diamond Tip/Side Opening, Sterile
03.804.520S	Access Kit, 10 Gauge, Bevel Tip/Side Opening, Sterile
03.804.612S	Access Kit

Follow the manufacturers' recommendations for PMMA use in the vertebral body.

Remove the injection needle assembled with the clip from package.

Move the clip to the starting marker position (1, 2). In this position, the distal tip of the injection needle will be in line with the distal end of the working sleeve upon insertion.

- Under fluoroscopy insert the injection needle with clip into the working sleeve and rotate the clip clockwise to lock it to the working sleeve (3).

Note: Do not use the biopsy kit for cement application.

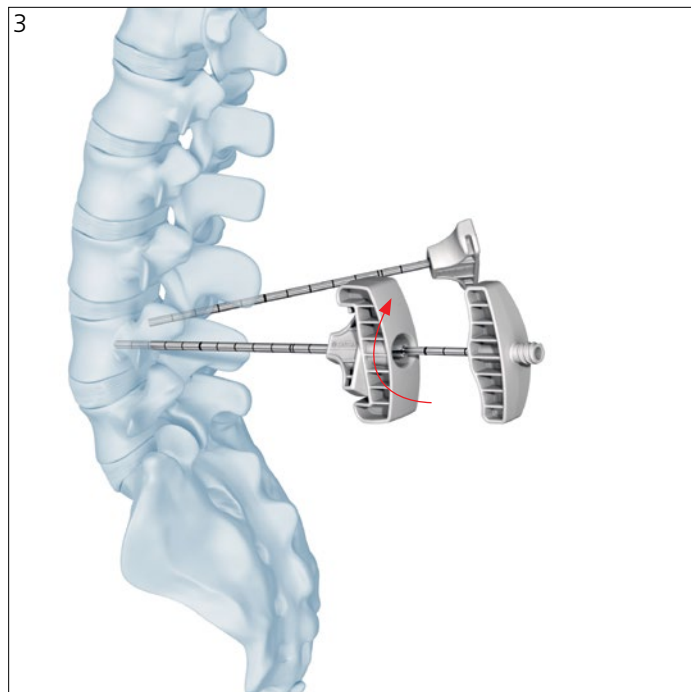
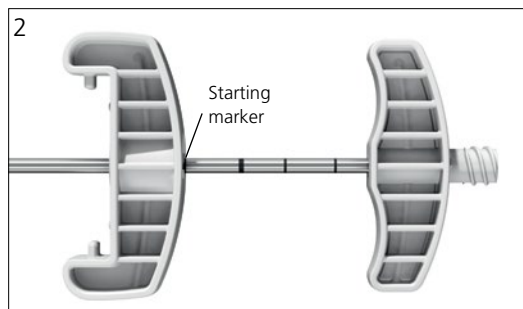
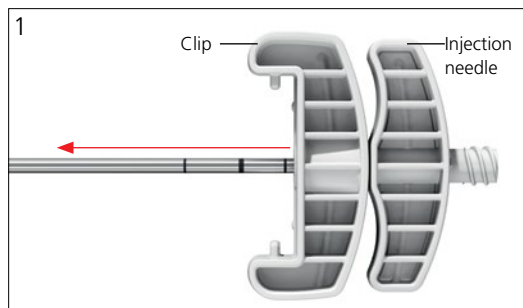

Connect a cement delivery system via the Luer lock (1).

For bilateral procedures, repeat on the contra-lateral side.

- Under lateral fluoroscopy, inject the PMMA cement (2). If using the side-opening needle, the direction of the cement flow can be changed by orienting the handle of the side-opening needle to correspond to the direction of the cement flow. The arrow on the handle of the side opening needle corresponds to the side of the opening. The cement should be contained within the vertebral body.

Notes:

When using an injection system, confirm that the system is compatible.

Hold the injection needle while disconnecting the syringe to prevent the injection needle from moving.

If using a bilateral approach, alternately fill both sides in increments. It is important to see the filling behavior of both needles. Once the filling of one side is accomplished, the lateral view of the opposite side is hidden by the cement, which makes monitoring the flow more difficult.

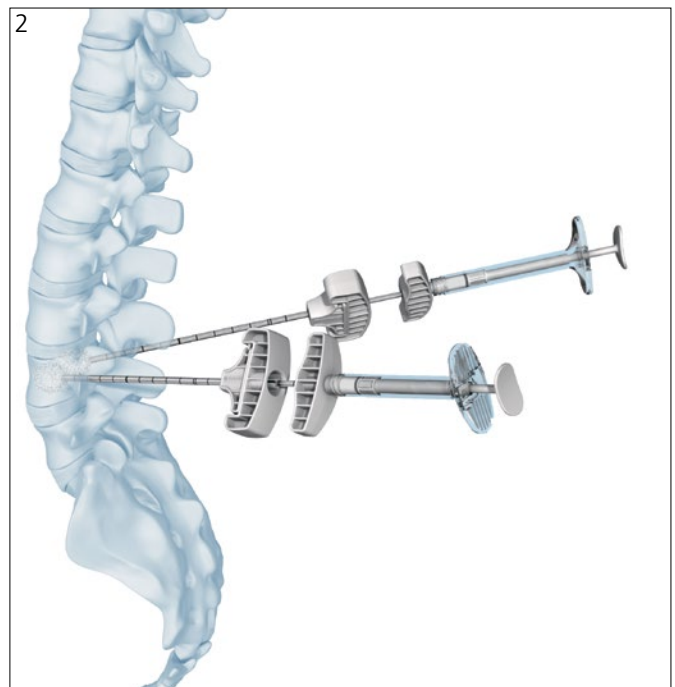
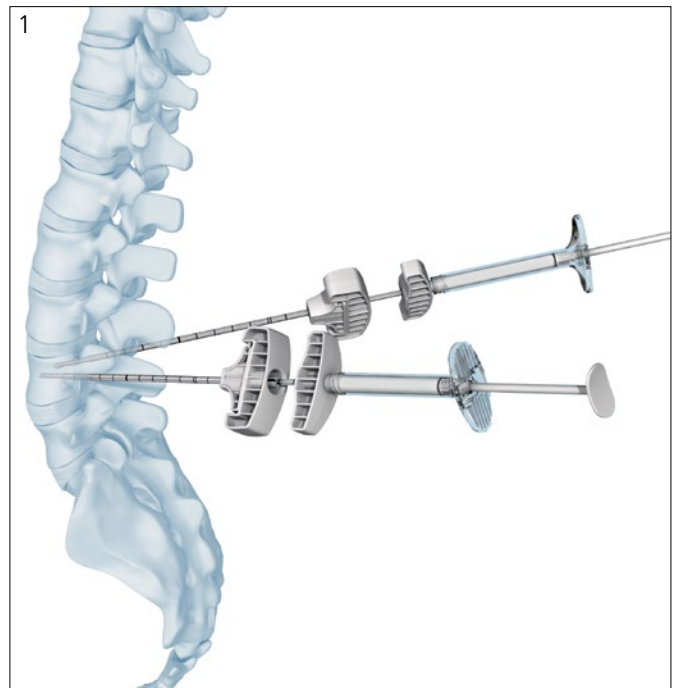

Warning: Closely monitor the PMMA cement injection under fluoroscopy to reduce the risk of cement leakage. Severe leakage can cause death or paralysis. If cement leakage is observed during the procedure, STOP injecting and consider: waiting for the injected cement to harden, repositioning the needle, adjusting the needle direction, or stopping the procedure. If desired, continue cement injection slowly, and carefully evaluate for further leakage. If further leakage is observed, cease bone filler injection.

Optional injection needle cleaning can be performed using the stylet contained in the single pack access kit*.

Refer to the manufacturer's instructions for proper waiting times required prior the removal of side-opening needle(s) and working sleeve(s) (1).



Warning: PMMA cement preparation, injection and setting times vary by product. Refer to manufacturer instructions prior to surgery and plan accordingly. If the injection needle with the working sleeve is removed too early, there may be a risk of pulling cement fibers into the muscle tissue. If this happens, cement residue should be removed from the soft tissues.

Close the wound.

Refer to IFU for side-opening needle for specific instructions for use, contraindications and warnings.

*Access Kit 03.804.6125 does not contain a stylet.

POSTOPERATIVE CARE

Place the patient in the supine position after surgery to compress the wound. Bruising may occur at the puncture sites. The patient may then be mobilized at the physician's discretion.

INSTRUMENTS

SYNFLATE Vertebral Balloons, Sterile

Product No.	Description	Volume	Initial length
03.804.700S	Small	4 mL	10 mm
03.804.701S	Medium	5 mL	15 mm
03.804.702S	Large	6 mL	20 mm



03.804.517S Access Kit, 10 Gauge, Diamond Tip/End Opening, Sterile

Contains:

- 1 Working sleeve
- 1 Trocar diamond tip
- 1 Plunger (not used with Cavity Creation Instrument)
- 1 Injection needle, End Opening with clip
- 1 Stylet

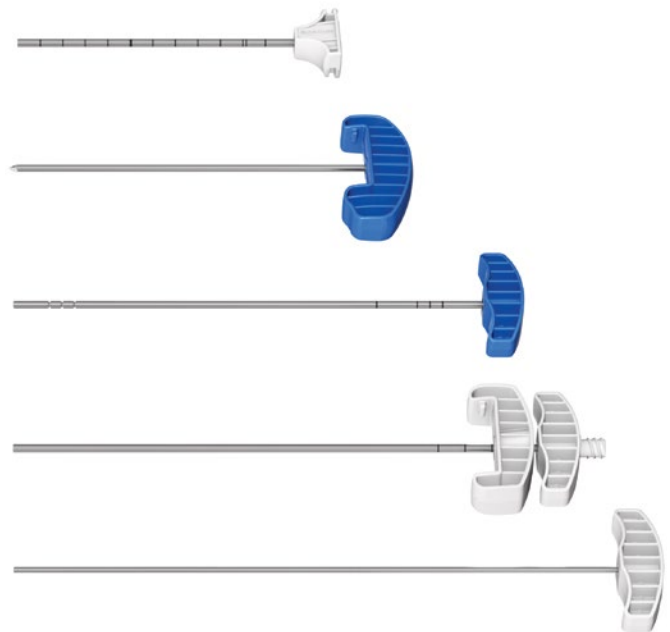

03.804.518S Access Kit, 10 Gauge, Bevel Tip/End Opening, Sterile

Contains:

- 1 Working sleeve
- 1 Trocar bevel tip
- 1 Plunger (not used with Cavity Creation Instrument)
- 1 Injection needle, End Opening with clip
- 1 Stylet

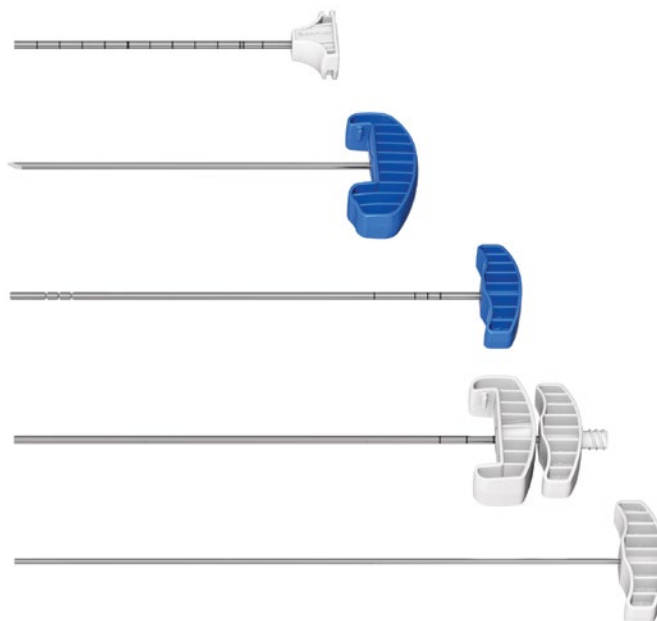

03.804.519S Access Kit, 10 Gauge, Diamond Tip/Side Opening, Sterile

Contains:

- 1 Working sleeve
- 1 Trocar diamond tip
- 1 Plunger (not used with Cavity Creation Instrument)
- 1 Injection needle, Side Opening with clip
- 1 Stylet

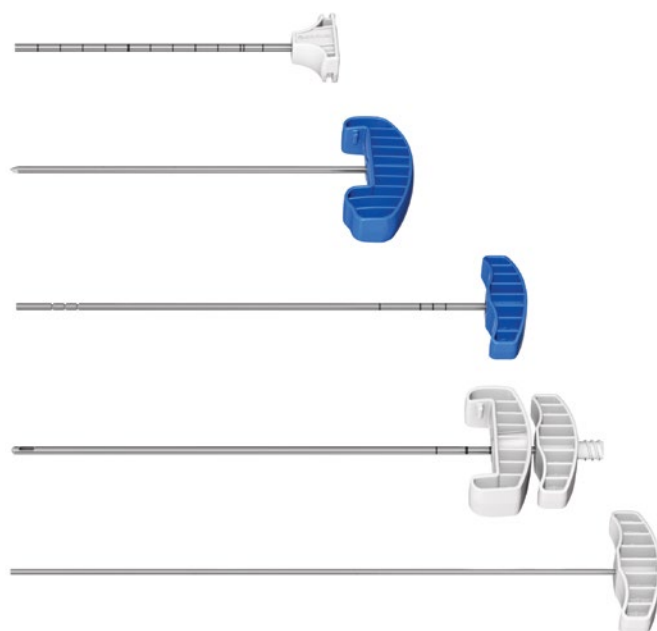

03.804.520S Access Kit, 10 Gauge, Bevel Tip/Side Opening, Sterile

- Contains:
 1 Working sleeve
 1 Trocar bevel tip
 1 Plunger (not used with Cavity Creation Instrument)
 1 Injection needle, Side Opening with clip
 1 Stylet

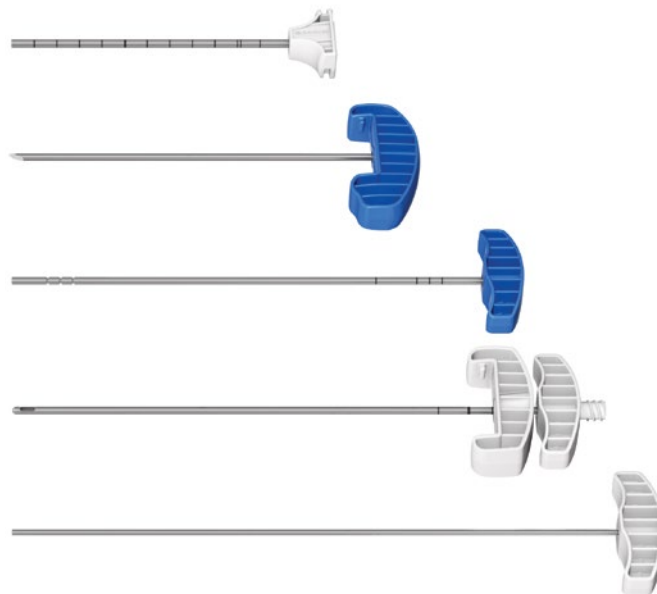

03.804.521S Access Drill, 10G, Sterile

- Contains:
 1 Drill



03.804.522S Biopsy Kit, 10G, Sterile

- Contains:
 1 Biopsy needle
 1 Stylet

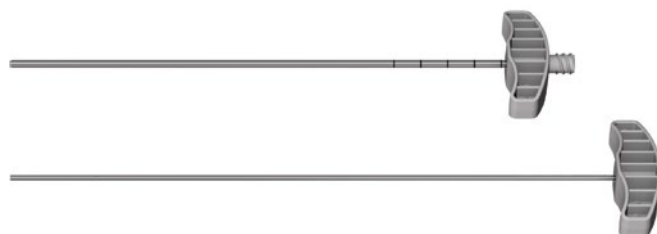

03.804.413S Inflation System, Sterile



Alternative Instrument

03.804.612S Access Kit, Sterile

Instruments for double access with trocar or guide wire.

Contains:

- 2 Guide wires
- 2 Working sleeves with cannulated trocar
- 2 Trocars (diamond)
- 1 Access drill
- 1 Plunger
- 2 Cement needles with clip

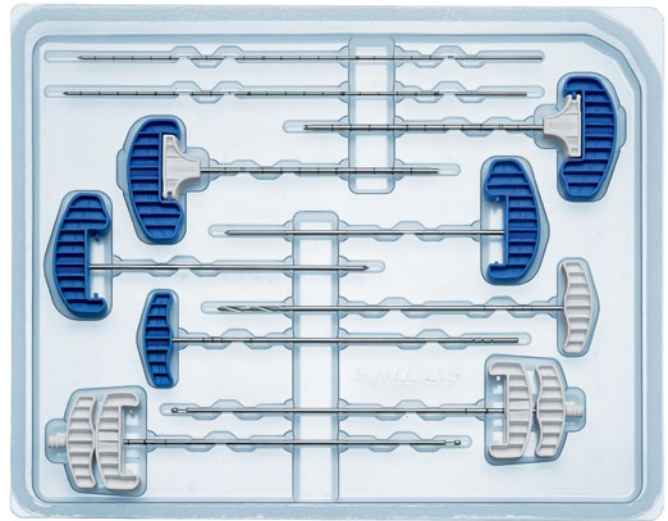

03.804.613S Biopsy Kit, Sterile

Contains:

- 1 Biopsy needle
- 1 Stylet



Limited Warranty and Disclaimer: DePuy Synthes Spine products are sold with a limited warranty to the original purchaser against defects in workmanship and materials. Any other express or implied warranties, including warranties of merchantability or fitness, are hereby disclaimed.

WARNING: In the USA, these products have labeling limitations. See package inserts for complete information.

CAUTION: USA Law restricts these devices to sale by or on the order of a physician.

To order in the U.S. call, Johnson & Johnson Health Care Systems Inc. Customer Support Services at 800-255-2500.

Not all products are currently available in all markets.

*Manufactured or distributed in
the United States by:*

Synthes USA, LLC
1101 Synthes Avenue
Monument, CO 80132
USA
Tel: +1 (800) 227-6633

www.depuysynthes.com