

EXPEDIUM VERSE[®] Spinal System



CONTENTS

1. PRODUCT OVERVIEW	1		
FEATURES AND BENEFITS	1		
IMPLANT DESIGN	5		
INSTRUMENT DESIGN AND SET CONFIGURATION	6		
SET CONTENTS	7		
2. SURGICAL TECHNIQUE	9		
SCREW BED PREPARATION	9		
• Cannulation	9		
• Tapping	10		
SCREW DELIVERY	11		
• Poly Driver Assembly	11		
• Loading the EXPEDIUM VERSE Screw	12		
• Delivering the EXPEDIUM VERSE Screw	12		
• Adjusting the Polyaxial Screw Head	12		
CEMENT DELIVERY (OPTIONAL)	13		
• Assembly of the Alignment Drive	13		
• Alignment of the Screw	13		
• Cement Preparation	14		
• Connection of Cannula to the Cement Reservoir	14		
• Attachment of Cement Cannula to Alignment Guide	14		
• Cement Delivery	15		
• Removal of Delivery Cannula	15		
• Subsequent Level Augmentation	16		
• Removal Of Alignment Devices	16		
• Residual Cement Removal	16		
ROD INSERTION	17		
• Rod Contouring	17		
• Rod Placement	18		
POLYAXIAL TO MONOAXIAL CONVERSION	19		
CORRECTION MANEUVERS	20		
• Segmental Translation	20		
– Set Screw Insertion and Rod Capture	21		
• Rod Rotation	23		
• Vertebral Body Derotation	24		
– Quick Stick Assembly and Attachment	25		
– En Bloc Vertebral Body Derotation with the EXPEDIUM VERSE System	26		
– Segmental Vertebral Body Derotation with the EXPEDIUM VERSE System	27		
• Compression and Distraction	30		
FINAL TIGHTENING	32		
TAB REMOVAL	34		
REDUCTION WITH FLEX CLIP REDUCER	35		
3. PRODUCT CATALOG	37		
TRAY CONTENTS	37		
INSTRUMENTS	42		
HANDLES & ADAPTORS	43		
SCREW INSTRUMENTS	44		
ROD REDUCTION AND DEROTATION	44		
ROD INSTRUMENTS	45		
TAB REMOVAL	46		
CEMENT DELIVERY INSTRUMENTS	46		
CASES AND TRAYS	47		
IMPLANTS	50		
4. APPENDIX	56		
5. USAGE	57		
6. POSTOPERATIVE MOBILIZATION	58		
7. CONTRAINDICATIONS	58		
8. REFERENCES	59		

1. PRODUCT OVERVIEW

The EXPEDIUM VERSE SPINAL SYSTEM has two configurations. The first configuration utilizes the classic solid shank, double lead threadform found on Expedium 5.5: in this document we will be referring to the classic solid screw version as the EXPEDIUM VERSE Polyaxial Screw. The second is a more advanced, feature rich configuration which adds a fully cannulated shank with fenestrations and the Cortical Fix threadform at the proximal end of the screw: this version is known as the EXPEDIUM VERSE Fenestrated Cortical Fix Polyaxial Screw.

FEATURES AND BENEFITS

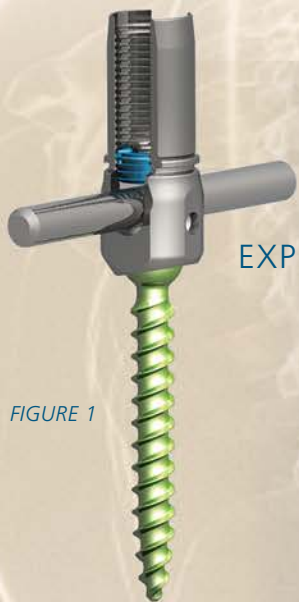
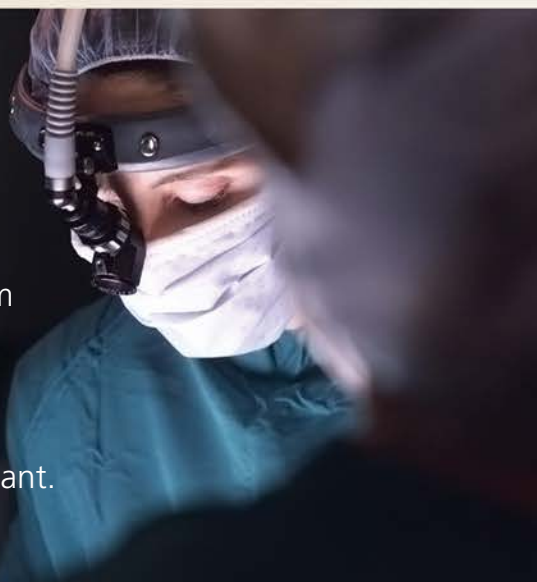

FIGURE 1

EXPEDIUM VERSE Spinal System

enables surgeons to perform
multiple correction maneuvers
with **one** versatile implant.



EXPEDIUM® Pedigree

The EXPEDIUM VERSE System builds upon the more than ten years of clinical experience with the comprehensive EXPEDIUM 5.5 System. Each implant component has been scrutinized and refined to deliver the features and performance needed to address complex spine pathologies.

Simplicity through Design

The EXPEDIUM VERSE Pedicle Screw serves as a powerful instrument to facilitate correction maneuvers. The result is a significant reduction in the number of instruments required for fusion procedures, potentially simplifying the back table and reducing the costs associated with reprocessing.

Speed and Versatility

The EXPEDIUM VERSE Pedicle Screw combines the attributes of multiple screw types, offering intraoperative flexibility by allowing the surgical staff to address unplanned circumstances with one versatile implant, ultimately delivering a more predictable intraoperative experience.

Easier Rod Capture with Powerful and Controlled Correction

The “hypermobility” or increased angulation of the polyaxial head in combination with the reduction tabs simplify rod capture while providing a powerful threaded reduction mechanism that accommodates controlled approximation of the spine to the rod.

EXPEDIUM VERSE Polyaxial Pedicle Screw

FIGURE 2

Extended Tabs with Loading Zone

Powerful integrated reduction with an alignment feature

TOP NOTCH® Feature

The Top Notch Feature helps various instruments easily connect to the implant and simplifies intraoperative maneuvers.

Head Drag

A drag mechanism enables the implant head to retain alignment, simplifying rod capture

Hypermobile Head with a Favored Angle

The favored angle provides up to 84° of angulation,* providing the benefits of a side loading implant with the ease of use of a top tightening system.

X25 Drive Feature

For the first time in an EXPEDIUM 5.5 Pedicle Screw, the EXPEDIUM VERSE System provides an X25 Drive Feature which allows for 43%** more torque to be delivered compared to the T20 Drive Feature provided in the EXPEDIUM 5.5 System.

Fully Threaded Dual-Lead Shank

The double-lead thread, self-tapping and self-centering shank is designed to provide faster screw insertion, enhanced bone purchase, and help ensure accurate placement within the pedicle.

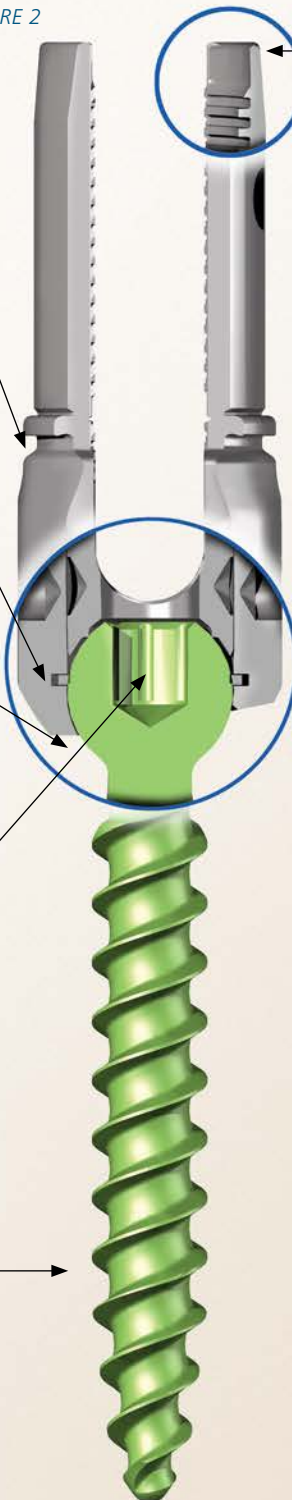
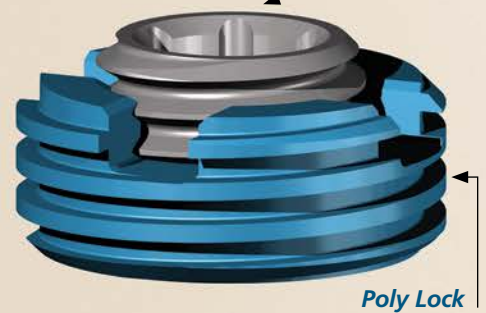

FIGURE 3

Rod Lock



VERSE Correction Key

The VERSE Correction Key delivers independent locking of the polyaxial head and rod, providing the benefit of a polyaxial screw with the correction control of a monoaxial screw.

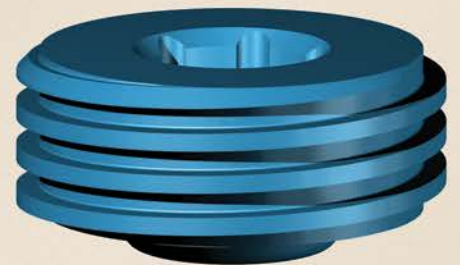

VERSE Unitized Set Screw

One-step locking of the polyaxial head and rod can be achieved with the VERSE Unitized Set screw when independent locking is not required.

* Data on file at DePuy Synthes Spine

** DVA-102149-TP Rev 4

EXPEDIUM VERSE Fenestrated Cortical Fix Polyaxial Pedicle Screw

The benefits of VERSE Polyaxial Screw plus...

FIGURE 4

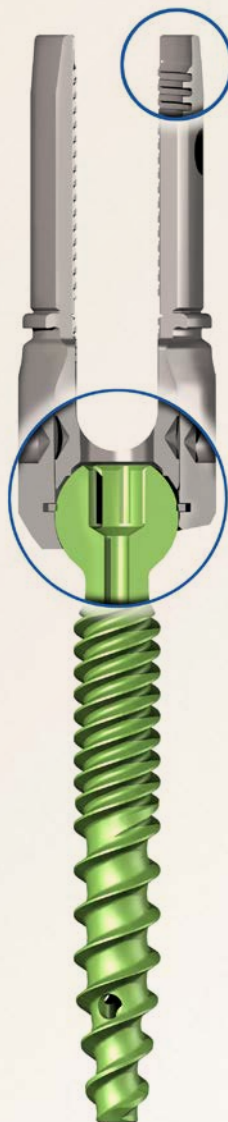

- The VERSE Fenestrated Cortical Fix Polyaxial Screw is a fully cannulated screw with fenestrations at the distal end.
- The cannulation and fenestrations allow for the injection of bone cement through the screw.

- Earlier thread start compared to standard EXPEDIUM, VIPER, and VERSE Screws
- Cortical Fix thread form is designed to engage the pedicle wall.
- Available in screw diameters: 4.35, 5, 6, 7, and 8mm
- Available in screw lengths: 30-80mm (in 5mm increments)
- 6 fenestrations for screws 45mm and longer
- 3 fenestrations for screws 40mm and shorter



Instruments for Cement Delivery

The EXPEDIUM VERSE cement delivery instruments consist of alignment devices and cement delivery cannulas which rigidly attach to the alignment devices. These instruments allow cement injection through the screw shank while staying clear of the fluoroscopy field.

FIGURE 5

Cannulation is 1.75mm in diameter

Cortical Fix Thread Form

Doubles the number of contact points within the cortical wall of the pedicle and increases the resistance to axial pull-out forces (compared to standard EXPEDIUM and VIPER screws).*

*Test data on file with DePuy Synthes Spine

Standard Double-Lead Thread

Integrates with the cancellous bone in the vertebral body.

Advances twice as far with each rotation (as compared to single lead screws).

Optimized Tip

Self-tapping and self-centering tip allows for insertion with or without tapping.

Fully cannulated design

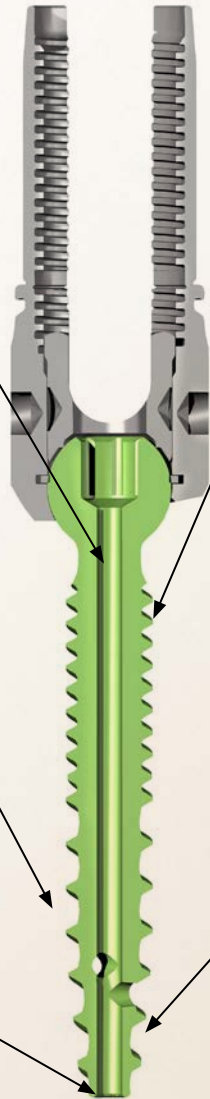

IMPLANT DESIGN

The EXPEDIUM VERSE System represents the next “verse” in posterior fixation. The EXPEDIUM VERSE Pedicle Screw combines three proven technologies into one versatile implant. Benefiting from the clinically proven design of the EXPEDIUM 5.5 and EXPEDIUM Favored Angle Screw Systems, each pedicle screw component and feature has been scrutinized and refined. The result is an implant which provides the features of polyaxial, monoaxial, and side loading screw technologies within a single screw type.

The “hypermobility” of the polyaxial head in combination with 17mm of reduction provides the surgeon with the tools necessary to capture the rod during complex spine deformity procedures while obviating the need for complex reduction instrumentation.

The VERSE pedicle screw is available in two versions. The VERSE Polyaxial Screw incorporates the EXPEDIUM double-lead, solid shank which has more than the years of clinical use globally. The VERSE Fenestrated Cortical Fix Polyaxial Screw is designed to meet the needs of challenging cases, building upon the feature set of the VERSE Polyaxial Screw and adding a fully cannulated Cortical Fix thread form with fenestrations. The Cortical Fix thread form doubles the number of contact points within the pedicle and increases the resistance to pull out*, ultimately

enhancing fixation within the pedicle. If more fixation is required, the fenestrated tip of the Fenestrated Cortical Fix Polyaxial Screw enables cement augmentation.

Using the EXPEDIUM VERSE System as a standalone system provides reduction capabilities at each operative level, accommodating techniques which promote the distribution of correction forces. The result is a reduction of stresses at the bone screw interface and a decrease in the potential for intraoperative screw migration.^{4,5,6}

The VERSE Correction Key adds independent polyaxial head and rod locking, providing intraoperative polyaxial to monoaxial screw conversion at any time during the procedure and at any location within the polyaxial head’s range of motion.⁷ With the EXPEDIUM VERSE Pedicle Screw, the implant is a polyaxial screw during rod capture when mobility is required and a monoaxial screw when correction forces need to be applied. The EXPEDIUM VERSE Unitized Set Screw provides one-step locking of the polyaxial head and rod should independent locking not be required.

The result is a versatile system which enables surgeons to leverage their technique when correcting spinal deformity with fewer implant types and instruments while delivering a more predictable intraoperative experience.



FIGURE 6

* Data on file at DePuy Synthes Spine

INSTRUMENT DESIGN AND SET CONFIGURATION

The EXPEDIUM VERSE Spine System has been developed in close collaboration with spine surgeons with an aim to improve operating room efficiency by leveraging the unique* combination of features of the EXPEDIUM VERSE Implant. The EXPEDIUM VERSE Instruments have been designed to enhance the capabilities of the implant while reducing the dependence on complex instrumentation. The “Implant Based Operating Room” reduces the set footprint and requires fewer instruments to treat complex spinal pathologies. As a result, the EXPEDIUM VERSE System reduces reprocessing and sterilization costs when compared to traditional instrument based

procedures. With fewer cases when compared to a traditional, instrument based system, the EXPEDIUM VERSE System reduces the costs associated with reprocessing and offers the potential to shorten the surgical staff’s learning curve without compromising the utility of the instrumentation.

Thoughtful instrument design allows surgeons to do more with less and the versatility of the system enables surgeons to apply many of the fundamental correction maneuvers, leveraging their correction technique while benefiting from a more optimized surgical flow and predictable intraoperative experience.

FIGURE 7

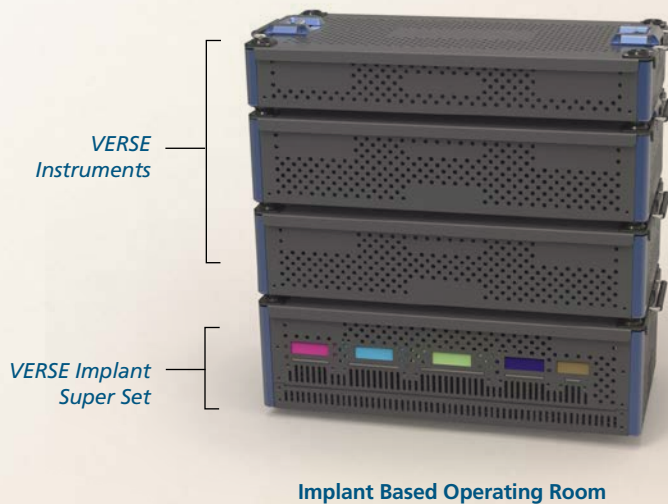

* U.S. Patent no. 6,736,820 - 7,785,354 - 8,409,260

SET CONTENTS

The EXPEDIUM VERSE Instruments build upon more than ten years clinical experience of EXPEDIUM 5.5 System. They improve upon the design of these established instruments while retaining the intuitive features which help surgeons to meet the challenge of complex pathologies.

EXPEDIUM VERSE Implants are available in an extensive range of sizes providing surgeons thoracolumbar and pelvic fixation options for adolescent and adult pathologies.

Available EXPEDIUM VERSE Screw Sizes

Diameter	Lengths
4.35mm	20-65mm
5mm	20-65mm
6mm	20-65mm
7mm	20-65mm
8mm	30-100mm



The EXPEDIUM VERSE SYSTEM is presented in four core cases.

When using VERSE Fenestrated Cortical Fix Polyaxial Screws, an additional half tray of instruments is required for cement delivery.

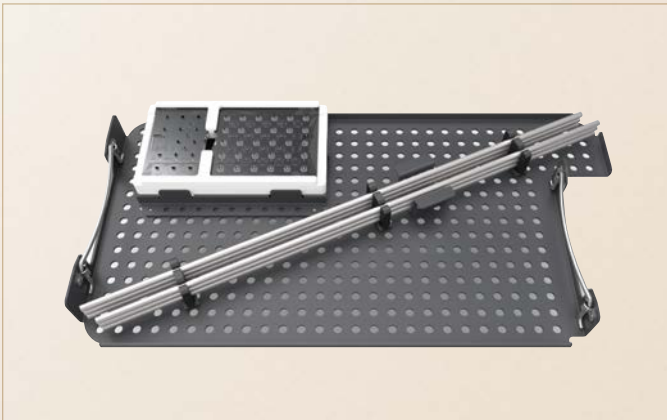
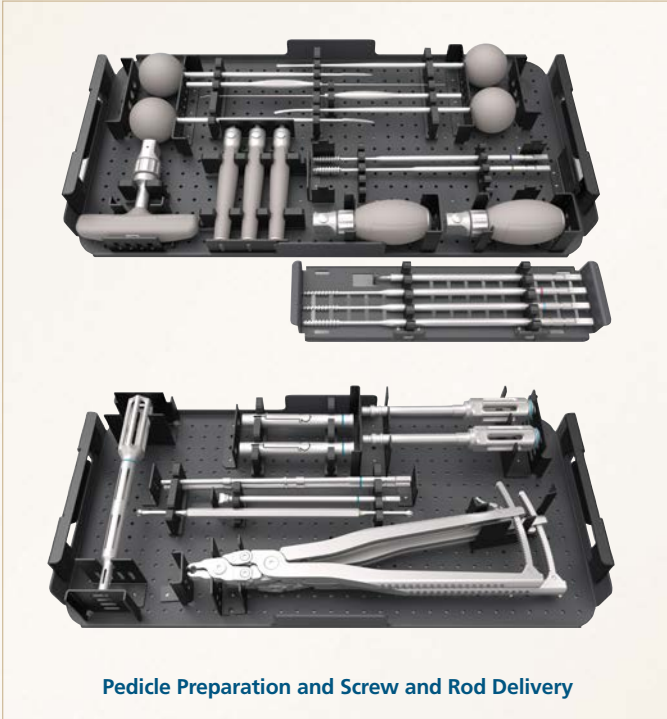

For set content details, please refer to the product catalogue at the end of this document.

2. SURGICAL TECHNIQUE

SCREW BED PREPARATION

CANNULATION

Equipment

2997-04-100	Pedicle Awl
2797-02-030	Straight Thoracic Pedicle Probe
2797-02-040	Curved Thoracic Pedicle Probe
2997-04-115	Straight Lumbar Pedicle Probe
2997-04-120	Curved Lumbar Pedicle Probe
2997-04-125/130	Ball Tip Feeler, Straight/Curved

Identify screw entry point and penetrate the cortex using a suitable instrument (awl, rongeur, high speed burr, probe, or equivalent).

Use the Ball Tip Feeler to verify pedicle cannulation and pedicle wall integrity.

FIGURE 8

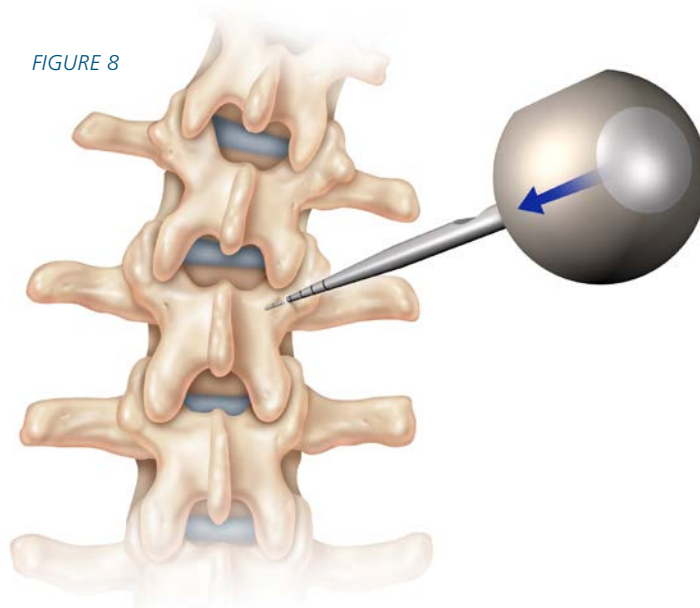

FIGURE 9



NOTE: Depth markings are provided in 10mm increments from 10mm through 60mm to provide depth of cannulation.

TAPPING

Equipment

2997-04-135	Ratcheting T-Handle
2997-04-140	Ratcheting Tear-Drop Handle
Double Lead Taps, Solid	
2997-04-040	4.35mm Double Lead Tap
2997-04-050	5mm Double Lead Tap
2997-04-060	6mm Double Lead Tap
2997-04-070	7mm Double Lead Tap
2997-04-080	8mm Double Lead Tap
2997-04-125/130	Ball Tip feeler, Straight/Curved
Double Lead Taps, Cannulated	
2997-04-940	4.35mm Double Lead Tap, Cannulated
2997-04-950	5mm Double Lead Tap, Cannulated
2997-04-960	6mm Double Lead Tap, Cannulated
2997-04-970	7mm Double Lead Tap, Cannulated
2997-04-980	8mm Double Lead Tap, Cannulated
2750-10-140/160	Ball Tip feeler, Straight/Curved

EXPEDIUM VERSE Screws have a fully threaded, tapered tip minimizing the need to tap. However, taps are provided for surgeon preference.

Clear surrounding soft tissue and bony anatomy to allow for full screw angulation.

Choose appropriate tap size per table.

Start with a smaller tap diameter and complete sequential tapping steps, increasing tap diameter until the desired diameter is reached. It is recommended to limit the change in hole diameter by one size and to tap to the full length of the screw intended to be placed.

FIGURE 10

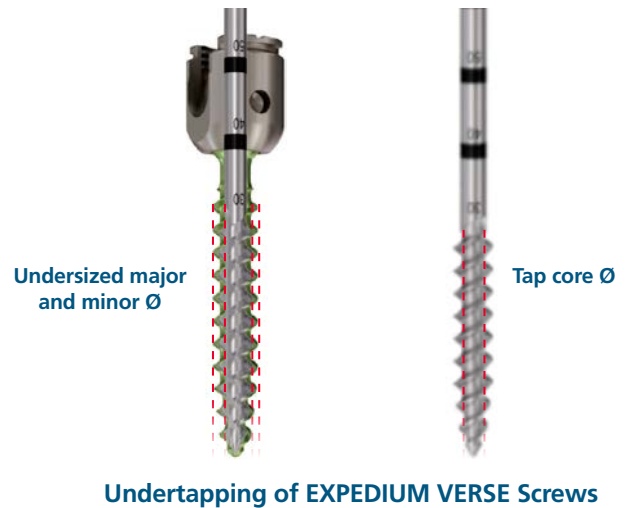

Undertapping of EXPEDIUM VERSE Screws

NOTE: In order to decrease the amount of torque required for large diameter screws, the degree of undertapping has been reduced for the 8mm tap. Reference the Tap Dimensions Table for values.

Tap Dimensions

Screw Size	Screw/Tap Undersizing		Tap Core Ø
	Major Ø	Minor Ø	
4.35mm	0.2mm	0.6mm	2.5mm
5mm	0.2mm	0.75mm	2.9mm
6mm	0.2mm	0.75mm	3.3mm
7mm	0.2mm	0.75mm	3.7mm
8mm	0.1mm	0.1mm	4.9mm

FIGURE 11



Two styles of ratcheting handles are provided within the set. The handles can be switched between Forward (F) – Locked (🔒) – Reverse (R) positions by rotating the collar of the handle.

To couple a tap to the handle, depress the button on the handle and insert the tap until the tap bottoms out. Release the button and verify that the tap is retained by gently pulling on it.

Place the ratchet in either Forward or Locked position. Apply the instrument to the entry point of the cannulation and tap to the desired depth.

For each tap, the thread length is 30mm. Additional markings are provided in 10mm increments to assess tapped depth.

Once the pedicle has been tapped to the desired depth, switch the ratchet to Reverse (R) or the locked position and turn the handle counter-clockwise to remove the tap.

Use a ball tip feeler to verify cannulation wall integrity and assess hole depth.

Remove the tap from the handle by depressing the button and then removing the tap.

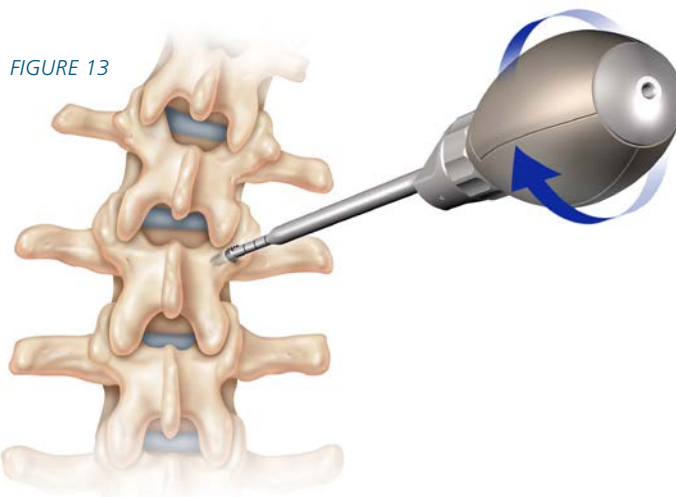

SCREW DELIVERY

Equipment

VERSE Polyaxial Driver Assembly - Comprised of:

2997-04-152	VERSE Poly Driver Handle
2997-04-155	VERSE Poly Driver Shaft
2997-04-160	VERSE Poly Driver Sleeve
2997-04-135	Ratcheting T-Handle
2997-04-140	Ratcheting Tear Drop Handle
2997-04-165	VERSE Head Adjuster

Choose desired screw length and diameter. To improve surgical flow and minimize non-operative time, two poly drivers have been included in the set to enable concurrent screw loading and screw placement.

POLY DRIVER ASSEMBLY

Insert the Poly Driver Shaft into the Poly Driver Handle and advance until the handle engages the Driver Shaft.

If desired, assemble the optional Poly Driver Sleeve to the Poly Driver Handle by depressing the release lever buttons and sliding the sleeve towards the handle. The sleeve allows the instrument to be held distally, improving stability. Additionally, the sleeve reduces the potential that soft tissue will become entangled around the driver during screw insertion.



LOADING THE EXPEDIUM VERSE SCREW

Attach the Poly Driver to a modular handle. Couple the driver to the screw by placing the X25 driver tip into the X25 feature of the EXPEDIUM VERSE Screw Shank.

Secure the implant by sliding the Poly Driver Handle toward the implant and rotating it clockwise.

NOTE: If it is desired to implant a EXPEDIUM VERSE Screw following removal of the extended tabs, the VERSE Poly Driver Shaft (removed from the VERSE Poly Driver Handle) or the VERSE X25 Inserter/Tightener can be used to implant the screw in the pedicle.

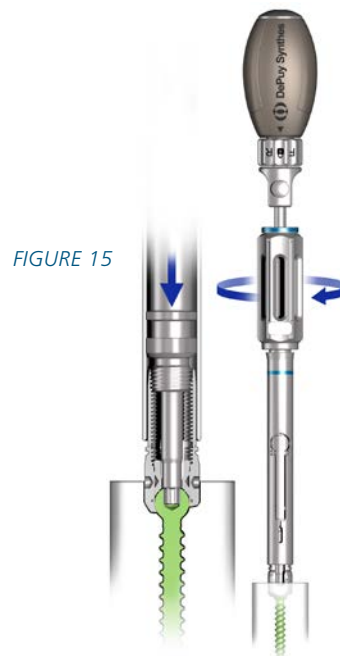

FIGURE 15

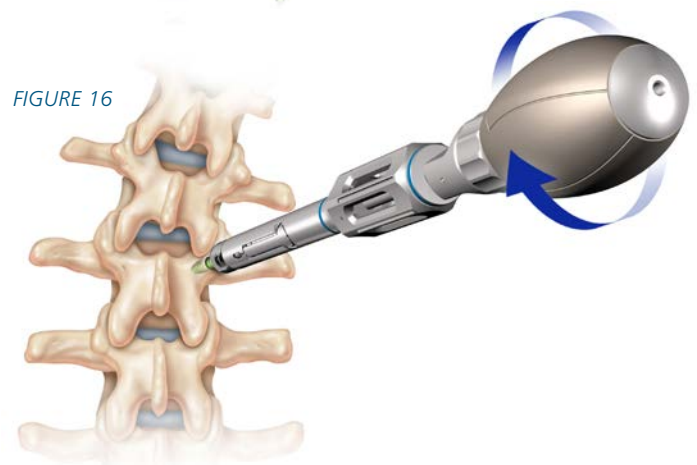

FIGURE 16

DELIVERING THE EXPEDIUM VERSE SCREW

Apply the instrument to the entry point of the pedicle and rotate modular handle clockwise until the implant is fully inserted. If additional torque is required, the Ratcheting T-Handle can be used. Once the pedicle screw is inserted, make sure the polyaxial head does not interfere with the bony anatomy so that the polyaxiality of the head is retained.

To adjust the screw head height, reverse the direction of the ratchet and rotate the handle counter-clockwise.

To release the implant turn the handle of the Poly Driver counterclockwise to disengage the driver from the screw head while holding the modular handle in a fixed position.

Confirm placement of screws and check screw length with fluoroscopy or plain X-rays prior to rod insertion.

FIGURE 17

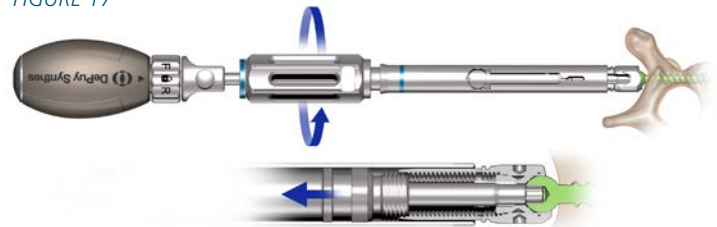

FIGURE 18

ADJUSTING THE POLYAXIAL SCREW HEAD

The EXPEDIUM VERSE Polyaxial Screw Head can be adjusted and positioned using the VERSE Head Adjuster. The drag feature of the implant will help to retain head position, facilitating rod capture.



CEMENT DELIVERY (OPTIONAL)

Required Equipment

2997-04-285	VERSE Alignment Device, Open
2997-04-295	VERSE Alignment Sleeve, Open
2797-26-500	Open Cannula (pre-packed sterile/single use)
2797-26-402	Plunger
2797-26-403	Alignment Device Cleaning Stylet
2797-26-511	Mini Cleaning Stylet

If enhanced fixation in the pedicle and the vertebral body is desired, the EXPEDIUM VERSE Fenestrated Polyaxial Screw provides a fenestrated screw shank will accommodated the delivery of cement.

Reference the prior surgical steps above for pedicle preparation and screw insertion.

ASSEMBLY OF THE ALIGNMENT GUIDE

Check that the alignment device and alignment sleeve are clear of any cement from prior use.

Insert the alignment device into the alignment sleeve and push the two pieces together until you hear a click.

ALIGNMENT OF THE SCREW

Align the tabs of the alignment sleeve with the rod slot in the screw head, ensuring that the soft tissue does not impinge on the connection of the alignment sleeve to the screw head.

Thread the assembled alignment guide into the screw head. This will align the screw shank to the screw head.

Confirm that the alignment device is fully seated by checking that the alignment guide and the alignment sleeve are fully seated (See detail).

Repeat this step for each screw intended for cement augmentation.

NOTE: The alignment device **MUST** be used for each screw intended for cement augmentation. Without the alignment device, there is a potential risk of cannula breakage. Use of the alignment device will prevent undue stress from being applied to the cannula.

NOTE: If a biopsy is completed prior to screw placement, care should be taken not to place the tip of the biopsy needle beyond the desired location of the screw tip in order to reduce the risk for cement leakage or extravasation.

NOTE: Fenestrated screws should **NOT** be placed bicortically. It is very important not to breach the pedicle wall or anterior cortex of the vertebral body to avoid cement extrusion into the retroperitoneal space. Use appropriate imaging techniques, such as fluoroscopy, to confirm screw placement.

FIGURE 19

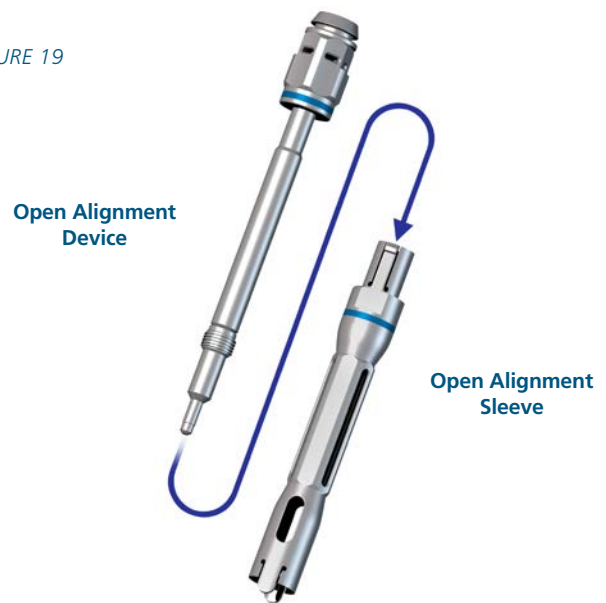
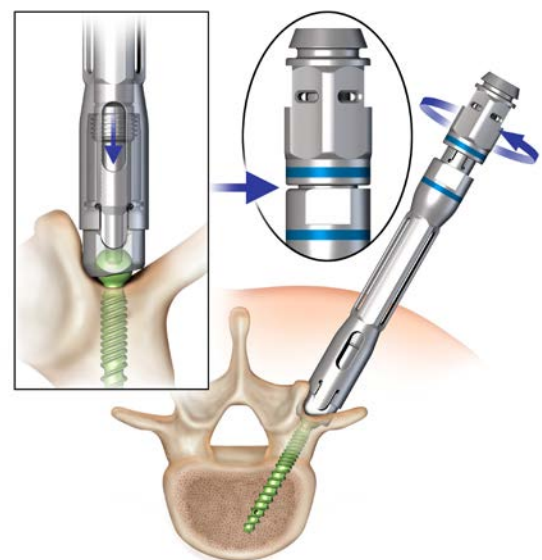

FIGURE 20



CEMENT PREPARATION

Once the VERSE Fenestrated Cortical Fix Polyaxial Screws are in place and the alignment devices are attached to those levels selected to be augmented, prepare the cement according to the manufacturer's published instructions.

NOTE: Bone cement should be prepared as per the cement package insert or surgical technique manual. Time/Temperature Graph provided in the package insert or surgical technique manual should be followed carefully.

CONNECTION OF CANNULA TO THE CEMENT RESERVOIR

Thread the CONFIDENCE SPINAL CEMENT reservoir onto the cannula.

NOTE: If using the V-Max Mixing and Delivery System and the Vertebroplastic Radiopaque Resinous Material, the CONFIDENCE System Luer Adapter (2839-99-001) is screwed onto the cannula before attaching those systems onto the cannula.

ATTACHMENT OF CEMENT CANNULA TO ALIGNMENT GUIDE

Place the cannula with cement reservoir through the alignment guide and into the screw shank. The cannula will click onto the alignment guide.

NOTE: To ensure that the cannula is correctly positioned to deliver cement, the cannula **MUST** click into place before proceeding to the next step.

When the cannula is properly positioned in the screw shank, the tip will be just above the first fenestration.

NOTE: If there is any trouble inserting the cannula into the screw shank, ensure that the alignment device is properly threaded into the screw head.

When augmenting multiple screws/levels with cement, attention must be paid not to exceed the working time of the cement prior to the completion of cement delivery through the screw. When the cement working time is close to completion, a new cement, cement delivery system package, and cannula should be used for any remaining levels/screws.

FIGURE 21



FIGURE 22

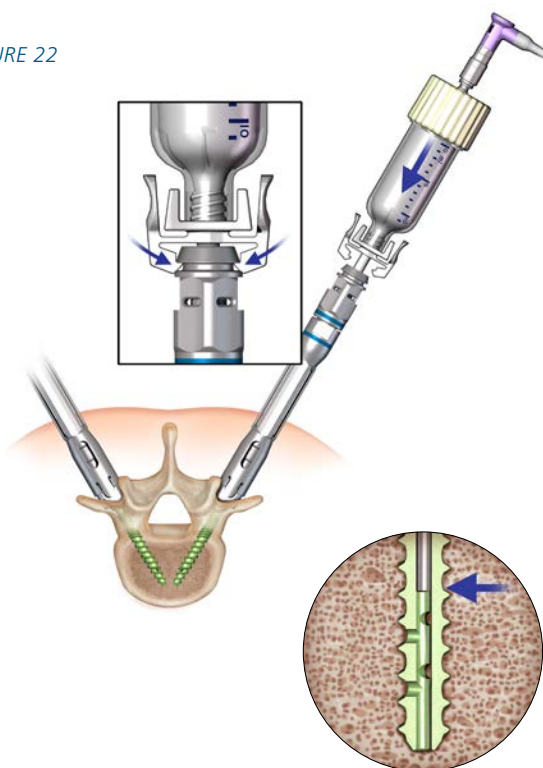

CEMENT DELIVERY

Follow the instructions from the respective bone cement and delivery system package inserts to introduce the cement through the delivery cannula.

Use fluoroscopy throughout the procedure to verify and monitor cement flow as appropriate.

NOTE: Controlled delivery is essential to proper screw augmentation. Overly aggressive cement injection may result in cement leakage and unsatisfactory results. Immediately stop cement injection if extravasation is detected.

FIGURE 23

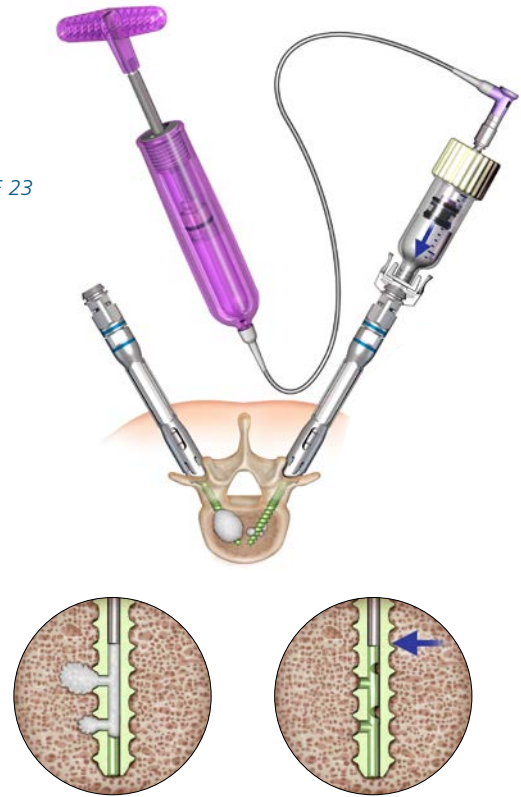

REMOVAL OF DELIVERY CANNULA

When the appropriate amount of cement has been introduced, stop cement introduction as indicated per the respective bone cement technique.

Disengage the cannula from the alignment guide by depressing the tabs on each side of the cannula and remove it from the screw as soon as cement injection is completed and flow has stopped through the cannula.

NOTE: It is essential to confirm that cement flow has stopped before disengaging the cement delivery system from the screw head.

FIGURE 24

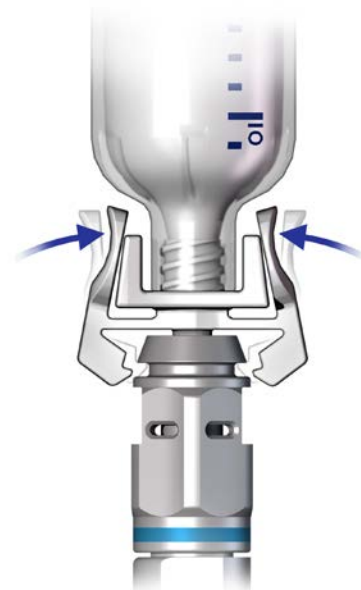

SUBSEQUENT LEVEL AUGMENTATION

Place the existing cannula and cement reservoir into the next alignment guide and repeat the procedure described above.

Repeat for each desired vertebral level, ensuring that cement flow has stopped between each level.

If an additional cement package is needed, remove the existing cannula and attach a new cannula.

If additional cement is needed beyond its working time, dispose of the cement and cannula. Use a new cannula and mix a new dose of cement for the remaining screws.

Optional Step: The plunger can be used to pass the cement remaining in the cannula into the screw after the cement reservoir has been emptied. Detach the reservoir from the cannula and proceed with plunger insertion.

FIGURE 25

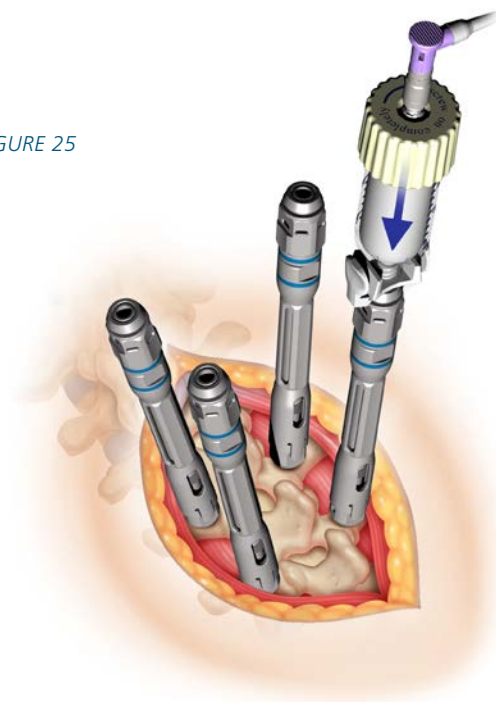

REMOVAL OF ALIGNMENT DEVICES

After the cement introduction, the alignment devices can be unthreaded from the screw head.

NOTE: After cement injection, no torsional movement should be applied to the screw throughout the cement setting time outlined in the respective package insert. At the end of the case, any opened cannulas must be discarded.

RESIDUAL CEMENT REMOVAL

After use, the Alignment Devices should be visually inspected for any cement.

If cement remains in the Alignment Device, insert the Stylet through the Alignment Device and rotate to ensure any cement is removed.

Insert the Mini-Stylet into the threaded tip of the Alignment Device.

If cement remains in the device, repeat cleaning steps above or return it to DePuy Synthes Spine.

ROD INSERTION

Equipment

2997-04-170	French Rod Bender
2997-04-175	Rod Clamp
2997-04-180	Double End 5.5 Rod Hex Wrench
2797-29-930	Table Top Rod Cutter

Alternative Equipment

2997-04-185/190	Coronal In-Situ Bender, Left/Right
2997-04-195/200	Sagittal In-Situ Bender, Left/Right

ROD CONTOURING

The EXPEDIUM VERSE Spinal System is a 5.5mm diameter rod system. Titanium alloy (Ti) and Cobalt-Chromium alloy (CoCr) rods have been included in the set. Select the rod material of choice, cut, and contour the rod. A French Rod Bender and in-situ sagittal and coronal benders are available in the set for rod contouring.

NOTE: The rod's mechanical properties will be an important factor in kyphosis restoration and derotation. A stiffer material such as CoCr will be more effective than the Ti rods in axial derotation and sagittal plane restoration, since less flattening of the rod can be expected.³ The rod strength, however, should be matched to the patient's bone density.

Caution: Do not reverse bend rods. Reverse bending may produce internal stresses which may become the focal point for eventual breakage of the implant.

FIGURE 26



Differential rod contouring can be used to achieve derotation of vertebral segments. Contour the concave rod with extra kyphosis which can apply derotational moments in the axial plane and also pull the apical vertebrae dorsally.

Contour the convex rod with less thoracic kyphosis to push down on the convex side of the vertebral bodies, thus displacing them anteriorly and decreasing the rib prominence.^{3,8,12}

FIGURE 27



ROD PLACEMENT

The EXPEDIUM VERSE Implant has a polyaxial head drag feature which allows for alignment of the screw head positioning, facilitating rod insertion.

Use the Rod Clamp to insert the rod into the openings of the EXPEDIUM VERSE Implants.

Place the rod into the openings of the EXPEDIUM VERSE Implants using the sagittal profile of the rod to closely approximate the position of the polyaxial screw and begin sequential rod capture. Start by loosely capturing the rod distally and proximally while working towards the apex. (FIGURE 29) An attempt should be made to capture the rod in all EXPEDIUM VERSE Screw tabs prior applying any correction forces. (FIGURE 33)

FIGURE 28

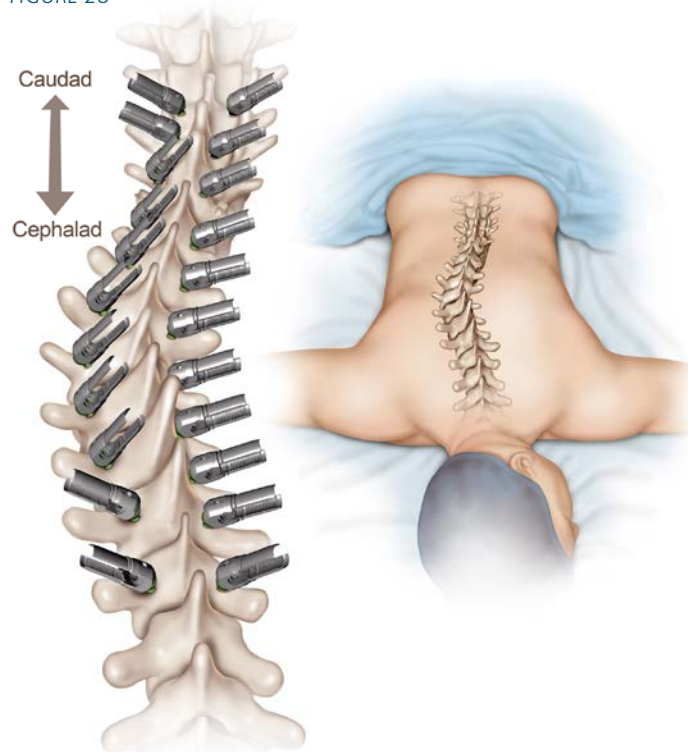
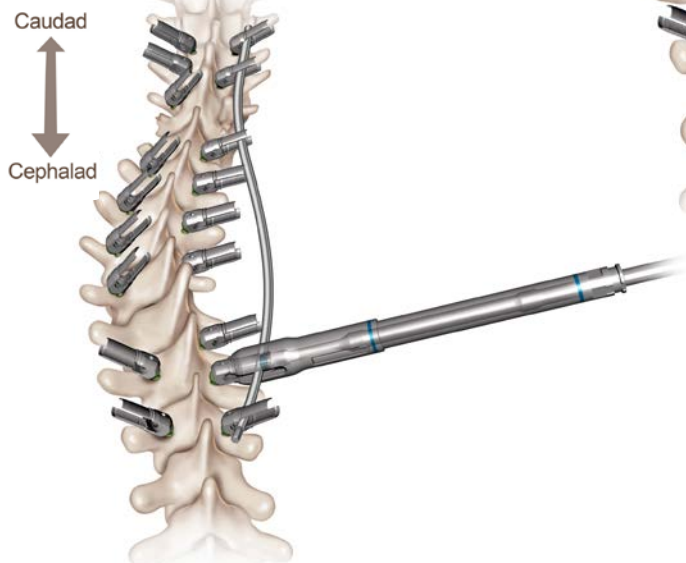

FIGURE 29



POLYAXIAL TO MONOAXIAL CONVERSION

Equipment

2997-04-220	VERSE Key Inserter/Tightener
2997-04-320	Torque Limiting Handle 80in-lb (9Nm)
2997-04-205	VERSE Facilitator
2997-04-355	VERSE Tab Ring
VERSE Quick Stick Assembly – Comprised of:	
2997-04-215	VERSE Quick Stick Sleeve
2997-04-217	VERSE Quick Stick Tube
2997-04-255	VERSE Counter Torque Handle

The VERSE Correction Key was designed with the intent to convert the EXPEDIUM VERSE Pedicle Screw into a monoaxial implant while allowing the screw to articulate about the rod. Tighten the Poly Lock of the VERSE Correction Key with the Torque Limiting Handle while applying counter torque to lock the polyaxial head.

Caution: A counter torque instrument must be applied when engaging the Poly Lock as well as during final tightening.

Proper counter torque can be applied by several means. The VERSE Counter Torque Handle can be used with either the VERSE Facilitator or the VERSE Quick Stick. (FIGURE 31)

There are two ways to engage the Facilitator or Quick Stick instruments. First, the open end of the Counter Torque Handle can be used to engage the flats on the proximal end of the tubular instruments. Second, depressing the button on the closed end of the Counter Torque Handle and sliding it over the proximal end of a Facilitator/Quick Stick will engage and retain the instrument, providing a counter torque assembly. (FIGURE 32)

For instructions on Quick Stick assembly and attachment to an implant, see the derotation section which follows.

Place the counter torque assembly over the head of the screw. With the VERSE Key Inserter/Tightener attached to the Torque Limiting Handle, insert the shaft through the counter torque assembly into the castle drive feature of the VERSE Correction Key Poly Lock. Tighten until there is a tactile release which indicates that the required 80in-lb (9Nm) of torque has been applied.

Relocate the counter torque assembly to additional screws where polyaxial to monoaxial conversion is desired and repeat the steps described above.

FIGURE 30

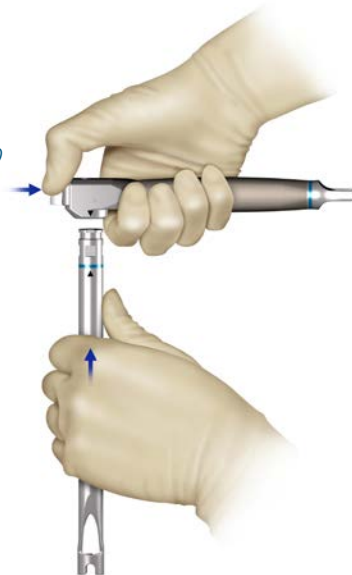

FIGURE 31



FIGURE 32



CORRECTION MANEUVERS

SEGMENTAL TRANSLATION

Equipment

2997-04-175	Rod Clamp
2997-04-180	Double End 5.5 Rod Hex Wrench
2997-04-170	French Rod Bender
2997-04-220	VERSE Key Inserter/Tightener
2997-04-230	VERSE X25 Inserter/Tightener
2997-04-145	Pencil Handle
2997-04-205	VERSE Facilitator

Alternative Equipment

2997-04-185/190	Coronal In-Situ Bender, Left/Right
2997-04-195/200	Sagittal In-Situ Bender, Left/Right
2997-04-355	VERSE Tab Ring

Segmental Translation is a widely used maneuver for the correction of coronal deformity. The main goal of this technique is to segmentally bring the spine to the contoured rod, allowing for coronal correction to occur.^{1,2,11}

The EXPEDIUM VERSE Spinal System provides extended tabs with 17mm of reduction. The combination of the reduction tabs and the hypermobility or extended range of polyaxial motion simplify rod capture. Consequently, the use of the EXPEDIUM VERSE Screw at each level permits a more uniform distribution of the forces required for correction, reducing the magnitude of stresses at the bone-screw interface and the potential of screw migration.¹ This maneuver can be performed in conjunction with other techniques to allow for sagittal, coronal, and axial correction. (FIGURE 33-35, 37-39)

FIGURE 33

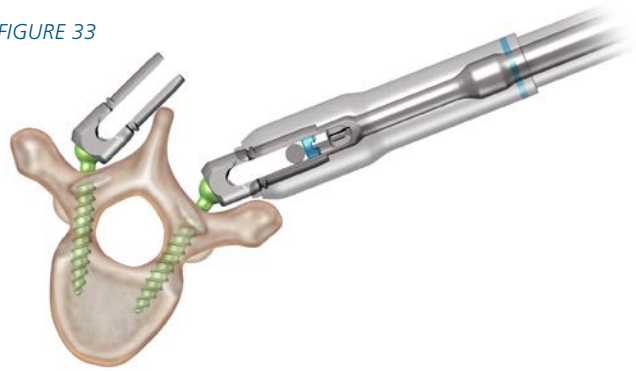

FIGURE 34

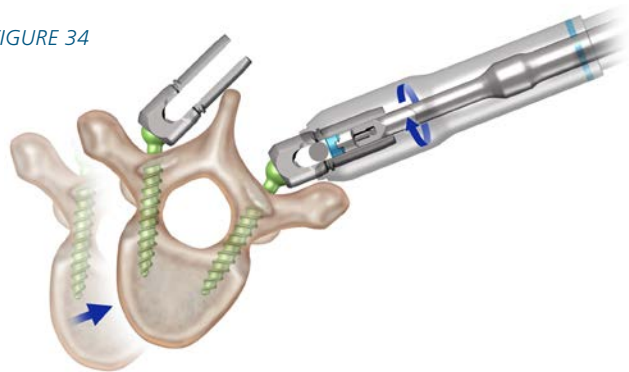
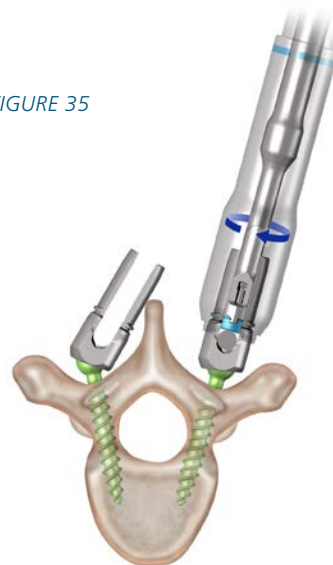

FIGURE 35



Set Screw Insertion and Rod Capture

The VERSE Correction Key and VERSE Unitized Set Screw are available in the EXPEDIUM VERSE System. The VERSE Correction Key (1997-21-000) allows for the independent locking of the polyaxial head and the rod. Consequently, the implant can be converted from a polyaxial screw to a monoaxial screw anywhere within the implant's range of motion while still allowing the rod to move below the VERSE Correction Key. This affords the surgeon the ease of rod capture without compromising control over the vertebral body.

Converting the implant to a monoaxial screw facilitates parallel compression and distraction and derotation maneuvers. If dual stage locking is not required, the VERSE Unitized Set Screw (1997-21-001) is also provided for one-step locking of the screw head and rod. For insertion of the VERSE Correction Key, the VERSE Key Inserter/Tightener should be assembled to the Pencil Handle. For insertion of the VERSE Unitized Set Screw, the VERSE X25 Inserter/Tightener should be assembled to the Pencil Handle.

NOTE: The diameter of the Pencil Handle has been designed with the intent to enhance tactile feedback during VERSE Correction Key or VERSE Unitized Set Screw engagement and during reduction while inducing a technique which utilizes staged reduction across multiple operative levels.

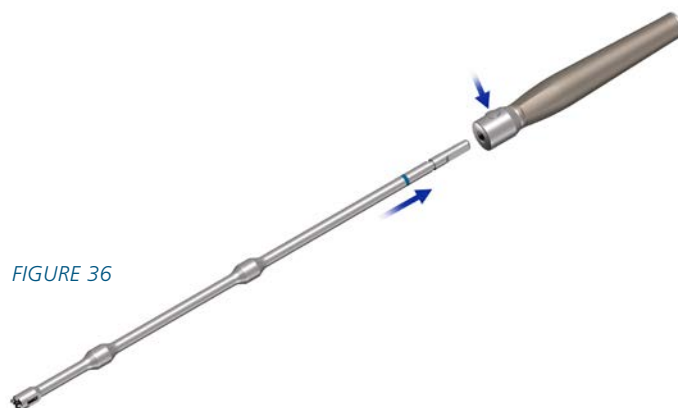

FIGURE 36

FIGURE 37

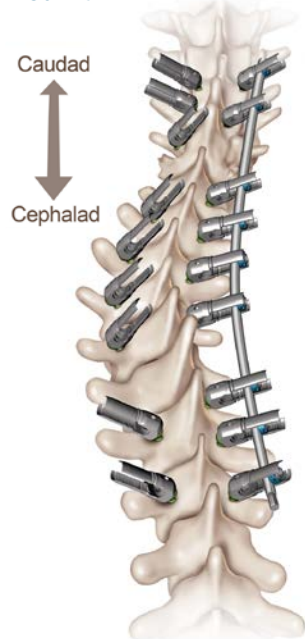

FIGURE 38

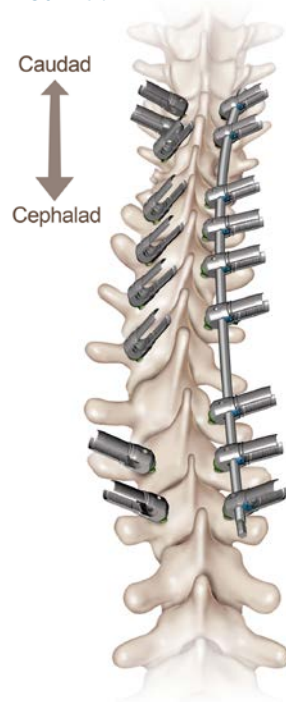
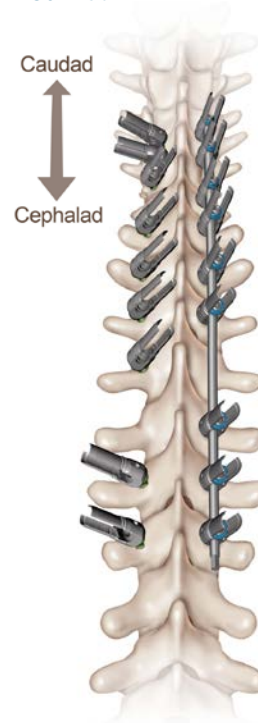

FIGURE 39



The EXPEDIUM VERSE Pedicle Screw incorporates an alignment zone within the extended tab. This assists in aligning the threads of the VERSE Correction Key or Unitized Set Screw with the pedicle screw.

It is recommended that a VERSE Facilitator be used while inserting a VERSE Correction Key or VERSE Unitized Set Screw and during rod reduction. The facilitator will provide additional alignment, further reducing the potential of cross-threading, and will also protect against premature breakage of the tabs during reduction and application of corrective forces. A VERSE Tab Ring can also be placed on the tabs prior to introduction of the VERSE Correction Key or VERSE Unitized Set Screw to provide similar benefit and protection of the tabs.

Caution: During segmental translation with the VERSE Correction Key, the Rod Lock should not advance beyond the underside of the Poly Lock. If the Rod Lock advances beyond the Poly Lock prior to final tightening:

- Independent poly and rod locking is not achievable
- The VERSE Key Inserter/Tightener may not properly engage the implant.

FIGURE 40



FIGURE 41



FIGURE 42

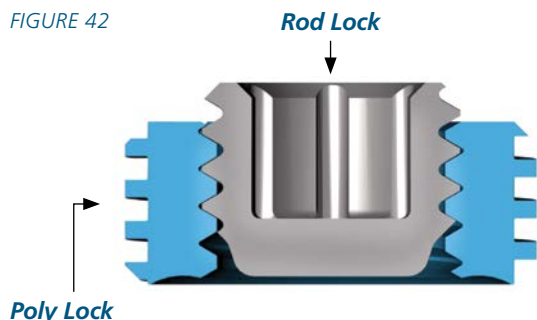

Insert the concave rod into the proximal and distal anchors. If the rod has both kyphosis and lordosis, it may be possible to only insert into the distal anchor to begin.

After proximal and/or distal foundations are secured, the spine is translated to the rod segmentally by reducing the rod into the reduction tabs using either the VERSE Correction Key or Unitized Set Screw implants. The benefits of force distribution are realized when all levels are recruited in a staged reduction process.^{4,6}

During rod reduction, once the VERSE Correction Key or Unitized Set Screw contacts the rod and resistance increases, it is recommended to move to another level to continue reduction. Repeat this process until the rod has been captured at all levels.

FIGURE 43

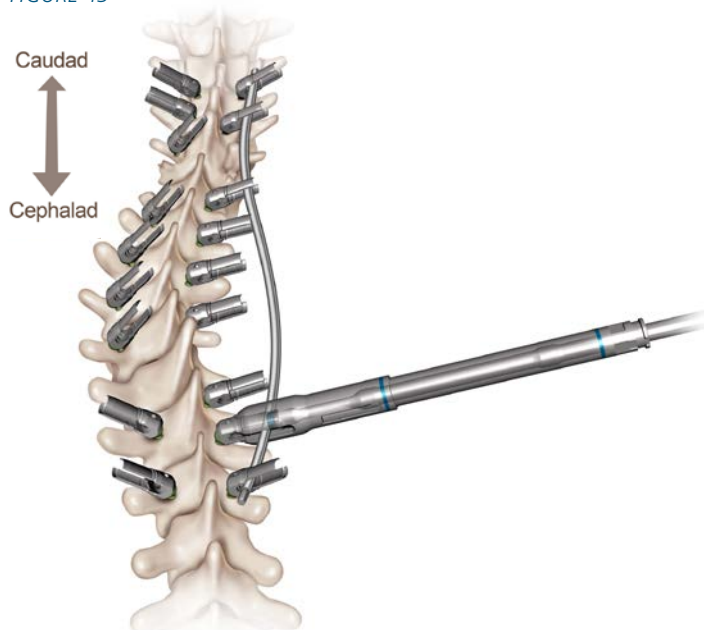

ROD ROTATION

Equipment

2997-04-175	Rod Clamp
2997-04-180	Double End 5.5 Rod Hex Wrench
2997-04-205	VERSE Facilitator
2997-04-220	VERSE Key Inserter/Tightener
2997-04-230	VERSE X25 Inserter/Tightener
2997-04-145	Pencil Handle
2997-04-140	Ratcheting Tear-Drop Handle
2997-04-135	Ratcheting T-Handle

Following rod capture and prior to rod reduction, typically the sagittal contour of the rod is still in the coronal plane. After reducing the rod, a rod rotation maneuver can be performed by aligning the sagittal contour of the rod with the sagittal plane of the patient. This technique will further translate the spine to the rod.

Either the Rod Clamp or the Double End 5.5 Rod Hex Wrench or a combination of both can be applied to the rod to rotate and restore sagittal alignment. In order to reduce the rib prominence, it may help to have an assistant push down on the convex ribs and the convex screws.

Once the rod has been properly oriented in the sagittal plane, the distal or proximal neutral levels can be locked to maintain the new orientation of the rod. This is accomplished by fully reducing these neutral levels by using the VERSE Key Inserter/Tightener assembled to the Torque Limiting Handle and then provisionally tightening the Rod Lock with the VERSE X25 Inserter/Tightener assembled to the Torque Limiting Handle. Following this, the Rod Clamp and/or Double End 5.5 Rod Hex Wrench can be removed.

Continued and incremental reduction across all levels should result in additional translation of the spine while distributing the forces required for correction along the length of the construct.

FIGURE 44

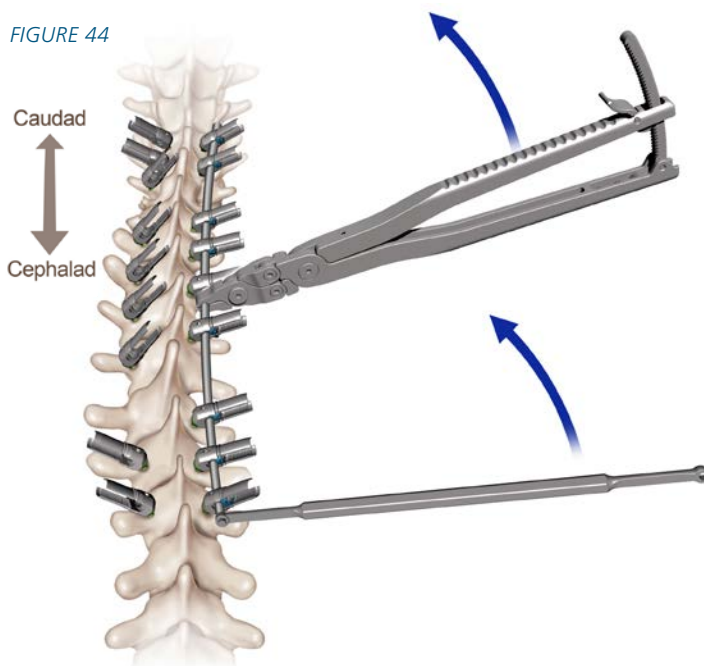
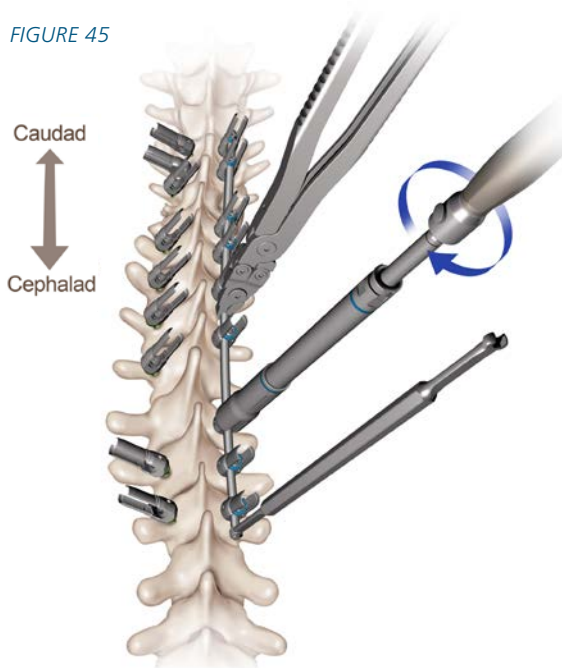

FIGURE 45



NOTE: Reduction or extended tab screws such as EXPEDIUM VERSE Screws provide the additional benefit of accommodating a technique in which the rod is rotated from the coronal to sagittal plane prior to being fully reduced. While this alteration to the traditional rod rotation results in less initial segmental translation of the spine, it reduces the force applied to the rod during this maneuver when compared to rod rotation after fully reducing the rod at all levels. The reduction in force may result in less flattening of the rod.⁶

VERTEBRAL BODY DEROTATION

Equipment

2997-04-220	VERSE Key Inserter/Tightener
2997-04-230	VERSE X25 Inserter/Tightener
2997-04-320	Torque Limiting Handle 80in-lb (9Nm)
2997-04-205	VERSE Facilitator
VERSE Quick Stick Assembly – Comprised of:	
2997-04-215	VERSE Quick Stick Sleeve
2997-04-217	VERSE Quick Stick Tube
2997-04-255	VERSE Counter Torque Handle

Alternative Equipment

2797-52-130	Hook Pusher
2797-88-955	Derotation Quick Stick Frame
2867-37-010	Viper Top Loading Derotation Frame

Significant coronal plane correction can be consistently obtained during scoliosis correction with the use of pedicle screws.^{2,9,10} True axial plane correction can also be achieved to address the rotational deformity of the spine, ribs, and chest wall. The main goal of vertebral body derotation (VBD) is to achieve rotational deformity correction, which may decrease the need for thoracoplasty.

With a traditional instrument based deformity system, a combination of pedicle screw types is required to achieve rotational correction of the deformity. On the concave side, a combination of monoaxial, uniplanar, polyaxial, and reduction screws can be used. On the convex side monoaxial and uniplanar or polyaxial screws are placed into the pedicles.

The EXPEDIUM VERSE Spinal System provides intraoperative conversion of polyaxial screws into monoaxial screws, providing a means to obtain derotational correction with a single implant type. (FIGURE 46)

By tightening the VERSE Correction Key Poly Lock and using Facilitators or VERSE Quick Sticks, vertebral body derotation (VBD) can be performed as for any monoaxial screw. VBD is most effective when done with a single rod attached to the spine or prior to both rods being fully reduced.

The hypermobility or increased angulation of the polyaxial head in combination with the extended tabs enable loose capture of the concave rod allowing the rod to move within the screw head while upward derotation forces are being applied to the concave side and downward derotation forces are being applied to the convex side. Axial correction can be retained by advancing the VERSE Correction Key or VERSE Unitized Set Screws of the concave pedicle screws during application of derotation forces. This technique enables a surgeon to complete derotation in a series of small adjustments without the need to remove or recontour a rod.

VERSE Facilitators and Quick Sticks are available for the application of derotation forces. Facilitators slide over the implant head and provide a lever arm for derotation maneuvers, but are not suitable for rods that are not fully reduced.

VERSE Quick Sticks are locking facilitators which can be applied to the concavity of the apical levels. This instrument will engage the TOP NOTCH Feature of the screw allowing the application of an upward or pulling force during the derotation maneuver. Quick Sticks are also capable of capturing 30mm of total reduction for rods yet to be reduced into the screw head.

FIGURE 46

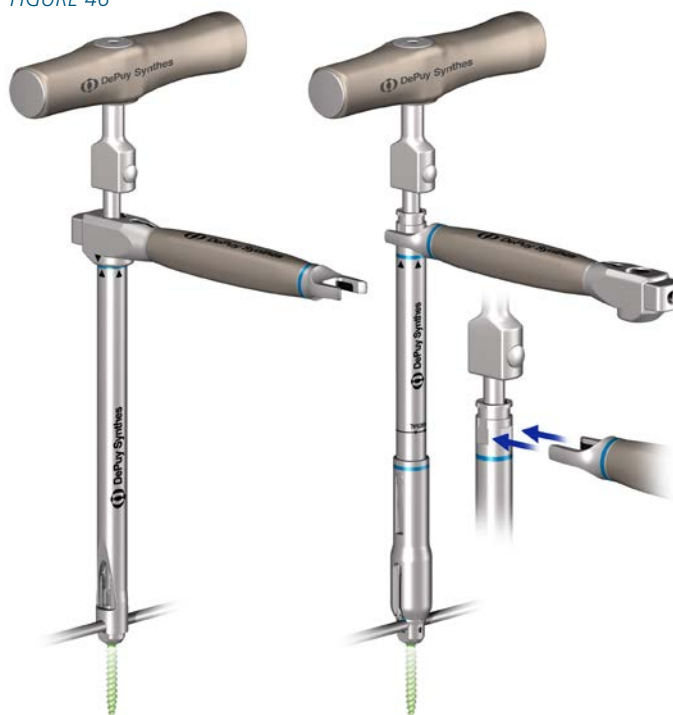

Quick Stick Assembly and Attachment

The VERSE Quick Stick is comprised of two components, a sleeve and a tube. To assemble, align the slots of each component and slide the sleeve onto the distal end of the tube. Once properly aligned, the sleeve will engage the Quick Stick Tube.

With the Quick Stick Sleeve in the retracted position, align the slots of the Quick Stick with the rod slot of the implant. Holding only the Quick Stick Tube, press the instrument onto the implant head. An audible click will indicate that the instrument has engaged the TOP NOTCH Feature. Finally, slide the Quick Stick Sleeve distally to lock the instrument to the implant.

FIGURE 47



FIGURE 48

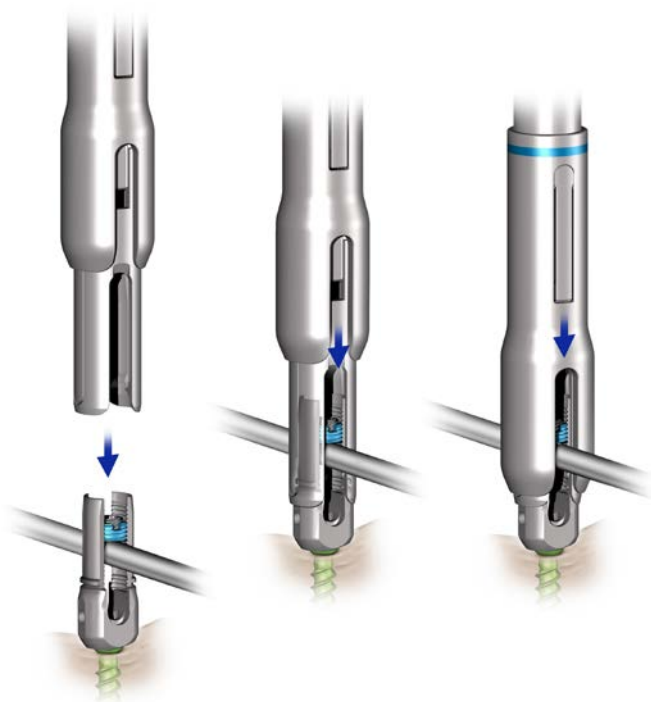

En Bloc Vertebral Body Derotation with the EXPEDIUM VERSE System

Facilitators should be applied to levels requiring derotation following the locking of the polyaxial heads.

If application of a pull force is desired, VERSE Quick Sticks can be attached to the contralateral levels. An assistant pushes down on the convex ribs and the convex screws, while the concave levels are rotated in the direction that will reduce the rib prominence.^{3,8} Application of these push-pull forces should be done simultaneously to distribute stress at the bone-screw interface. The rotation of the concave screws will help decrease the torsion and will lift the concavity out of the chest.

Derotation will bring the concave pedicle screw up to the rod. Reduction of the set screw at this time will retain the achieved derotation. This process should be repeated until the desired degree of derotation is achieved and the rod of the concave pedicles has been fully reduced.

In addition, using the EXPEDIUM Derotation Frame (2797-88-955) (Not in set) multiple Quick Sticks can be linked together and rotated in unison.

FIGURE 49

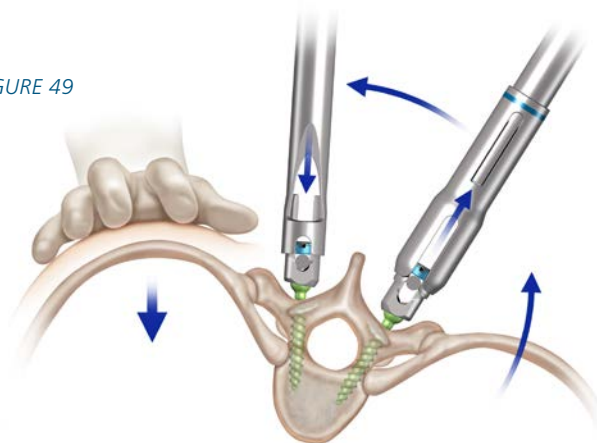
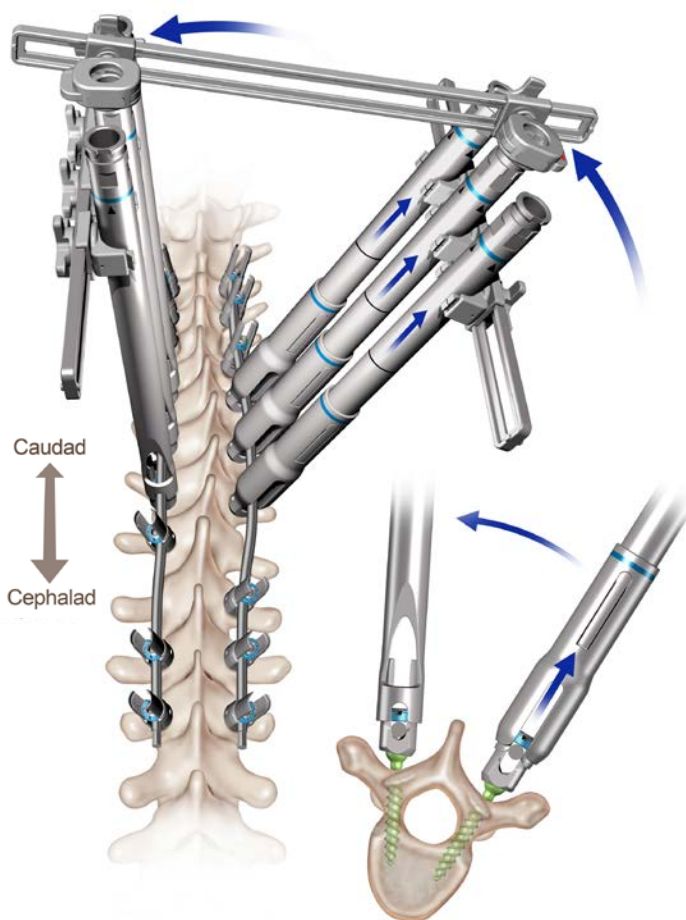

FIGURE 50



Segmental Vertebral Body Derotation with the EXPEDIUM VERSE System

Segmental Vertebral Body Derotation can be done as the sole derotation maneuver or in addition to the en bloc maneuver described previously. There are several methods which can be employed to achieve the desired derotation.

Single Rod Derotation - Temporary Locking of the Convex Screws

Implant the sagittally contoured concave rod and capture it with VERSE Correction Keys or VERSE Unitized Set Screws. Only the VERSE Correction Keys or VERSE Unitized Set Screws in the distal and proximal neutral vertebra should be tightened. Overcontouring of the concave rod can be used to facilitate derotation of the spine.

Once the concave rod is captured (not reduced), lock the distal neutral level EXPEDIUM VERSE Screws. Next, temporarily lock the polyaxial head of the convex screws of the levels requiring derotation. This can be achieved with a short temporary rod segment and a counter torque handle connected to a facilitator or quick stick tube while using the Torque Limiting Handle with the VERSE Key Inserter/Tightener to apply final tightening torque to the Poly Lock at these levels. (FIGURE 51)

Apply facilitators to the distal anchors of the neutral segment. Place another two facilitators on the next proximal level. A Quick Stick should be attached to the concave screw as application of a pull force is required.

Derotate the proximal vertebra to a neutral position and tighten the concave VERSE Correction Key/Unitized Set Screw to retain the derotation. The VERSE Facilitator/Quick Stick on the neutral level should be used to apply a counter force as the rotated segment is corrected to a neutral position. Repeat the previous steps, moving proximally toward the apex.

Once all levels have been derotated and the concave rod is fully reduced, the VERSE Correction Key on the convex screws can be removed to allow placement of the convex rod. If additional derotation is desired, the convex rod can be under contoured. Once both rods are captured, all VERSE Correction Key Poly Locks should be final tightened.

Compression or distraction can be performed segmentally at this point if needed, as the EXPEDIUM VERSE Screws allow for parallel compression/distraction on the rod when the VERSE Correction Key Poly Lock is final tightened and the Rod Lock is loose. Instruction is provided in the Compression and Distraction Section.

FIGURE 51

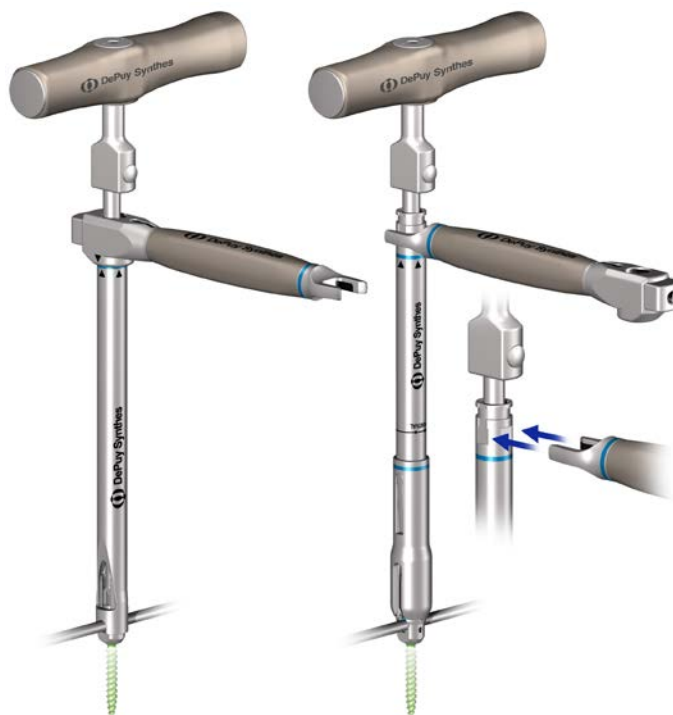
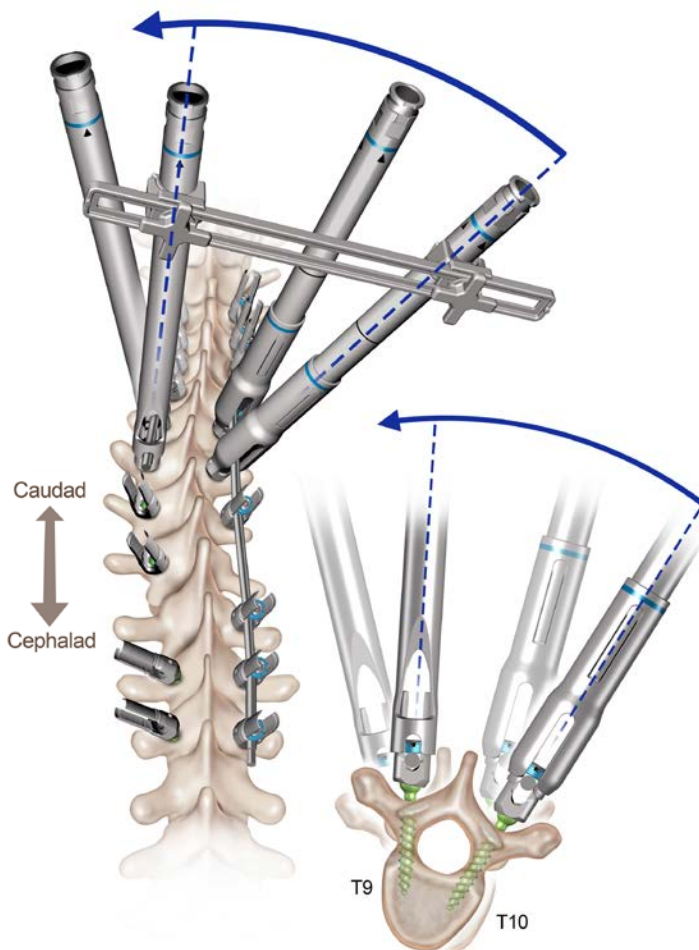

FIGURE 52



Two Rod Derotation

Implant both rods and capture them with either VERSE Correction Keys or VERSE Unitized Set Screws. The convex screws should be converted to monoaxial screws by engaging the VERSE Correction Key's Poly Lock. The VERSE Correction Key's Rod Lock should not be applied since lengthening of the spine is expected at each level that will be segmentally derotated. The pedicle screws of the concave side should not be fully reduced as the derotation maneuver will bring the concave pedicles up to the rod. Only the VERSE Correction Key/Unitized Set Screws in the distal neutral vertebra should be tightened.

Attach VERSE Facilitators or VERSE Quick Sticks to the distal neutral segment. Lock this level by tightening the Poly Lock and then the Rod Lock. Attach a Facilitator to the convex side of the next proximal vertebrae. Attach a VERSE Quick Stick to the contralateral, concave side. The Facilitator/Quick Stick on the neutral level should be used to apply a counter force as the rotated segment is corrected to a neutral position.

The EXPEDIUM Derotation Frame (2797-88-955) can be side mounted to either Facilitators or Quick Sticks of the same vertebral level allowing them to be rotated in unison. Similarly, the Viper Top Loading Derotation Frame (2867-37-010) can be top mounted to the Quick Sticks to provide the same benefit.

Repeat the derotation for each segment, until all vertebral levels nearly match the neutrally rotated distal vertebra.

Once derotation has been achieved and the rods have been fully reduced, segmental compression (convexity) and/or distraction (concavity) may be simultaneously applied to affect maximal correction, just before the Rod Lock is tightened.

If required, additional coronal correction can be achieved with the use of EXPEDIUM Coronal In-Situ Benders.

FIGURE 53

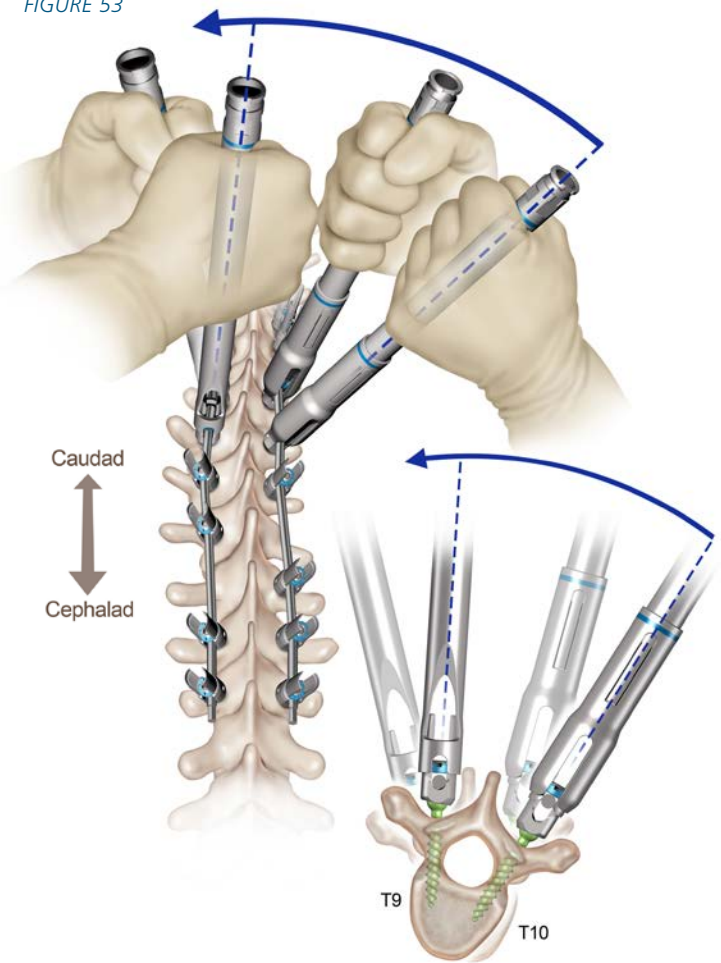

Single Rod Derotation - Rotation Around the Concave Rod

Implant the sagittally contoured concave rod and capture with VERSE Correction Keys or VERSE Unitized Set Screws. Overcontouring of the concave rod can be used to facilitate derotation of the spine. If desired, tightening the VERSE Correction Keys or VERSE Unitized Set Screws in the distal or proximal neutral vertebra can be used to maintain the alignment of the sagittal rod contour with the sagittal plane.

Using a VERSE Facilitator and the VERSE Key Inserter/Tightener assembled to the Pencil Handle, introduce and reduce set screws along the length of the concave rod. Care should be taken to distribute correction forces along the length of the construct. Resistance at any level while reducing indicates that further advancement at an adjacent level or VERSE Correction Key/Unitized Set Screw introduction at another level should occur. Continue this iterative introduction and reduction procedure until the rod has been reduced on the concave side.

Once the concave side is fully reduced, convert all screws to monoaxial implants by final tightening the Poly Lock. Using a counter torque instrument, final tighten the Poly Lock using the Torque Limiting Handle with the VERSE Key Inserter/Tightener.

Final tighten the Rod Locks of the distal neutral level(s).

Apply a facilitator to the next proximal level. Derotate the proximal vertebra while using the neutral level to apply a counter-rotation force. Tighten the Rod Lock of the rotated level to retain the derotation. Repeat the previous steps, moving proximally toward the apex.

Once all levels have been derotated, the convex rod can be placed. If additional derotation is desired, the convex rod can be under contoured. Once both rods are fully reduced, all Poly Locks along the convex rod should be final tightened.

Compression or distraction can be performed segmentally at this point if needed. The EXPEDIUM VERSE Screws allow for parallel compression/distraction on the rod when the Poly Lock is final tightened and the Rod Lock is loose.

FIGURE 54

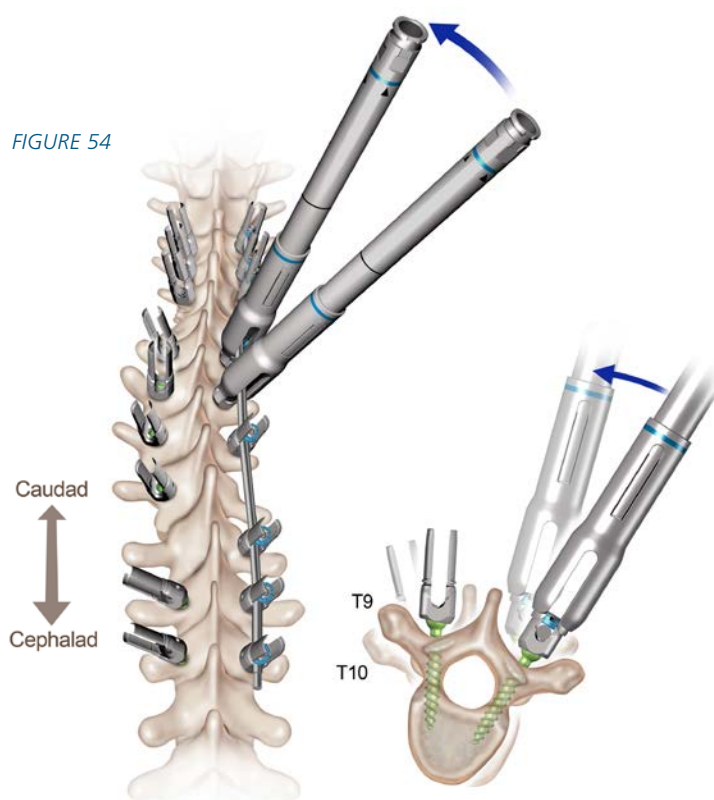

COMPRESSION AND DISTRACTION

Equipment

2997-04-240	Compressor
2997-04-250	Distractor
2997-04-230	VERSE X25 Inserter/Tightener
2997-04-320	VERSE Torque Limiting Handle
2997-04-330	VERSE Key Adjuster

Alternative Equipment

2997-04-135/140	T-Handle/Tear-Drop Handle
2997-04-255	VERSE Counter Torque Handle
2997-04-205	VERSE Facilitator

Once the rod has been captured and reduced in the polyaxial screw heads, compression and distraction maneuvers can be accomplished.

When using VERSE Correction Keys, engagement of the Poly Lock will convert the polyaxial screw to a monoaxial implant maintaining the position of the implant head while allowing for translation of the pedicle screw along the rod.

When revisiting previously locked segments for further manipulation, the VERSE Key Adjuster must be used if loosening of the Rod Lock is required. The VERSE Key Adjuster should be used to apply counter torque to the Poly Lock while loosening the Rod Lock. (FIGURE 58) Insert the VERSE X25 Inserter/Tightener into the VERSE Key Adjuster. Engage the drive feature of the Poly Lock. While applying a counter torque to the Poly Lock, loosen the Rod Lock with the VERSE X25 Inserter/Tightener. Selectively loosen or tighten the Rod Lock and apply compressive or distractive forces with the Compressor or Distractor until desired translation of the implant along the rod is achieved. This step does not obviate the need for final tightening which is described in the next section.

FIGURE 55

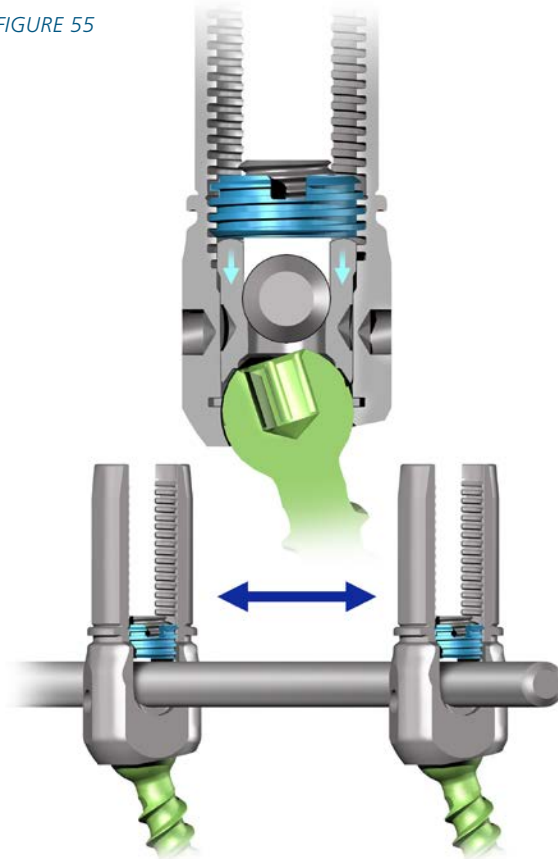
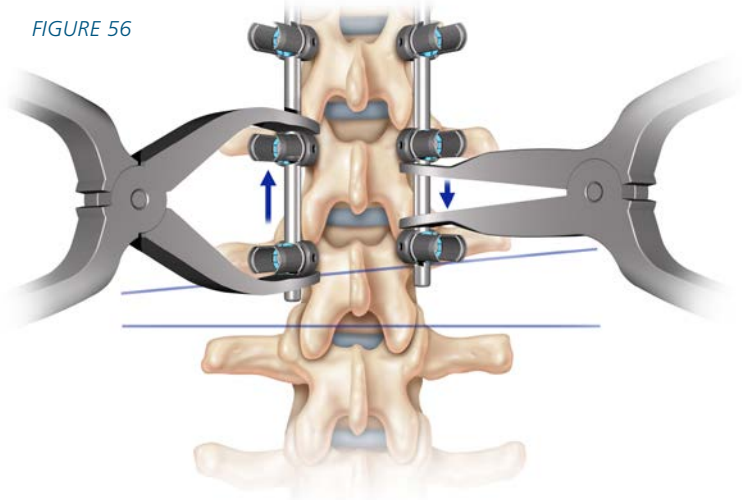

FIGURE 56



Provisionally tighten the Rod Lock to retain the position of the vertebral body.

Optionally, the Rod Lock can also be final tightened at this time using the VERSE Torque Limiting Handle with counter torque instrumentation.

FIGURE 57

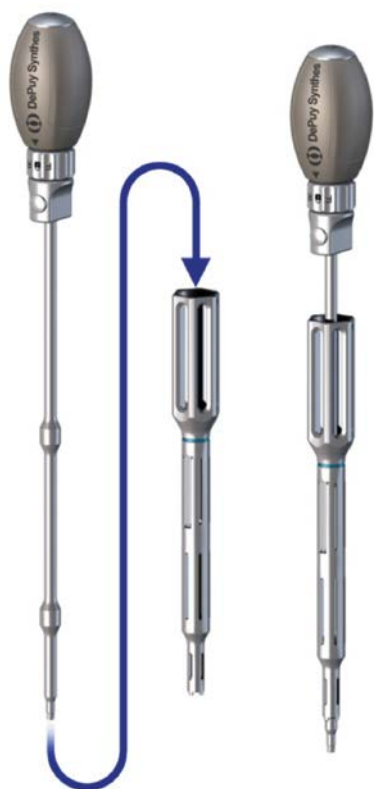
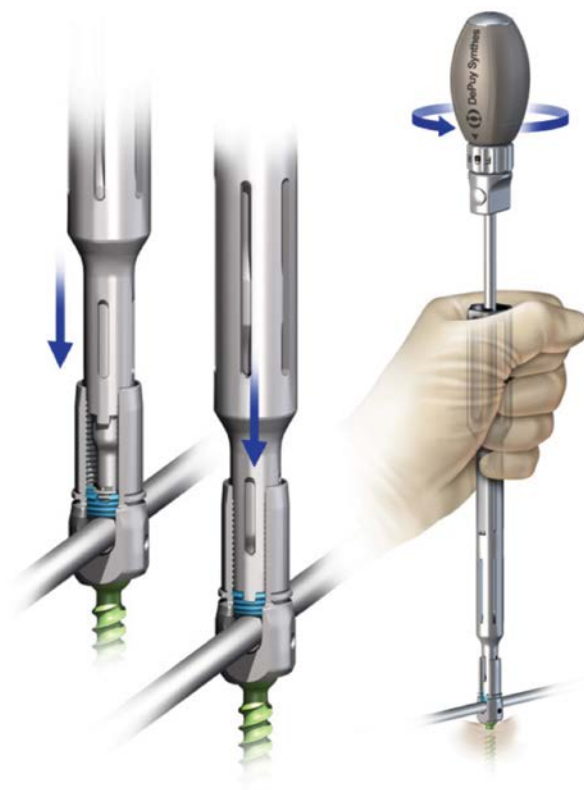

FIGURE 58



FINAL TIGHTENING

Equipment

2997-04-220	VERSE Key Inserter/Tightener
2997-04-230	VERSE X25 Inserter/Tightener
2997-04-320	VERSE Torque Limiting Handle
2997-04-255	VERSE Counter Torque Handle
2997-04-205	VERSE Facilitator

Alternative Equipment

2997-04-325	Torque Handle Adapter, 10mm Hex
2770-40-510	Torque Wrench Handle

Caution: When using VERSE Correction Keys, final tightening of the Poly Lock should always be completed prior to tightening of the Rod Lock. Failure to do so could result in the threads of the VERSE Correction Keys not being fully engaged with pedicle screw head and the VERSE Correction Keys remaining proud.

Final tightening of the Poly Lock is performed with the VERSE Key Inserter/Tightener attached to the Torque Limiting Handle.

FIGURE 59

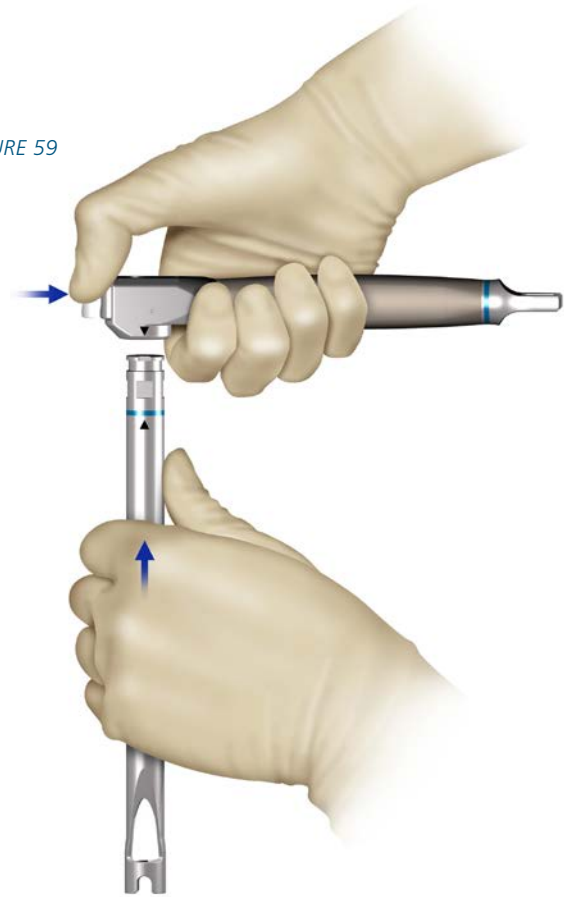

Final tightening of the Rod Lock is performed with the VERSE X25 Inserter/Tightener attached to the Torque Limiting Handle. Final tightening torque for the system is 80in-lb (9Nm).

Assembly of the Counter Torque Handle to a VERSE Facilitator will provide the instrument needed for application of counter force during final tightening. To assemble these instruments, depress the button on the Counter Torque Handle and slide it over the proximal end of a facilitator. The Counter Torque Handle will engage and retain the facilitator. These instruments can be assembled such that the handle will be parallel or perpendicular to the rod. A light pull can be applied to the facilitator to ensure that the Counter Torque Handle has properly engaged and locked the Facilitator.

Place the counter torque assembly over the head of the screw. Insert the VERSE Key Inserter/Tightener or VERSE X25 Inserter/Tightener through the counter torque assembly and engage the corresponding Poly Lock, Rod Lock, or Unitized Set Screw. Tighten until there is a tactile release which indicates that the required 80in-lb (9Nm) of torque has been applied. Repeat this process for all levels.

If required, the Torque Wrench Handle (2770-40-510), found in the EXPEDIUM 5.5 System, can be used with the Torque Handle Adapter (2997-04-325) to final tighten VERSE Correction Keys or Unitized Set Screws.

Caution: Care should be taken to ensure that the Torque Wrench Handle is set to 80in-lb (9Nm).

If a VERSE Correction Key or VERSE Unitized Set Screw needs to be loosened or removed after having been tightened to 80in-lb (9Nm), use the counter torque assembly and VERSE X25 Inserter/Tightener to first loosen the Rod Lock. Then, with the counter torque assembly still in place, use the VERSE Key Inserter/Tightener to loosen the Poly Lock.

FIGURE 60



NOTE: If it is necessary to release the Rod Lock, retighten the Poly Lock prior to retightening the Rod Lock.

TAB REMOVAL

Equipment

2997-04-310	EXPEDIUM Tab Breaker Body
2997-04-315	EXPEDIUM Tab Breaker Cap

A tab remover has been provided for removal of the EXPEDIUM VERSE Screw Reduction Tabs at the completion of the procedure. First, assemble the Tab Breaker by threading the Tab Breaker Cap into the Tab Breaker Body.

(FIGURE 61)

Prior to removing the reduction tabs, ensure that the VERSE Correction Key or VERSE Unitized Set Screw has been fully reduced and tightened. Slide the Tab Breaker over the tab and rock the instrument inward and then outward. (FIGURE 62) Do not twist the instrument during tab removal. Following reduction tab breakage, the instrument can immediately be applied to the next tab.

This instrument has been designed to hold up to 40 tabs. The “full” line provides an indication as to when the reservoir should be emptied prior to proceeding. Additionally, a clearing boss has been provided on the inner side of Tab Breaker Cap. This feature can be inserted into the distal end of the Tab Breaker to clear the last tab removed.

NOTE: It is recommended to keep the tabs in the reservoir from stacking against one another by occasionally shaking the tab breaker while moving from screw to screw

FIGURE 61



FIGURE 62

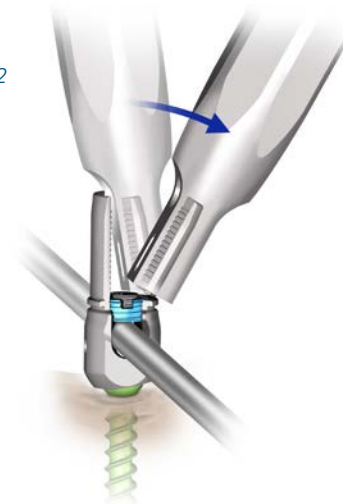

FIGURE 63



REDUCTION WITH FLEX CLIP REDUCER

Equipment

2997-04-220	VERSE Key Inserter/Tightener
2997-04-230	VERSE X25 Inserter/Tightener
2997-04-135/140	T-Handle/Tear-Drop Handle

Flex Clip Reducer Assembly - Comprised of:

2997-04-270	Flex Clip Reducer, Flex Clip
2997-04-272	Flex Clip Reducer, Threaded Insert
2997-04-275	Flex Clip Reducer, Handle

Should screw crowding require the removal of a EXPEDIUM VERSE Screw's extended tabs prior to insertion or a tab prematurely break, a Flex Clip Reducer has been included in the system.

This instrument is comprised of three parts: the Flex Clip, the Threaded Insert (two-part assembly), and the Handle. Start by assembling the two components of the Threaded Insert as shown. (FIGURE 64) Next, compress the proximal end of the Flex Clip to open the distal end. Place over the TOP NOTCH Feature and allow distal end to engage. If the Flex Clip has properly engaged the TOP NOTCH Feature, slight rotational or pulling forces should not displace the instrument.

Next, grasping the hex end of the Threaded Insert, insert it into the Flex Clip. Rotating the Threaded Insert in the clockwise direction will engage the threaded mechanism and translate the component distally. Once the instrument has contacted the rod, place the Flex Clip Reducer Handle onto the hex of the Threaded Insert and rotate clockwise to continue reduction.

Care should be taken to distribute reduction forces by utilizing a staged reduction process which involves incremental reduction across multiple levels.

Markings on the side of the flex clip indicate the amount of reduction required. Once reduction marker is aligned with zero "0" the rod has been fully reduced.

To retain reduction, insert a VERSE Correction Key or VERSE Unitized Set Screw through the Flex Clip Reducer.

The Flex Clip Reducer can be removed by unthreading the Threaded Insert and compressing the Flex Clip to disengage the TOP NOTCH Feature.

FIGURE 64



FIGURE 65

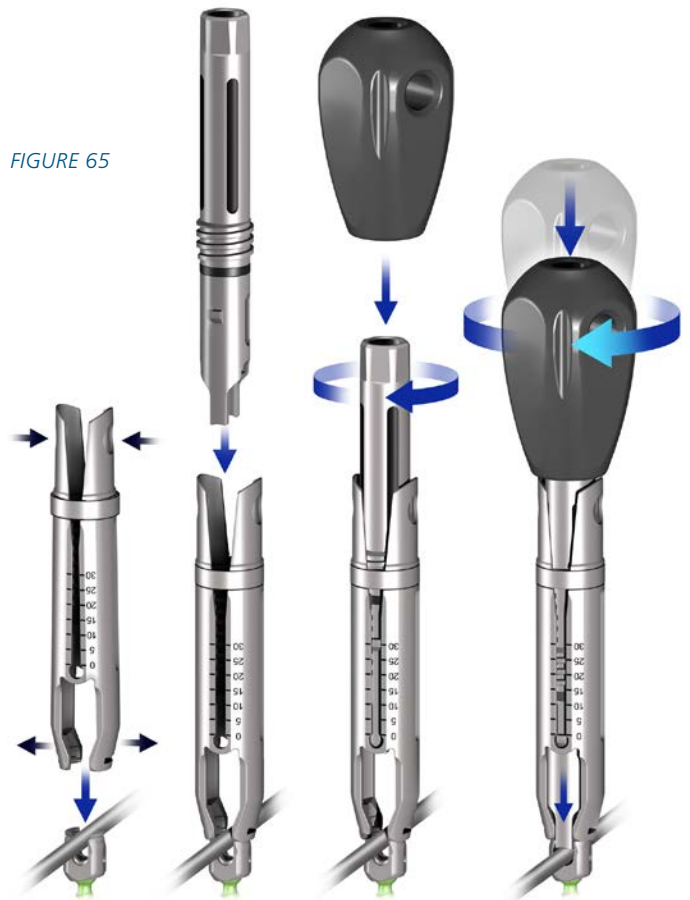

3. PRODUCT CATALOG

TRAY CONTENTS – PEDICLE PREPARATION

Contents

ITEM NUMBER	DESCRIPTION	ITEM NUMBER	DESCRIPTION
2997-04-100	1 Pedicle Awl	2997-04-040	11 4.35mm Double-Lead Tap
2797-02-030	2 Thoracic Pedicle Probe, Straight	2997-04-050	12 5mm Double-Lead Tap
2797-02-040	3 Thoracic Pedicle Probe, Curved	2997-04-060	13 6mm Double-Lead Tap
2997-04-115	4 Lumbar Pedicle Probe, Straight	2997-04-070	14 7mm Double-Lead Tap
2997-04-120	5 Lumbar Pedicle Probe, Curved	2997-04-080	15 8mm Double-Lead Tap
2997-04-125	6 Ball Tip Feeler, Straight	2997-04-940	16 4.35mm Double Lead Tap, Cannulated
2997-04-130	7 Ball Tip Feeler, Curved	2997-04-950	17 5mm Double Lead Tap, Cannulated
2997-04-135	8 T-Handle, Ratcheting	2997-04-960	18 6mm Double Lead Tap, Cannulated
2997-04-145	9 Pencil Handle (x3)	2997-04-970	19 7mm Double Lead Tap, Cannulated
2997-04-140	10 Tear-Drop Handle, Ratcheting (x2)	2997-04-980	20 8mm Double Lead Tap, Cannulated

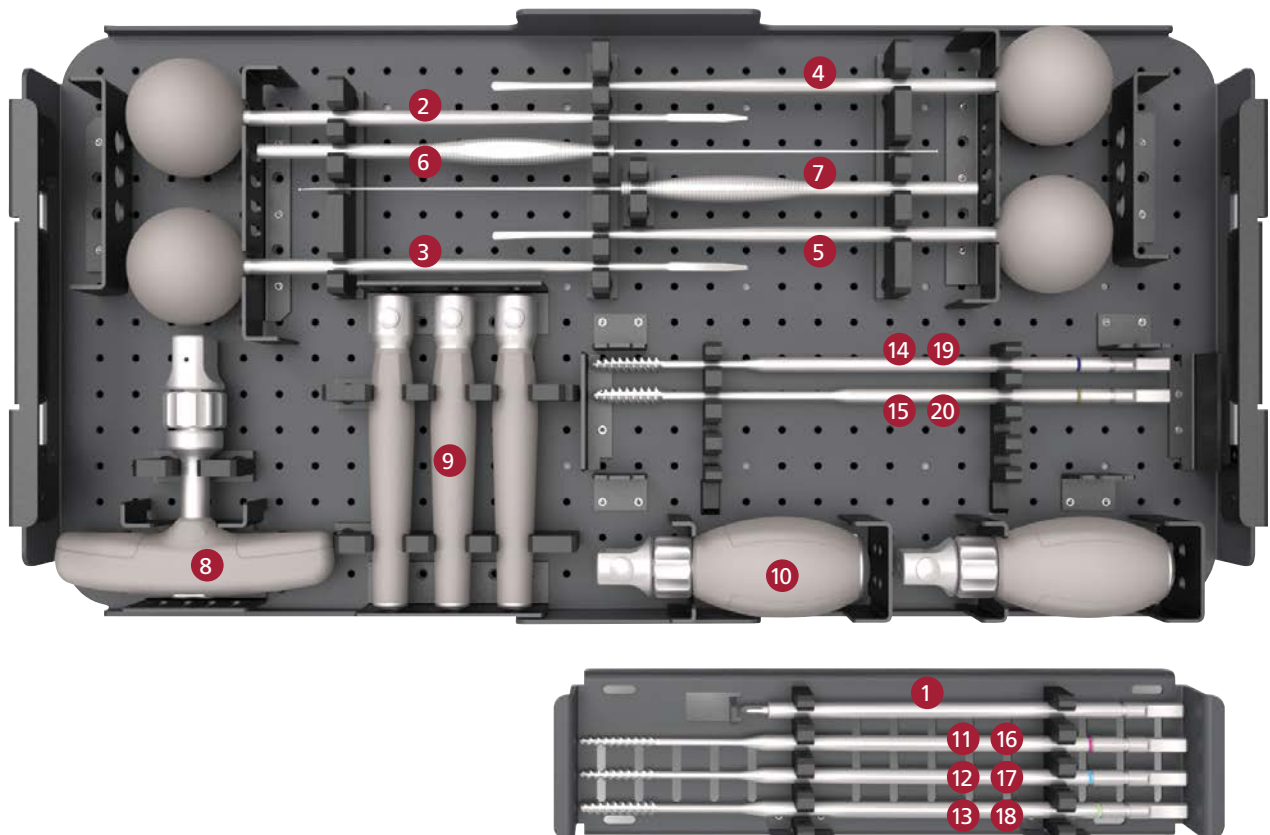

TRAY CONTENTS – SCREW AND ROD INSERTION

Contents

ITEM NUMBER	DESCRIPTION
VERSE Poly Driver Assembly (x2) Comprised of:	
2997-04-152	1 VERSE Poly Driver, Handle (x2)
2997-04-155	2 VERSE Poly Driver, Shaft (x2)
2997-04-160	3 VERSE Poly Driver, Sleeve (x2)
2997-04-165	4 VERSE Head Adjuster
2997-04-180	5 Double End 5.5 Rod Hex Wrench
2997-04-175	6 Rod Clamp 5.5. (x2)
2997-04-330	7 VERSE Key Adjuster

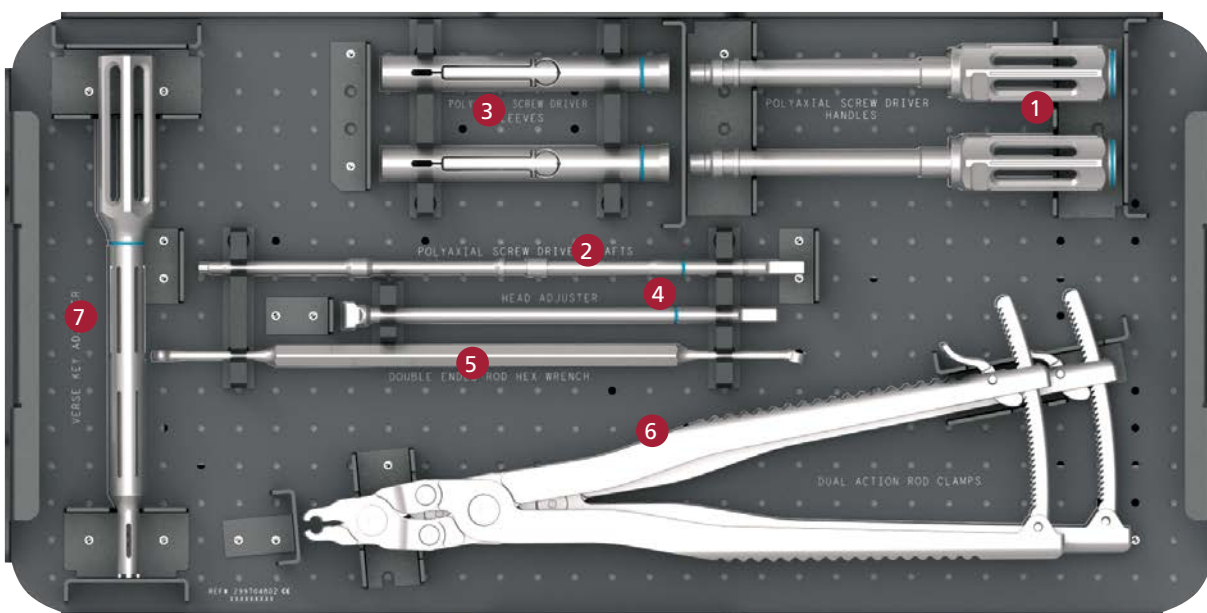

TRAY CONTENTS – REDUCTION AND DEROTATION

Contents

ITEM NUMBER	DESCRIPTION	ITEM NUMBER	DESCRIPTION
VERSE Quick Stick Assembly (x4) Comprised of:			
2997-04-217	1 VERSE Quick Stick Tube (x4)	2997-04-220	6 VERSE Correction Key Inserter/Tightener (x2)
2997-04-215	2 VERSE Quick Stick Sleeve (x4)	2997-04-230	7 VERSE X25 Inserter/Tightener (x2)
Flex Clip Reducer Assembly Comprised of:			
2997-04-270	3 Flex Clip Reducer, Flex Clip	2997-04-205	8 VERSE Facilitator (x6)
2997-04-272	4 Flex Clip Reducer, Threaded Insert (2 piece)	2997-04-355	9 VERSE Tab Ring (x4)
2997-04-275	5 Flex Clip Reducer, Handle		

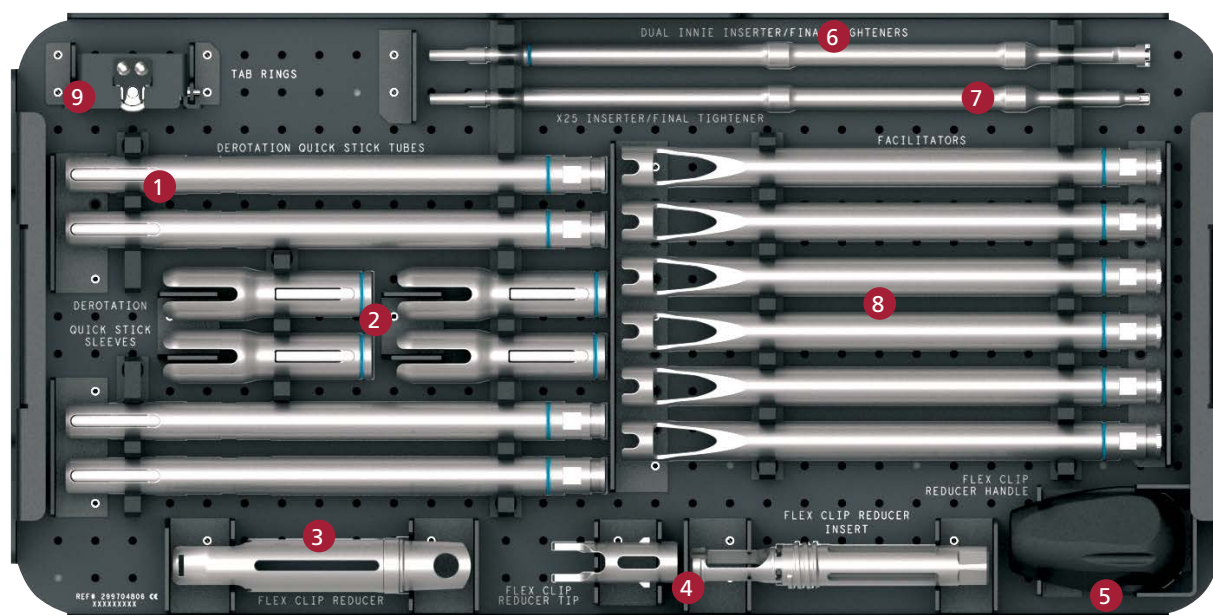

TRAY CONTENTS – COMPRESSION AND DISTRACTION

Contents

ITEM NUMBER	DESCRIPTION
2997-04-320	1 Torque Limiting Handle 80in-lb, (9Nm)
2997-04-325	2 Torque Handle Adapter, 10mm Hex
EXPEDIUM Tab Breaker Assembly Comprised of:	
2997-04-310	3 EXPEDIUM Tab Breaker, Body
2997-04-315	4 EXPEDIUM Tab Breaker, Cap
2997-04-250	5 Distractor, 5.50mm
2997-04-255	6 VERSE Counter Torque Handle
2997-04-240	7 Compressor, 5.50mm

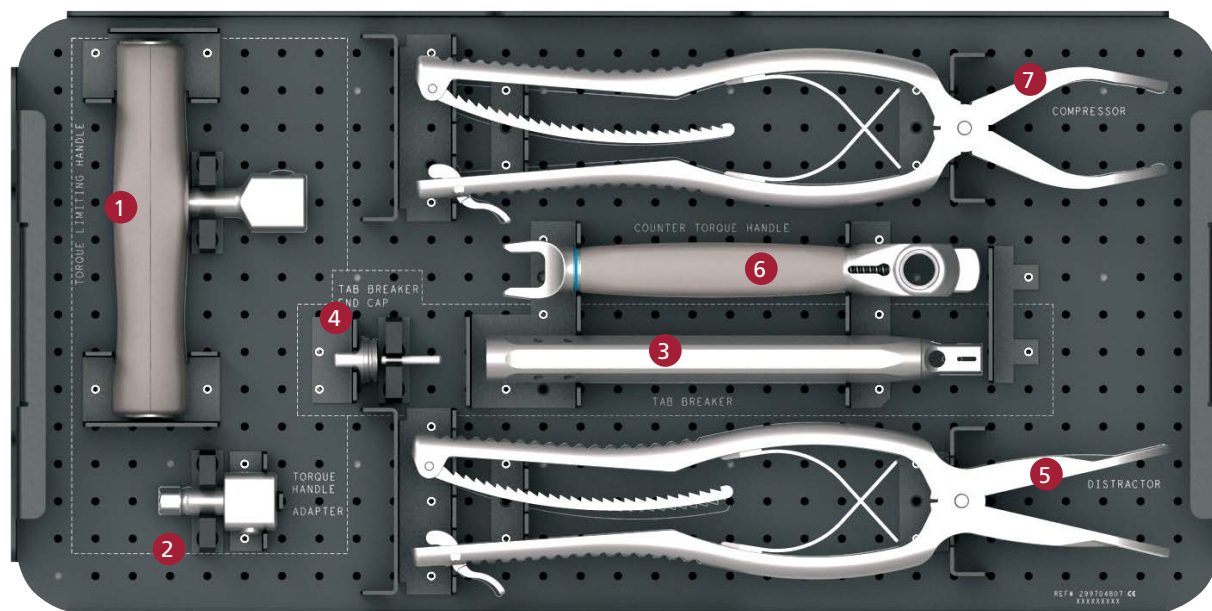

TRAY CONTENTS – ROD BENDING

Contents

ITEM NUMBER	DESCRIPTION
2997-04-185	1 Coronal In-Situ Bender, Left
2997-04-190	2 Coronal In-Situ Bender, Right
2997-04-195	3 Sagittal In-Situ Bender, Left
2997-04-200	4 Sagittal In-Situ Bender, Right
2997-04-170	5 French Rod Bender

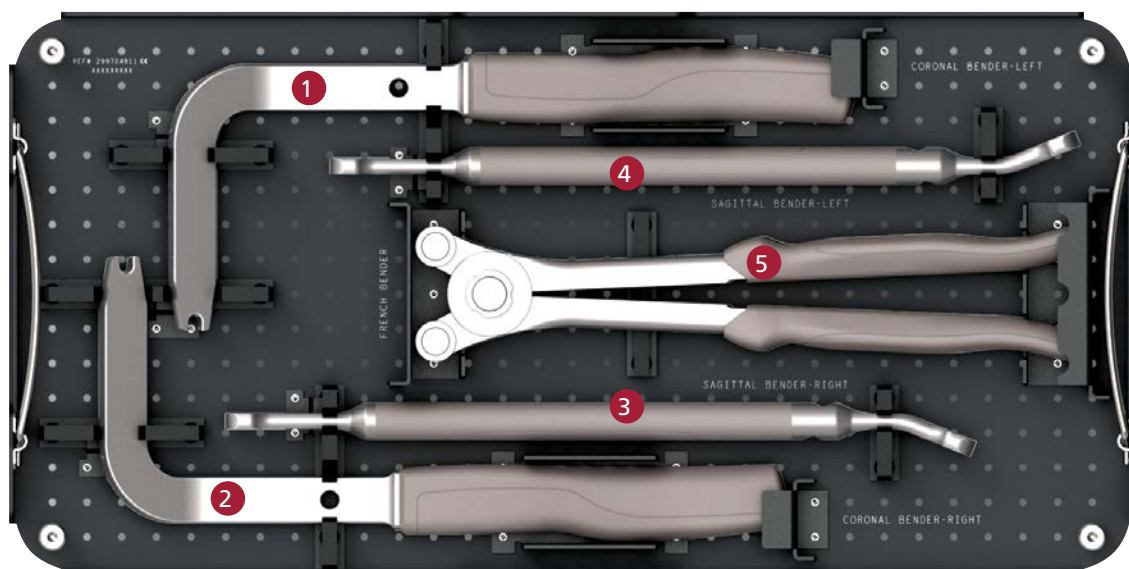

CEMENT DELIVERY

Contents

ITEM NUMBER	DESCRIPTION
2997-04-285	1 VERSE Alignment Device, Open
2997-04-295	2 VERSE Alignment Sleeve, Open
2797-26-402	3 Plunger
2797-26-403	4 Alignment Device Cleaning Stylet
2797-26-511	5 Mini Cleaning Stylet

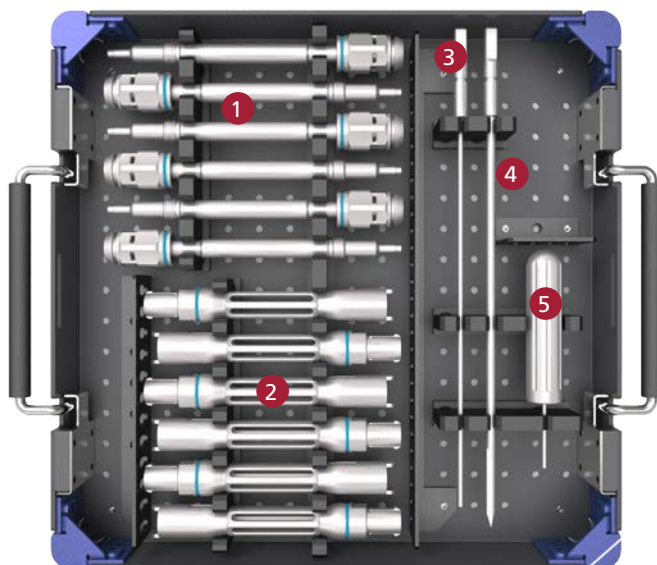

INSTRUMENTS - PEDICLE PREPARATION

Pedicle Awl

ITEM NUMBER	DESCRIPTION	
2997-04-100	Pedicle Awl	





Pedicle Probes

ITEM NUMBER	DESCRIPTION	
2997-04-115	Lumbar Pedicle Probe, Straight	
2997-04-120	Lumbar Pedicle Probe, Curved	





Sounding Probes

ITEM NUMBER	DESCRIPTION	
2997-04-125	Ball Tip Feeler, Straight	
2997-04-130	Ball Tip Feeler, Curved	

Modular Taps





ITEM NUMBER	DESCRIPTION	
2997-04-040	4.35mm Double-Lead Tap	
2997-04-050	5mm Double-Lead Tap	
2997-04-060	6mm Double-Lead Tap	
2997-04-070	7mm Double-Lead Tap	
2997-04-080	8mm Double-Lead Tap	

Modular Taps

ITEM NUMBER	DESCRIPTION	
2997-04-940	4.35mm Double Lead Tap, Cannulated	
2997-04-950	5mm Double Lead Tap, Cannulated	
2997-04-960	6mm Double Lead Tap, Cannulated	
2997-04-970	7mm Double Lead Tap, Cannulated	
2997-04-980	8mm Double Lead Tap, Cannulated	

HANDLES & ADAPTORS

Modular Handles









ITEM NUMBER	DESCRIPTION	
2997-04-135	T-Handle, Ratcheting	
2997-04-140	Tear-Drop Handle, Ratcheting	
2997-04-145	Pencil Handle	
2997-04-320	Torque Limiting Handle, 80in-lb	

Adapters

ITEM NUMBER	DESCRIPTION	
2997-04-325	Torque Handle Adapter, 10mm Hex	

SCREW INSTRUMENTS

Pedicle Screw and Set Screw Insertion

ITEM NUMBER	DESCRIPTION	
VERSE Poly Driver Assembly Comprised of:		
2997-04-152	VERSE Poly Driver, Handle	
2997-04-155	VERSE Poly Driver, Shaft	
2997-04-160	VERSE Poly Driver, Sleeve	
2997-04-165	VERSE Head Adjuster	
2997-04-220	VERSE Key Inserter/Tightener	
2997-04-230	VERSE X25 Inserter/Tightener	
2997-04-255	VERSE Counter Torque Handle	
2997-04-355	VERSE Tab Ring	

ROD REDUCTION AND DEROTATION



ITEM NUMBER	DESCRIPTION	
2997-04-205	VERSE Facilitator	
VERSE Quick Stick, Assembly Comprised of:		
2997-04-215	VERSE Quick Stick, Sleeve	
2997-04-217	VERSE Quick Stick, Tube	
Flex Clip Reducer, Assembly Comprised of:		
2997-04-270	Flex Clip Reducer, Flex Clip	
2997-04-272	Flex Clip Reducer, Threaded Insert	
2997-04-275	Flex Clip Reducer, Handle	

ROD INSTRUMENTS



Rod Holders and Benders

ITEM NUMBER	DESCRIPTION	
2997-04-175	Rod Clamp	
2997-04-180	Double End 5.5 Rod Hex Wrench	
2997-04-170	French Rod Bender	
2997-04-185	Coronal In-Situ Bender, Left	
2997-04-190	Coronal In-Situ Bender, Right	
2997-04-195	Sagittal In-Situ Bender, Left	
2997-04-200	Sagittal In-Situ Bender, Right	







Compression and Distraction

ITEM NUMBER	DESCRIPTION	
2997-04-240	Compressor, 5.50mm	
2997-04-250	Distractor, 5.50mm	
2997-04-330	VERSE Key Adjuster	

TAB REMOVAL

ITEM NUMBER	DESCRIPTION	
EXPEDIUM Tab Breaker Assembly Comprised of:		
2997-04-310	EXPEDIUM Tab Breaker, Body	
2997-04-315	EXPEDIUM Tab Breaker, Cap	

CEMENT DELIVERY INSTRUMENTS

ITEM NUMBER	DESCRIPTION	
2997-04-285	VERSE Alignment Device, Open	
2997-04-295	VERSE Alignment Sleeve, Open	
2797-26-500	Open Cannula (pre-packed sterile/single use)	
2797-26-402	Plunger	
2797-26-403	Alignment Device Cleaning Stylet	
2797-26-511	Mini Cleaning Stylet	

CASES AND TRAYS

ITEM NUMBER

DESCRIPTION

2997-04-800

Graphic Case – VERSE Instrument 1



2997-04-801

VERSE Instrument 1 – Pedicle Prep

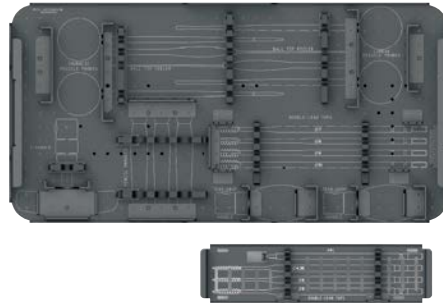

2997-04-802

VERSE Instrument 1 – Screw & Rod Insertion

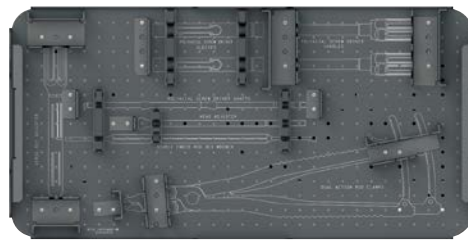

2997-04-805

Graphic Case – VERSE Instrument 2



2997-04-806

VERSE Instrument 2 –
Reduction & Derotation



2997-04-807

VERSE Instrument 2 –
Compression & Distraction

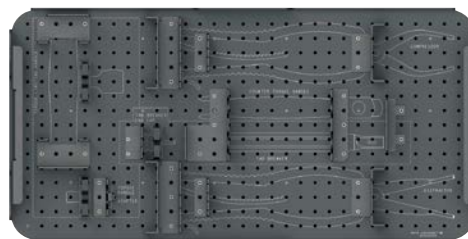

ITEM NUMBER	DESCRIPTION	
2997-04-810	Graphic Case – VERSE Instrument 3	
2997-04-811	VERSE Instrument 3 – Rod Bending	
2997-04-815	Graphic Case – VERSE Implant 1	
2997-04-816	VERSE Implant 1 – Rods, VERSE Keys, and Unitized Set Screws	
2997-04-825	Screw Measuring Template	
2997-04-830	VERSE Key and Unitized Set Screw Caddy	
2797-92-109	Generic Outer Lid	

ITEM NUMBER	DESCRIPTION
-------------	-------------

2997-04-835

Graphic Case –
VERSE Fenestrated Instruments



2997-04-840

Generic Outer Half Lid



2997-04-845

Graphic Case –
VERSE Fenestrated Implant 1

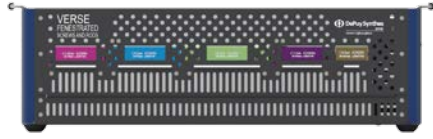

2797-92-109

Generic Outer Lid

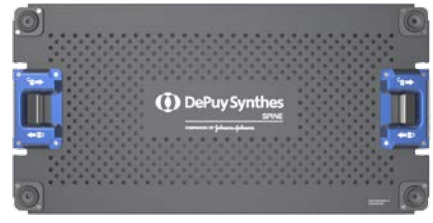

IMPLANTS

ITEM NUMBER	DESCRIPTION
199723430	5.5 EXP VERSE FEN SCR 4.35X30
199723435	5.5 EXP VERSE FEN SCR 4.35X35
199723440	5.5 EXP VERSE FEN SCR 4.35X40
199723445	5.5 EXP VERSE FEN SCR 4.35X45
199723450	5.5 EXP VERSE FEN SCR 4.35X50
199723455	5.5 EXP VERSE FEN SCR 4.35X55
199723460	5.5 EXP VERSE FEN SCR 4.35X60
199723465	5.5 EXP VERSE FEN SCR 4.35X65
199723470	5.5 EXP VERSE FEN SCR 4.35X70
199723475	5.5 EXP VERSE FEN SCR 4.35X75
199723480	5.5 EXP VERSE FEN SCR 4.35X80
199723530	5.5 EXP VERSE FEN SCR 5.0X30
199723535	5.5 EXP VERSE FEN SCR 5.0X35
199723540	5.5 EXP VERSE FEN SCR 5.0X40
199723545	5.5 EXP VERSE FEN SCR 5.0X45
199723550	5.5 EXP VERSE FEN SCR 5.0X50
199723555	5.5 EXP VERSE FEN SCR 5.0X55
199723560	5.5 EXP VERSE FEN SCR 5.0X60
199723565	5.5 EXP VERSE FEN SCR 5.0X65
199723570	5.5 EXP VERSE FEN SCR 5.0X70
199723575	5.5 EXP VERSE FEN SCR 5.0X75
199723580	5.5 EXP VERSE FEN SCR 5.0X80



ITEM NUMBER	DESCRIPTION
199723630	5.5 EXP VERSE FEN SCR 6.0X30
199723635	5.5 EXP VERSE FEN SCR 6.0X35
199723640	5.5 EXP VERSE FEN SCR 6.0X40
199723645	5.5 EXP VERSE FEN SCR 6.0X45
199723650	5.5 EXP VERSE FEN SCR 6.0X50
199723655	5.5 EXP VERSE FEN SCR 6.0X55
199723660	5.5 EXP VERSE FEN SCR 6.0X60
199723665	5.5 EXP VERSE FEN SCR 6.0X65
199723670	5.5 EXP VERSE FEN SCR 6.0X70
199723675	5.5 EXP VERSE FEN SCR 6.0X75
199723680	5.5 EXP VERSE FEN SCR 6.0X80
199723730	5.5 EXP VERSE FEN SCR 7.0X30
199723735	5.5 EXP VERSE FEN SCR 7.0X35
199723740	5.5 EXP VERSE FEN SCR 7.0X40
199723745	5.5 EXP VERSE FEN SCR 7.0X45
199723750	5.5 EXP VERSE FEN SCR 7.0X50
199723755	5.5 EXP VERSE FEN SCR 7.0X55
199723760	5.5 EXP VERSE FEN SCR 7.0X60
199723765	5.5 EXP VERSE FEN SCR 7.0X65
199723770	5.5 EXP VERSE FEN SCR 7.0X70
199723775	5.5 EXP VERSE FEN SCR 7.0X75
199723780	5.5 EXP VERSE FEN SCR 7.0X80



ITEM NUMBER	DESCRIPTION
199723830	5.5 EXP VERSE FEN SCR 8.0X30
199723835	5.5 EXP VERSE FEN SCR 8.0X35
199723840	5.5 EXP VERSE FEN SCR 8.0X40
199723845	5.5 EXP VERSE FEN SCR 8.0X45
199723850	5.5 EXP VERSE FEN SCR 8.0X50
199723855	5.5 EXP VERSE FEN SCR 8.0X55
199723860	5.5 EXP VERSE FEN SCR 8.0X60
199723865	5.5 EXP VERSE FEN SCR 8.0X65
199723870	5.5 EXP VERSE FEN SCR 8.0X70
199723875	5.5 EXP VERSE FEN SCR 8.0X75
199723880	5.5 EXP VERSE FEN SCR 8.0X80





ITEM NUMBER	DESCRIPTION
1997-21-420	5.5 Ti EXP VERSE SCREW 4.35X20
1997-21-425	5.5 Ti EXP VERSE SCREW 4.35X25
1997-21-430	5.5 Ti EXP VERSE SCREW 4.35X30
1997-21-435	5.5 Ti EXP VERSE SCREW 4.35X35
1997-21-440	5.5 Ti EXP VERSE SCREW 4.35X40
1997-21-445	5.5 Ti EXP VERSE SCREW 4.35X45
1997-21-450	5.5 Ti EXP VERSE SCREW 4.35X50
1997-21-455	5.5 Ti EXP VERSE SCREW 4.35X55
1997-21-460	5.5 Ti EXP VERSE SCREW 4.35X60
1997-21-465	5.5 Ti EXP VERSE SCREW 4.35X65
1997-21-520	5.5 Ti EXP VERSE SCREW 5.0X20
1997-21-525	5.5 Ti EXP VERSE SCREW 5.0X25
1997-21-530	5.5 Ti EXP VERSE SCREW 5.0X30
1997-21-535	5.5 Ti EXP VERSE SCREW 5.0X35
1997-21-540	5.5 Ti EXP VERSE SCREW 5.0X40
1997-21-545	5.5 Ti EXP VERSE SCREW 5.0X45
1997-21-550	5.5 Ti EXP VERSE SCREW 5.0X50
1997-21-555	5.5 Ti EXP VERSE SCREW 5.0X55
1997-21-560	5.5 Ti EXP VERSE SCREW 5.0X60
1997-21-565	5.5 Ti EXP VERSE SCREW 5.0X65



ITEM NUMBER	DESCRIPTION
1997-21-620	5.5 Ti EXP VERSE SCREW 6.0X20
1997-21-625	5.5 Ti EXP VERSE SCREW 6.0X25
1997-21-630	5.5 Ti EXP VERSE SCREW 6.0X30
1997-21-635	5.5 Ti EXP VERSE SCREW 6.0X35
1997-21-640	5.5 Ti EXP VERSE SCREW 6.0X40
1997-21-645	5.5 Ti EXP VERSE SCREW 6.0X45
1997-21-650	5.5 Ti EXP VERSE SCREW 6.0X50
1997-21-655	5.5 Ti EXP VERSE SCREW 6.0X55
1997-21-660	5.5 Ti EXP VERSE SCREW 6.0X60
1997-21-665	5.5 Ti EXP VERSE SCREW 6.0X65
1997-21-720	5.5 Ti EXP VERSE SCREW 7.0X20
1997-21-725	5.5 Ti EXP VERSE SCREW 7.0X25
1997-21-730	5.5 Ti EXP VERSE SCREW 7.0X30
1997-21-735	5.5 Ti EXP VERSE SCREW 7.0X35
1997-21-740	5.5 Ti EXP VERSE SCREW 7.0X40
1997-21-745	5.5 Ti EXP VERSE SCREW 7.0X45
1997-21-750	5.5 Ti EXP VERSE SCREW 7.0X50
1997-21-755	5.5 Ti EXP VERSE SCREW 7.0X55
1997-21-760	5.5 Ti EXP VERSE SCREW 7.0X60
1997-21-765	5.5 Ti EXP VERSE SCREW 7.0X65



ITEM NUMBER	DESCRIPTION	
1997-21-830	5.5 Ti EXP VERSE SCREW 8.0X30	
1997-21-835	5.5 Ti EXP VERSE SCREW 8.0X35	
1997-21-840	5.5 Ti EXP VERSE SCREW 8.0X40	
1997-21-845	5.5 Ti EXP VERSE SCREW 8.0X45	
1997-21-850	5.5 Ti EXP VERSE SCREW 8.0X50	
1997-21-855	5.5 Ti EXP VERSE SCREW 8.0X55	
1997-21-860	5.5 Ti EXP VERSE SCREW 8.0X60	
1997-21-865	5.5 Ti EXP VERSE SCREW 8.0X65	
1997-21-870	5.5 Ti EXP VERSE SCREW 8.0X70	
1997-21-875	5.5 Ti EXP VERSE SCREW 8.0X75	
1997-21-880	5.5 Ti EXP VERSE SCREW 8.0X80	
1997-21-885	5.5 Ti EXP VERSE SCREW 8.0X85	
1997-21-890	5.5 Ti EXP VERSE SCREW 8.0X90	
1997-21-895	5.5 Ti EXP VERSE SCREW 8.0X95	
1997-21-899	5.5 Ti EXP VERSE SCREW 8.0X100	
1997-21-000	EXP VERSE CORRECTION KEY	
1997-21-001	EXP VERSE UNITIZED SET SCREW	
1797-62-480	Straight Rod, Hex End, Ti 480mm	
1967-89-480	Straight Rod, Viper and Hex Ends, CoCr 480mm	



4. APPENDIX

Titanium Alloy

ELEMENT	MINIMUM %	MAXIMUM %
Nitrogen	—	0.05
Carbon	—	0.08
Hydrogen	—	0.012
Iron	—	0.25
Oxygen	—	0.13
Aluminum	5.5	6.5
Vanadium	3.5	4.5
Titanium	Balance	

Cobalt Chromium Alloy

ELEMENT	MINIMUM %	MAXIMUM %
Carbon	—	0.14
Aluminum	—	—
Lanthanum	—	—
Chromium	26	30
Molybdenum	5	7
Nickel	—	1
Iron	—	0.75
Silicon	—	1
Manganese	—	1
Nitrogen	—	0.25
Cobalt	Balance	

5. USAGE

WARNING: The safety and effectiveness of pedicle screw spinal systems have been established only for spinal conditions with significant mechanical instability or deformity requiring fusion with instrumentation. These conditions are significant mechanical instability or deformity of the thoracic, lumbar, and sacral spine secondary to severe spondylolisthesis (grades 3 and 4) of the L5-S1 vertebra, degenerative spondylolisthesis with objective evidence of neurologic impairment, fracture, dislocation, scoliosis, kyphosis, spinal tumor, and failed previous fusion (pseudarthrosis). The safety and effectiveness of these devices for any other conditions are unknown.

PRECAUTION: The implantation of pedicle screw spinal systems should be performed only by experienced spinal surgeons with specific training in the use of this pedicle screw spinal system because this is a technically demanding procedure presenting a risk of serious injury to the patient.

The surgeon must be thoroughly knowledgeable not only in the medical and surgical aspects of the implant, but must also be aware of the mechanical and metallurgical limitations of metallic surgical implants. Postoperative care is extremely important. The patient must be instructed in the limitations of the metallic implant and be warned regarding weight bearing and body stresses on the appliance prior to firm bone healing. The patient should be warned that noncompliance with postoperative instructions could lead to failure of the implant and possible need thereafter for additional surgery to remove the device.

Refer to the individual system surgical technique manuals for additional important information.

DePuy Spine Spinal System components should not be used with components from other manufacturers.

Stainless steel components may interfere with the quality of imaging obtained using MRI.

During the surgical procedure, the rods may be cut to size and shaped to provide correction and maintain proper anatomic lordotic and kyphotic alignment.

When using anterior thoracic/lumbar screw fixation systems, staples, staple washers and washers are available to optimize proper staple/screw/rod alignment and stability.

Screw diameters of 11mm and 12mm are indicated for use only in the sacrum or ilium. Pre-operative use of CT imaging to determine the appropriate screw diameter, length, insertion trajectory, and clearance is strongly recommended when large diameter screws are indicated.

After solid fusion occurs, these devices serve no functional purpose and may be removed. In some cases, removal is indicated because the implants are not intended to transfer or to support forces developed during normal activities. Any decision to remove the device must be made by the physician and the patient taking into consideration the patient's general medical condition and the potential risk to the patient of a second surgical procedure.

These devices are not intended or expected to be the only mechanism for support of the spine. Regardless of the etiology of the spinal pathology, for which implantation of these devices was chosen, it is the expectation and requirement that a spinal fusion or arthrodesis be planned and obtained. Without solid biological support provided by spinal fusion, the devices cannot be expected to support the spine indefinitely and will fail in any of several modes. These modes may include bone-metal interface failure, implant fracture, or bone failure.

6. POSTOPERATIVE MOBILIZATION

Until X-rays confirm the maturation of the fusion mass, external immobilization (such as bracing or casting) is recommended.

Instructions to the patient to reduce stress on the implants are an equally important part of the attempt to avoid the occurrence of clinical problems that may accompany fixation failure.

7. CONTRAINDICATIONS

Disease conditions that have been shown to be safely and predictably managed without the use of internal fixation devices are relative contraindications to the use of these devices.

Active systemic infection or infection localized to the site of the proposed implantation are contraindications to implantation. Severe osteoporosis is a relative contraindication because it may prevent adequate fixation of spinal anchors and thus preclude the use of this or any other spinal instrumentation system.

Any entity or condition that totally precludes the possibility of fusion, i.e., cancer, kidney dialysis, or osteopenia is a relative contraindication. Other relative contraindications include

obesity, certain degenerative diseases, and foreign body sensitivity. In addition, the patient's occupation or activity level or mental capacity may be relative contraindications to this surgery. Specifically, patients who because of their occupation or lifestyle, or because of conditions such as mental illness, alcoholism, or drug abuse, may place undue stresses on the implant during bony healing and may be at higher risk for implant failure. See also the WARNINGS, PRECAUTIONS AND POSSIBLE ADVERSE EFFECTS CONCERNING TEMPORARY METALLIC INTERNAL FIXATION DEVICES section of this insert.

Please refer to EXPEDIUM VERSE IFU for complete listing of warnings, contraindications, and precautions.

8. REFERENCES

1. D. Crandall, M. M. (2004). Scoliosis correction using a new screw with a pivoting reduction post: biomechanical testing and 2 year clinical results. *Spine Journal*, 4(5), S73-S74.
2. Delorme S, L. H. (1999). Intraoperative comparison of two instrumentation techniques for the correction of adolescent idiopathic scoliosis. *Spine*, 24, 2011–2018.
3. Di Silvestre M, L. F. (2013, February). Apical vertebral derotation in the posterior treatment of adolescent idiopathic scoliosis: myth or reality? *Eur Spine J*, 313-323.
4. Driscoll M, M.-T. J. (2015) Biomechanical Comparison of 2 Different Pedicle Screw Systems During the Surgical Correction of Adult Spinal Deformities. *Spine Deformity*, 3, 114-121.
5. Driscoll, M. M.-T. (2012). Biomechanical Assessment of Favored Angle Screws with Reduction Tabs and Polyaxial Screws during Scoliosis Correction. S.19th International Meeting on Advanced Spine Techniques (IMAST). Istanbul, Turkey.
6. Driscoll, M. M.-T. (2013). Biomechanical Assessment of Reduction Forces Measured During Scoliotic Instrumentation Using Two Different Screw Designs. *Spine Deformity*, 94-101.
7. F. Geiger. (2009, September). More options in scoliosis patients with the Dual Innie Favored Angle Reduction Tab Screw. *ArgoSpine News & Journal*, 21(3), 102-105.
8. Lee, S.-M. S.-I.-R. (2004, February). Direct Vertebral Rotation: A New Technique of Three-Dimensional Deformity Correction With Segmental Pedicle Screw Fixation in Adolescent Idiopathic Scoliosis. *Spine*, 29(3), 343-349.
9. Suk S, L. C. (1995). Segmental pedicle screw fixation in the treatment of thoracic idiopathic scoliosis. *Spine*, 20, 1399–1405.
10. Suk SI, L. C. (1994). Comparison of Cotrel-Dubousset pedicle screws and hooks in the treatment of idiopathic scoliosis. *Int Orthop*, 18, 341–346.
11. Wang X, A. C. (2011, July). Biomechanical modeling and analysis of a direct incremental segmental translation system for the instrumentation of scoliotic deformities. *Clinical Biomechanics*, 26(6), 548–555.
12. Liu, R, Y. B. (2012, August). A Method for Assessing Axial Vertebral Rotation Based on Differential Rod Curvature on the Lateral Radiograph. *Spine*, 37(18), E1120-E1125.

INDICATIONS FOR EXPEDIUM VERSE

EU INDICATIONS

The EXPEDIUM VERSE Spine Systems are intended to provide immobilization and stabilization of spinal segments in skeletally mature patients as an adjunct to fusion in the treatment of acute and chronic instabilities or deformities of the thoracic, lumbar and sacral spine.

The EXPEDIUM VERSE Spine System is intended for noncervical pedicle fixation and nonpedicle fixation for the following indications: degenerative disc disease (defined as back pain of discogenic origin with degeneration of the disc confirmed by history and radiographic studies); spondylolisthesis; trauma (i.e., fracture or dislocation); spinal stenosis; curvatures (i.e., scoliosis, kyphosis, and/or lordosis); tumor, pseudoarthrosis; and failed previous fusion in skeletally mature patients.

When used in a posterior percutaneous approach with MIS instrumentation, the EXPEDIUM VERSE System is intended for noncervical pedicle fixation and nonpedicle fixation for the following indications: degenerative disc disease (defined as back pain of discogenic origin with degeneration of the disc confirmed by history and radiographic studies); spondylolisthesis; trauma (i.e., fracture or dislocation); spinal stenosis; curvatures (i.e., scoliosis, kyphosis, and/or lordosis); tumor, pseudoarthrosis; and failed previous fusion in skeletally mature patients.

When used for posterior non-cervical pedicle screw fixation in pediatric patients, the EXPEDIUM VERSE System metallic implants are indicated as an adjunct to fusion to treat adolescent idiopathic scoliosis. The EXPEDIUM VERSE systems are intended to be used with autograft and/or allograft. Pediatric pedicle screw fixation is limited to a posterior approach

INDICATIONS FOR USE

The EXPEDIUM™ Fenestrated Screw System is intended to be used with the CONFIDENCE SPINAL CEMENT SYSTEM™ or the V-MAX™ Mixing and Delivery System and the VERTEBROPLASTIC® Radiopaque Resinous Material to provide immobilization and stabilization of spinal segments in the treatment of acute and chronic instabilities or deformities of the thoracic, lumbar and sacral spine in patients with diminished bone quality (e.g., osteoporosis, osteopenia, metastatic disease). It is intended to provide temporary internal support and fixation while fusion mass is consolidating or fracture is healing, or for the palliative reconstruction of the tumor patients.



For recognized manufacturer, refer to product label.

DePuy Spine Inc.
325 Paramount Drive
Raynham, MA 02767
USA

Medos International SARL
Chemin-Blanc 38
2400 Le Locle
Switzerland

EC REP

DePuy International, Ltd.
St Anthony's Road
Leeds
LS11 8DT
United Kingdom

Synthes GmbH
Eimattstrasse 3
4436 Oberdorf
Switzerland
Tel: +41 61 965 61 11
Fax: +41 61 965 66 00
www.depuySynthes.com



This publication is not intended for distribution in the USA.

© DePuy Synthes Spine, a division of Synthes GmbH, 2015. All rights reserved.
DSEM/SPN/0915/0337 11/15

