

Avenue[®] L Lateral Lumbar Cage

 with
VerteBRIDGE[®]
PLATING TECHNOLOGY

Surgical Technique

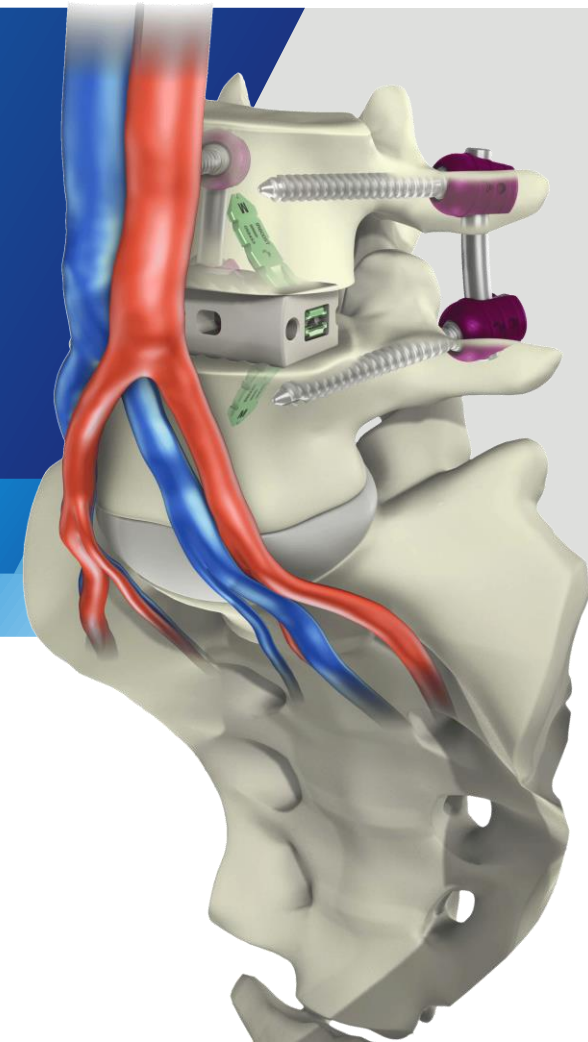

Avenue[®] L

Lateral Lumbar Cage

Indication (United States)

The Avenue L Lateral Lumbar Cage system is indicated for intervertebral body fusion of the lumbar spine, from L2 to S1, in skeletally mature patients who have had six months of non-operative treatment. The device is intended for use at either one level or two contiguous levels for the treatment of degenerative disc disease (DDD) with up to Grade I spondylolisthesis. DDD is defined as back pain of discogenic origin with degeneration of the disc confirmed by history and radiographic studies. The device system is designed for use with or without integrated fixation and must be used in conjunction with posterior supplemental fixation (e.g. pedicle screws). The device system is intended to be used with autograft and/or allogenic bone graft composed of cancellous and/or corticocancellous bone graft to facilitate fusion.

Note: VerteBRIDGE[®] Plating is the integrated fixation designed specifically for the Avenue L cage. Additional supplemental fixation options must be used with the Avenue L cage (with or without VerteBRIDGE[®] Plating) which may include posterior pedicle systems or other posterior fusion systems cleared by the FDA.

LDR, a division of Zimmer Biomet Spine, does not practice medicine. Each physician should exercise his or her own independent judgment in the diagnosis and treatment of an individual patient, and this information does not purport to replace the comprehensive training physicians have received.

Discectomy & Endplate Preparation

- Once the desired disc space is reached, a Penfield is used to sweep the residual muscle off of the disc space. To begin the discectomy, incise the annulus using a bayoneted knife. The Cobb Elevator is then used to separate the disc from the upper and lower end plates. It may be necessary to gently mallet the Cobb Elevator in order to fully release the superior and inferior aspects of the contralateral annulus.

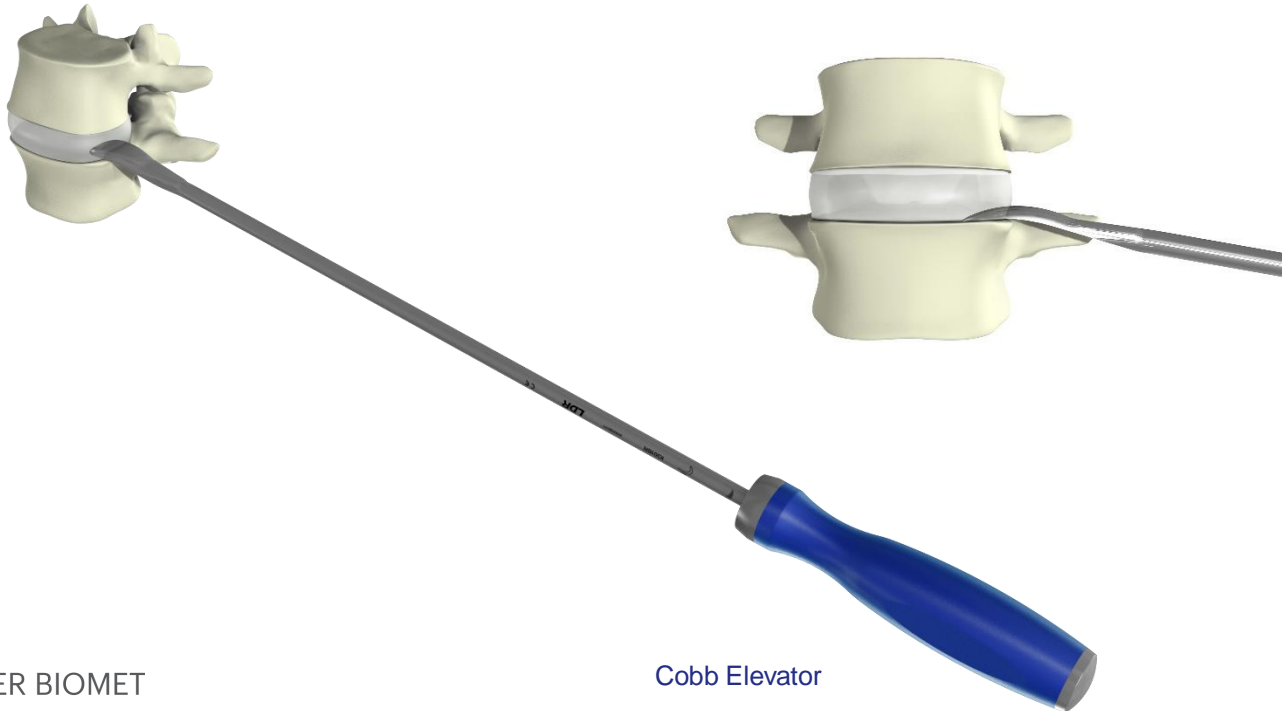

Note: It is not necessary to remove all the annular disc tissue antero-posteriorly. It is sufficient to remove the space corresponding to the cage. Maintaining the annular layers and the anterior ligament optimizes cage stability and facilitates arthrodesis.

Avenue® L

Discectomy & Endplate Preparation

- Fully insert the Paddle Distractors, which are provided in incremental heights, and gradually distract the disc space. The final disc height achieved should be consistent with the disc heights of the adjacent levels.

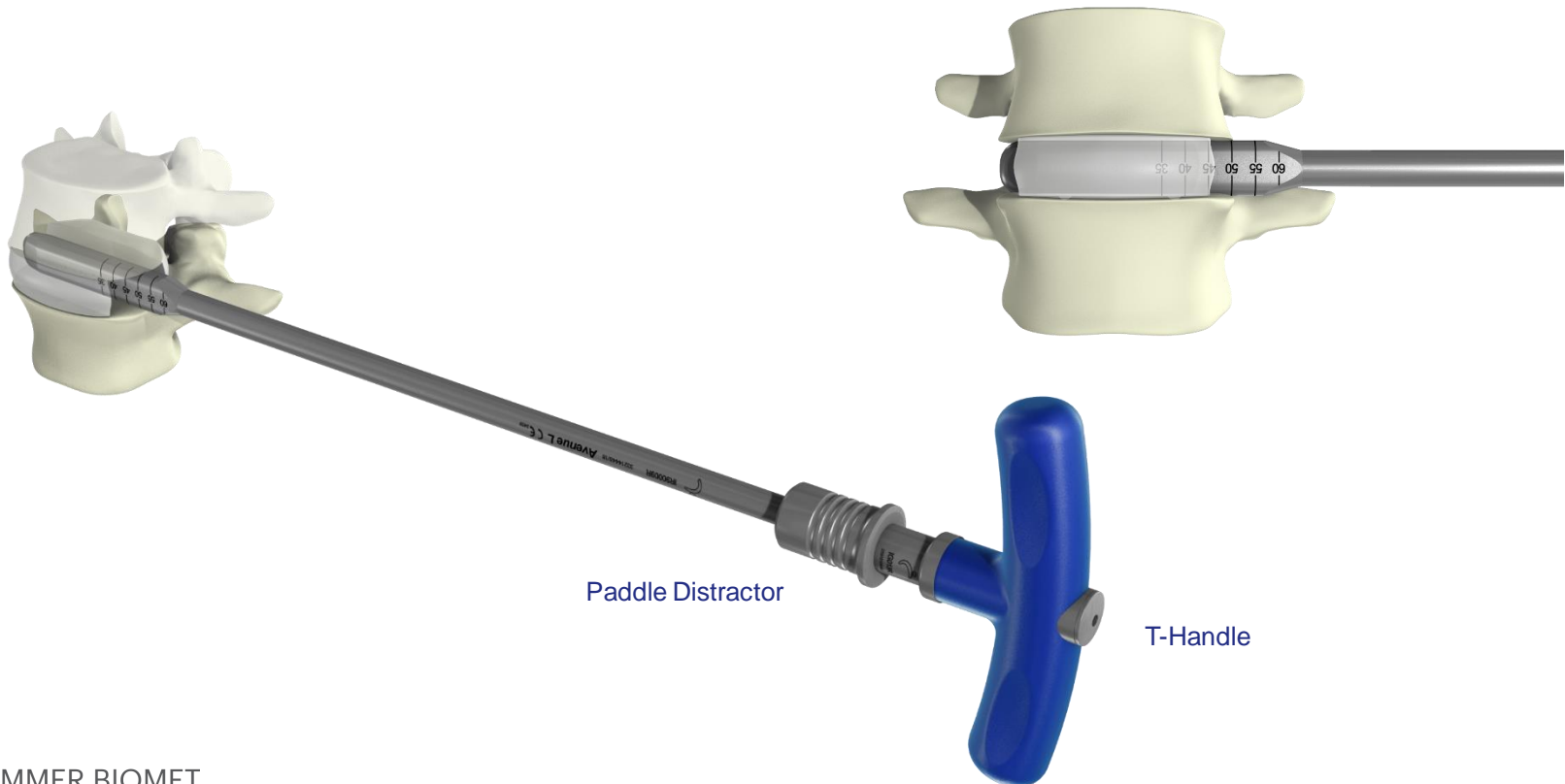

Avenue[®] L

Discectomy & Endplate Preparation

- Complete the discectomy and end plate preparation using preferred instruments.

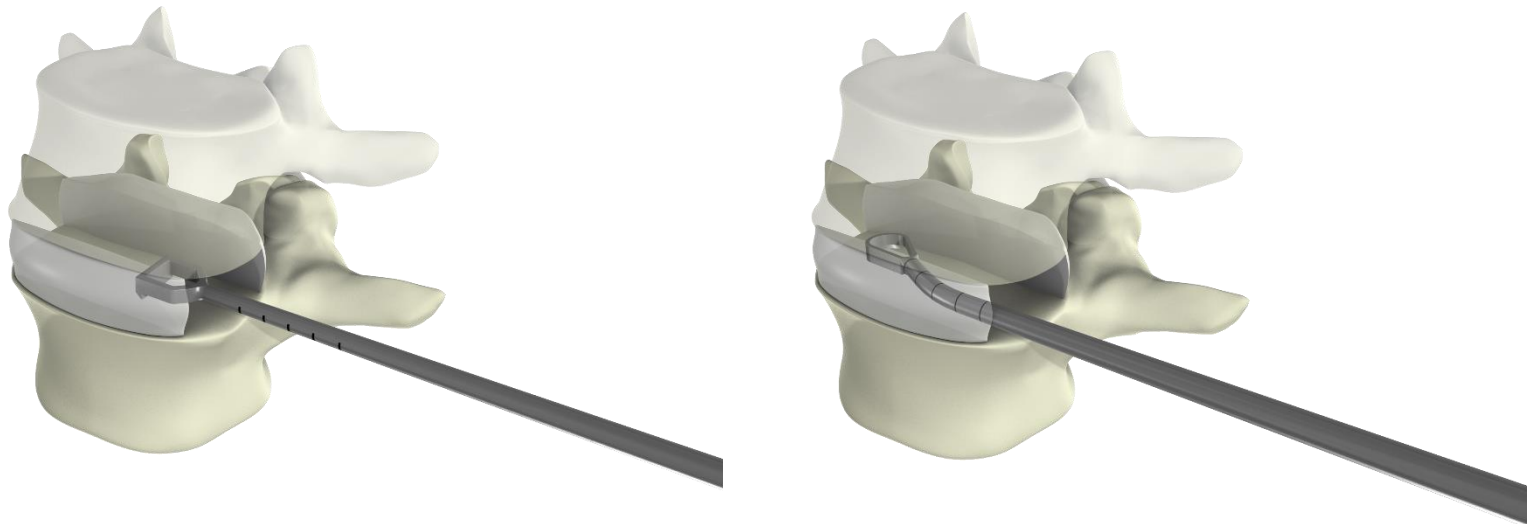

CAUTION: Endplate preparation should result in vascularization between the endplate and bone graft without weakening the cortical layer.

Avenue® L

Implant Trial Selection

- Proper implant selection is made using the Implant Trials. They are sized by length, width, height and lordosis in order to accommodate variation in patient anatomy. An implant sizing table is also available.

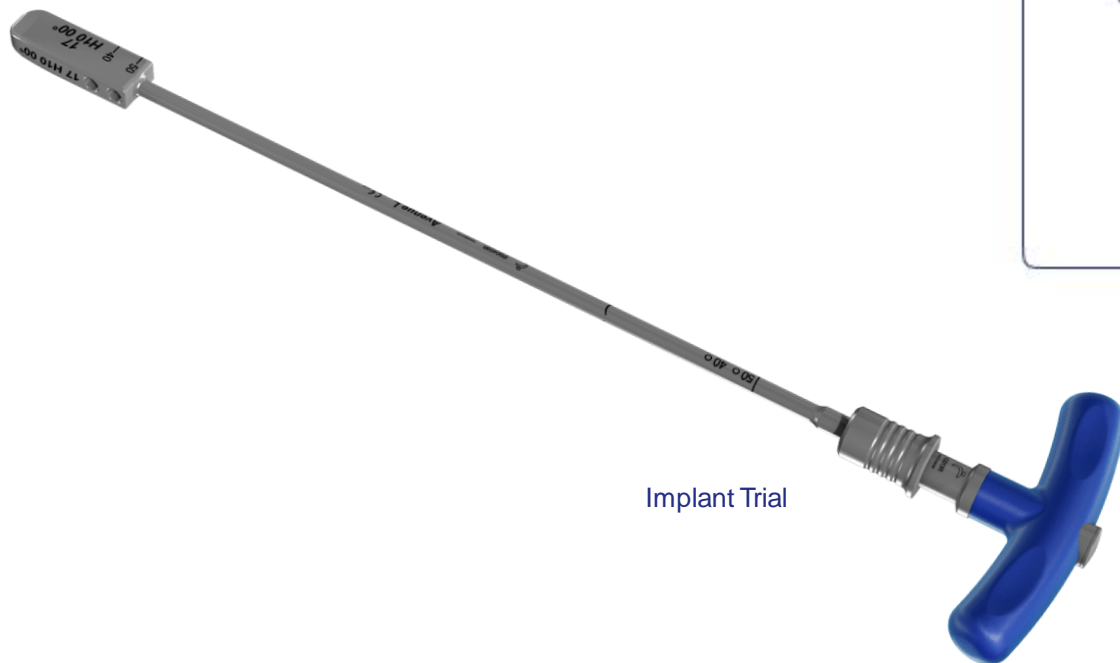
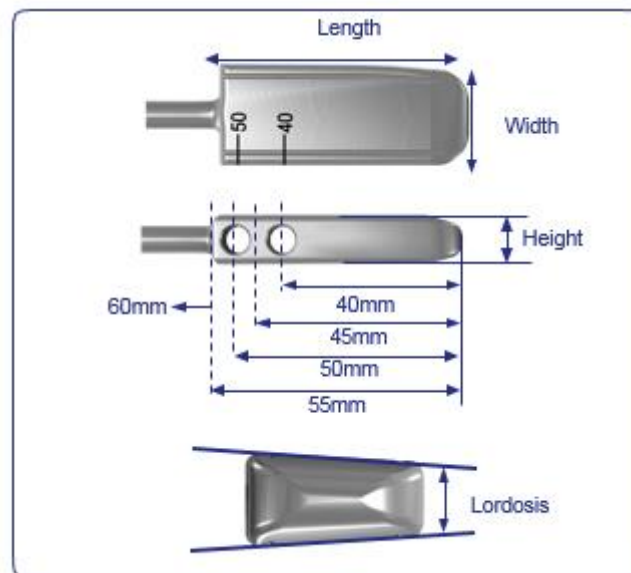

Implant Trial

T-Handle

Implant Trial Selection

- Insert the appropriate Implant Trial in the intervertebral space using the Slotted Mallet.
- Confirm position under fluoroscopy:
- Lateral image: Antero-posterior positioning and position in rotation.
- A/P image: Centering, lateral coverage and position in rotation.
- Once the proper size is determined, the Implant Trial is removed from the intervertebral space, and the corresponding cage can be implanted.

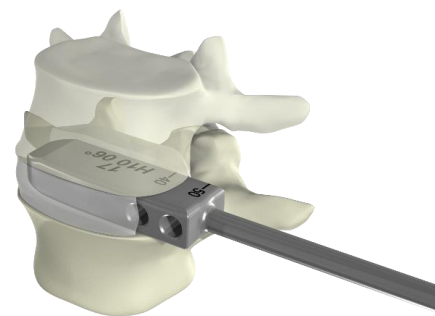

Note: During fluoroscopy, the T-handle can be removed for better visualization.

Note: The through holes in the Implant Trial are used to determine the appropriate implant length.



Slotted Mallet

Note: Implant Trial can be removed with the Slotted Mallet by guiding it along the trial shaft.

Implant Trial Selection

- Choosing the correct Implant Trial is crucial. The antero-posterior and lateral coverage of the Implant Trial on the vertebral endplate must be optimal in order to provide the best possible position and stability of the cage.
- In the A/P view, the Implant Trial must sit on the peripheral ring of the dense cortical bone. The Implant Trial (and resulting cage position) can protrude contralaterally per surgeon preference.
- The lordosis as well as the anterior and posterior heights must be chosen to obtain a height similar to adjacent discs, as well as the correct sagittal balance for the patient.

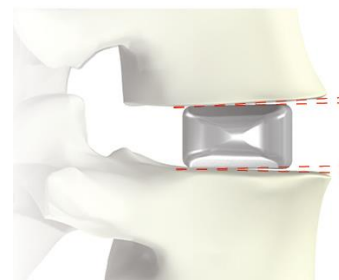
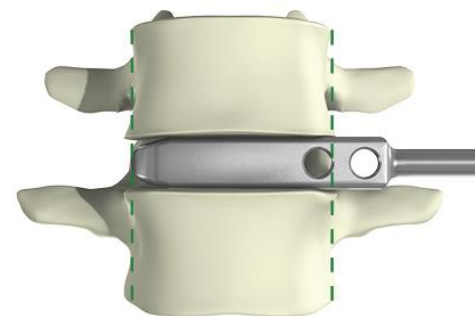

In this example, a 0° Implant Trial does not provide proper vertebral plate contact.

**INADEQUATE
ANTERIOR FIT**

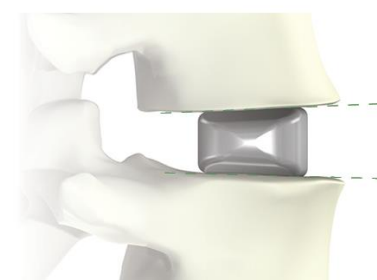

In this example, the 0° Implant Trial has been replaced by a 6° trial:
PROPER ANTERIOR FIT

In Line Slap Hammer - Optional

- Insert the 1/4" square shaft connection of the instrument into the distal collet of the Slap Hammer.
- Insert the 1/4" square shaft connection of the instrument into the distal collet of the Slap Hammer.



Avenue[®] L

In Line Slap Hammer - Optional

- Slide the In-Line Slap Hammer Handle in a controlled manner along the shaft to remove



- Slide the In-Line Slap Hammer Handle in a controlled manner along the shaft to remove the instrument.

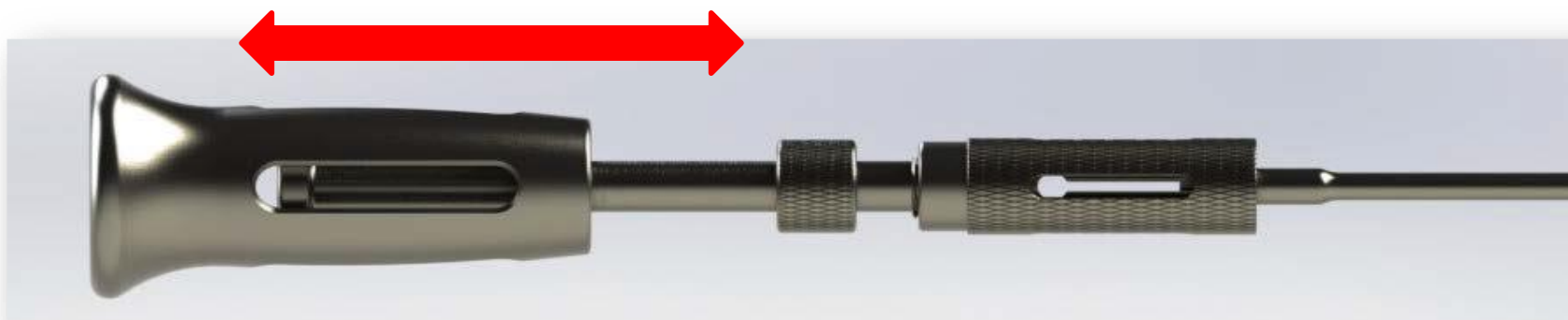

Avenue[®] L

In Line Slap Hammer - Optional

- In preparation for sterilization the slap hammer lock collet needs to be fully unlocked as shown below.



Avenue® L Implant Sizing Table

| VerteBRIDGE ® Plate | Plate Height (mm) | | | | |
|------------------------|-------------------|------|------|------|------|
| | H08 | H10 | H12 | H14 | H16 |
| Short (IR6001T) | 12.0 | 11.5 | 10.5 | 9.5 | 8.5 |
| Medium (IR6002T) | 15.5 | 14.9 | 13.9 | 12.9 | 11.9 |
| Long (IR6003T) | 19.2 | 18.7 | 17.7 | 16.7 | 15.7 |

| Reference Number & Graft Volume (cc) | | | | | | | | | | | |
|--------------------------------------|----|------------------|------------------|------------------|------------------|------------------|------------------|------------------|------------------|------------------|------------------|
| 0° Lordosis | | | | | | | 6° Lordosis | | | | |
| L | W | H08 | H10 | H12 | H14 | H16 | H08 | H10 | H12 | H14 | H16 |
| 40 | 17 | IR6208P (1.7) | IR6210P (2.0) | IR6212P (2.3) | IR6214P (2.7) | IR6216P (3.1) | IR6228P (1.6) | IR6230P (1.9) | IR6232P (2.3) | IR6234P (2.7) | IR6236P (3.1) |
| | 22 | IR6808P (2.4) | IR6810P (2.8) | IR6812P (3.4) | IR6814P (3.9) | IR6816P (4.5) | IR6828P (2.3) | IR6830P (2.6) | IR6832P (3.2) | IR6834P (3.8) | IR6836P (4.3) |
| 45 | 17 | IR6308P (2.0) | IR6310P (2.3) | IR6312P (2.8) | IR6314P (3.2) | IR6316P (3.7) | IR6328P (1.9) | IR6330P (2.2) | IR6332P (2.7) | IR6334P (3.2) | IR6336P (3.6) |
| | 22 | IR6908P (2.9) | IR6910P (3.4) | IR6912P (4.1) | IR6914P (4.8) | IR6916P (5.4) | IR6928P (2.8) | IR6930P (3.2) | IR6932P (3.9) | IR6934P (4.5) | IR6936P (5.2) |
| 50 | 17 | IR6408P (2.3) | IR6410P (2.6) | IR6412P (3.2) | IR6414P (3.6) | IR6416P (4.1) | IR6428P (2.1) | IR6430P (2.5) | IR6432P (3.0) | IR6434P (3.6) | IR6436P (4.1) |
| | 22 | IR7008P (3.4) | IR7010P (3.9) | IR7012P (4.7) | IR7014P (5.5) | IR7016P (6.3) | IR7028P (3.2) | IR7030P (3.7) | IR7032P (4.5) | IR7034P (5.3) | IR7036P (6.0) |
| 55 | 17 | IR6508P (2.5) | IR6510P (2.9) | IR6512P (3.4) | IR6514P (4.0) | IR6516P (4.5) | IR6528P (2.3) | IR6530P (2.8) | IR6532P (3.3) | IR6534P (3.9) | IR6536P (4.4) |
| | 22 | IR7108P (3.8) | IR7110P (4.4) | IR7112P (5.3) | IR7114P (6.1) | IR7116P (7.0) | IR7128P (3.6) | IR7130P (4.2) | IR7132P (5.0) | IR7134P (5.9) | IR7136P (6.7) |
| 60 | 17 | IR6608P (2.6) | IR6610P (3.0) | IR6612P (3.6) | IR6614P (4.2) | IR6616P (4.8) | IR6628P (2.5) | IR6630P (2.9) | IR6632P (3.5) | IR6634P (4.1) | IR6636P (4.7) |
| | 22 | IR7208P (4.2) | IR7210P (4.8) | IR7212P (5.8) | IR7214P (6.7) | IR7216P (7.7) | IR7228P (4.0) | IR7230P (4.6) | IR7232P (5.5) | IR7234P (6.4) | IR7236P (7.4) |

Avenue® L

Cage Holder Assembly and Cage Loading

- Introduce and screw the threaded rod into the Cage Holder.



1. Press the button on the Cage Holder Handle
2. Insert the Cage Holder into the Cage Holder Handle
3. Release the Button

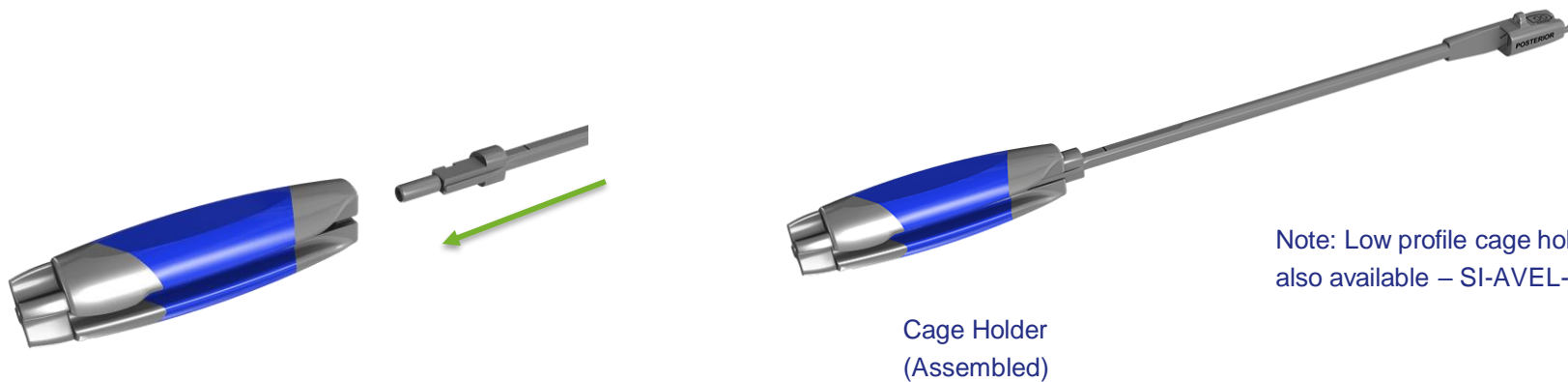

Note: Low profile cage holder also available – SI-AVEL-0001

Avenue[®] L

Implant Trial Selection

- Hook the Cage Holder in the groove located on the posterior side of the cage.

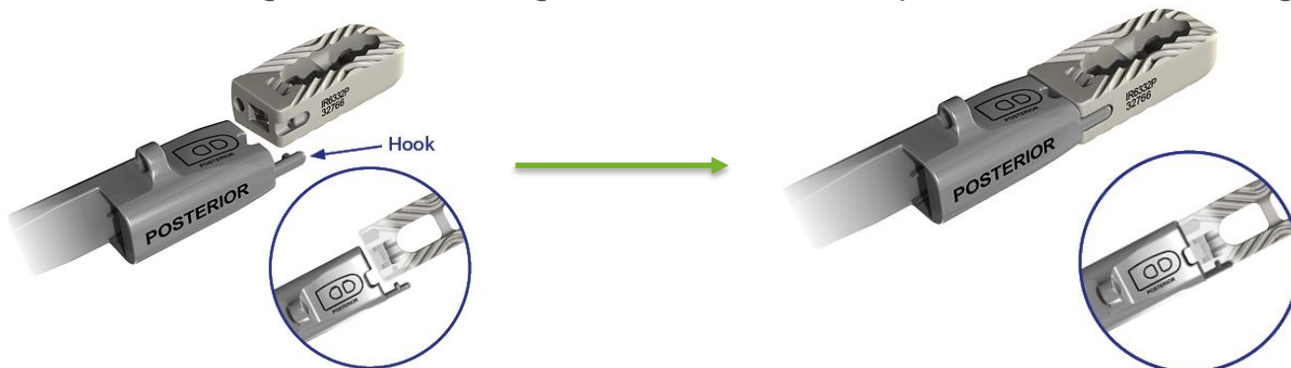

Note: Make sure that one of the grooves in the slotted knob aligns with the groove in the Cage Holder handle, so that the Impactor can be introduced.

- Screw the slotted knob finger tight to secure the cage onto the Cage Holder.
- CAUTION: Do not overtighten,, as this may strip the thread in the cage.

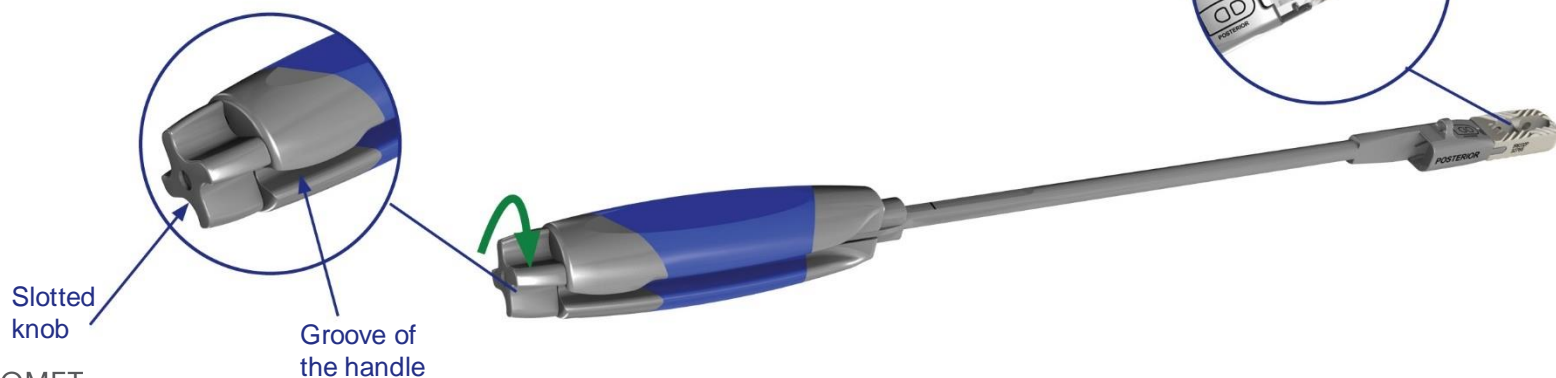

Avenue[®] L

Cage Preparation

- The graft chamber must be filled with bone graft. Place the cage in the Graft Support.



Graft Support

- Compact the bone graft into the chamber using the Graft Compactor.



Graft Compactor

Avenue[®] L

Cage Insertion

- Insert the cage in the intervertebral space by successive impactions on the Cage Holder, along the lateral axis. Note the orientation of the Cage Holder. Its posterior face has been labeled.
- The Adjustable Stop can be added to the Cage Holder to control the positioning of the cage during insertion.
- The position of the Adjustable Stop can be changed intraoperatively with the Adjustable Stop Screwdriver.

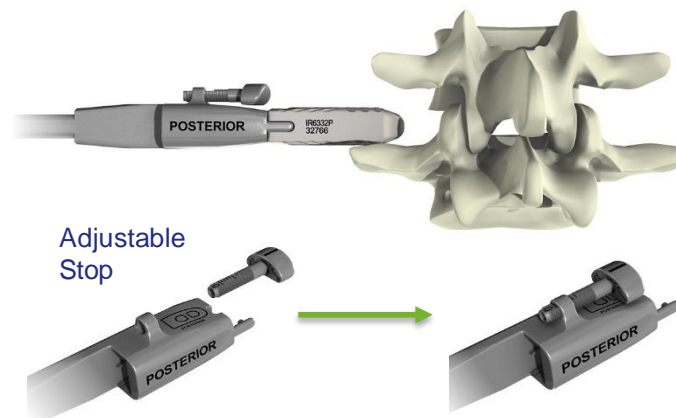

Note: The Adjustable Stop enables a variable positioning of the implant and maintains it during the insertion of the plating.

Note: With the stop set to 0 at the beginning of insertion, the proximal end of the cage will sit approximately 1.25 mm inside the disc space.

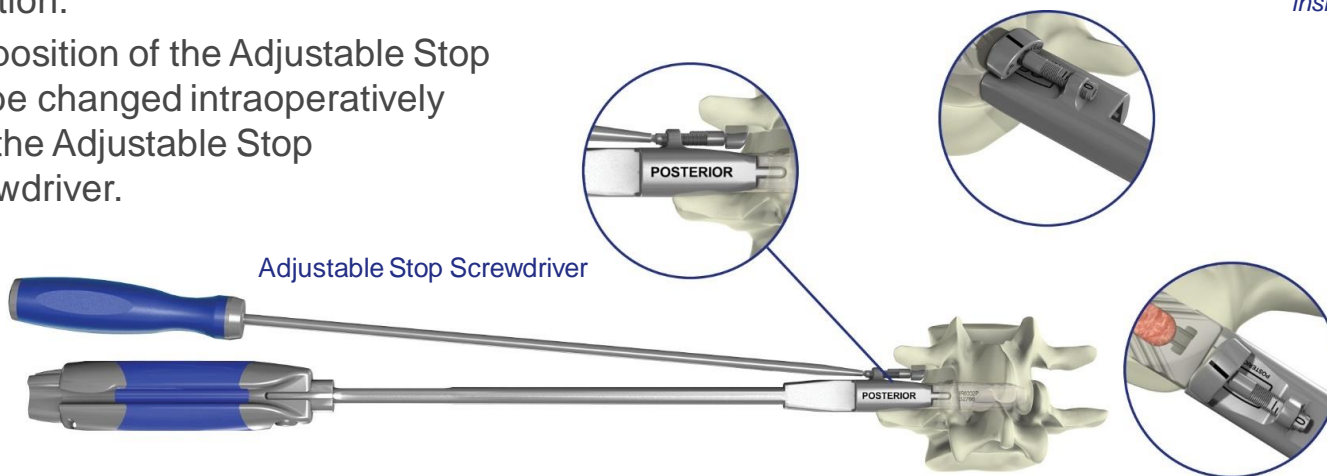

Avenue[®] L

Cage Insertion

- Confirm proper implant placement using fluoroscopy.



- Lateral View: The posterior face of the Cage Holder corresponds to the posterior face of the cage, allowing visualization of the A/P position of the cage.

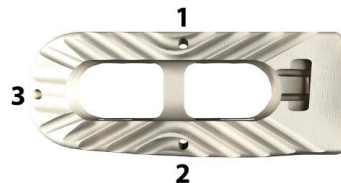
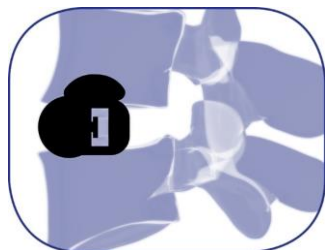

- A/P View: Central markers 1 and 2 indicate the implant center (their alignment proves the absence of rotation). Lateral marker 3 indicates the lateral edge of the cage. Under fluoroscopy, the edge of the cage inserter will indicate the proximal edge of the cage.

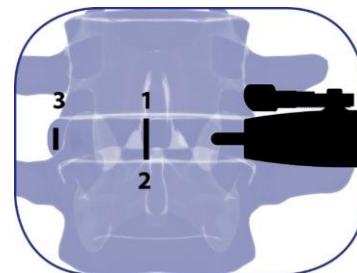
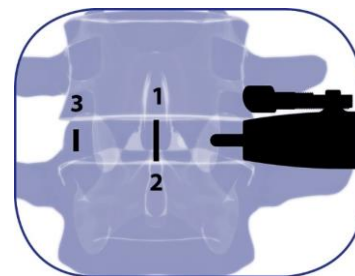

Note: The Modular Handle may be removed to facilitate fluoroscopic imaging.

Note: When placed at the proper depth, the proximal edge of the cage is inset approximately 1.25mm.

Note: If a wider cage is desired to protrude contralaterally to obtain full cortical support, the central markers will be offset from the midline in a true A/P view.

Cage Insertion

- The Cage Holder (IR 90019 R) and optional Adjustable Stop (IR 90020 R) are available in the standard instrument set so that the surgeon has access to either option.
- Note: Regardless of which Cage Holder is used, and whether or not the optional modular depth stop is assembled (Figure 4 and 5), it is essential to use fluoroscopy to confirm proper cage placement and that the cage position is maintained during deployment of the VerteBRIDGE® plating. Under the fluoroscopy, the distal edge of the Cage Holder will indicate the proximal edge of the cage. Images should be taken during and after cage and plate impactions.

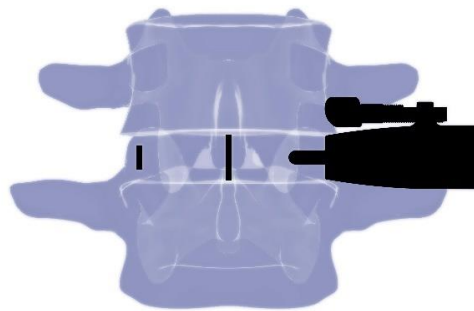

Figure 4. Fluoroscopic assessment with the existing Cage Holder (and Adjustable Stop)

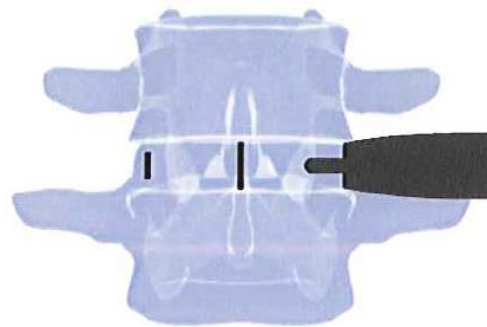
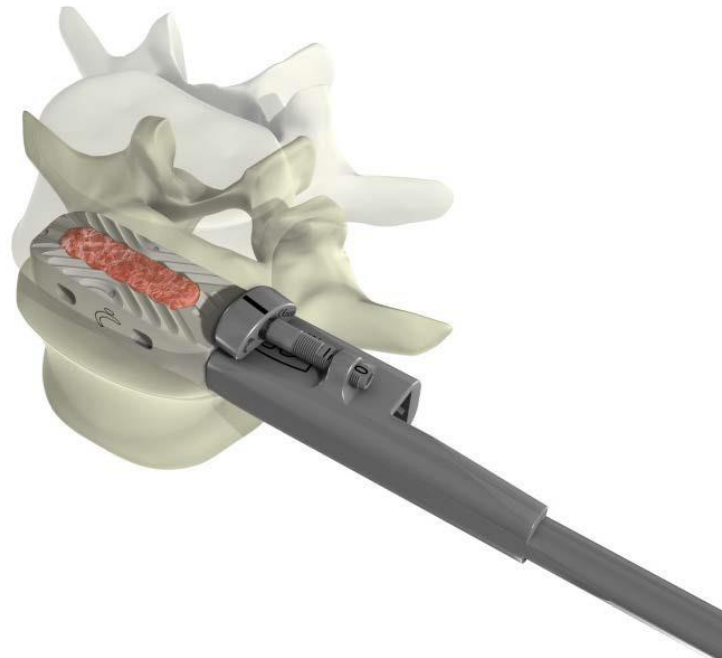

Figure 5. Fluoroscopic assessment with the new Low Profile Cage Holder

Avenue® L

Starter Awl

- The Avenue L Starter Awl is used after insertion of the Avenue® L cage and confirmation of the proper placement of the Avenue L Cage using fluoroscopy.



Avenue® L

Step 1: Starter Awl Selection & Assembly

- Select the starter awl depending on the anchoring VerteBRIDGE® plate size chosen:
 - Starter Awl S » VerteBRIDGE® Anchoring plate S
 - Starter Awl M » VerteBRIDGE® Anchoring plate M
 - Starter Awl L » VerteBRIDGE® Anchoring plate L

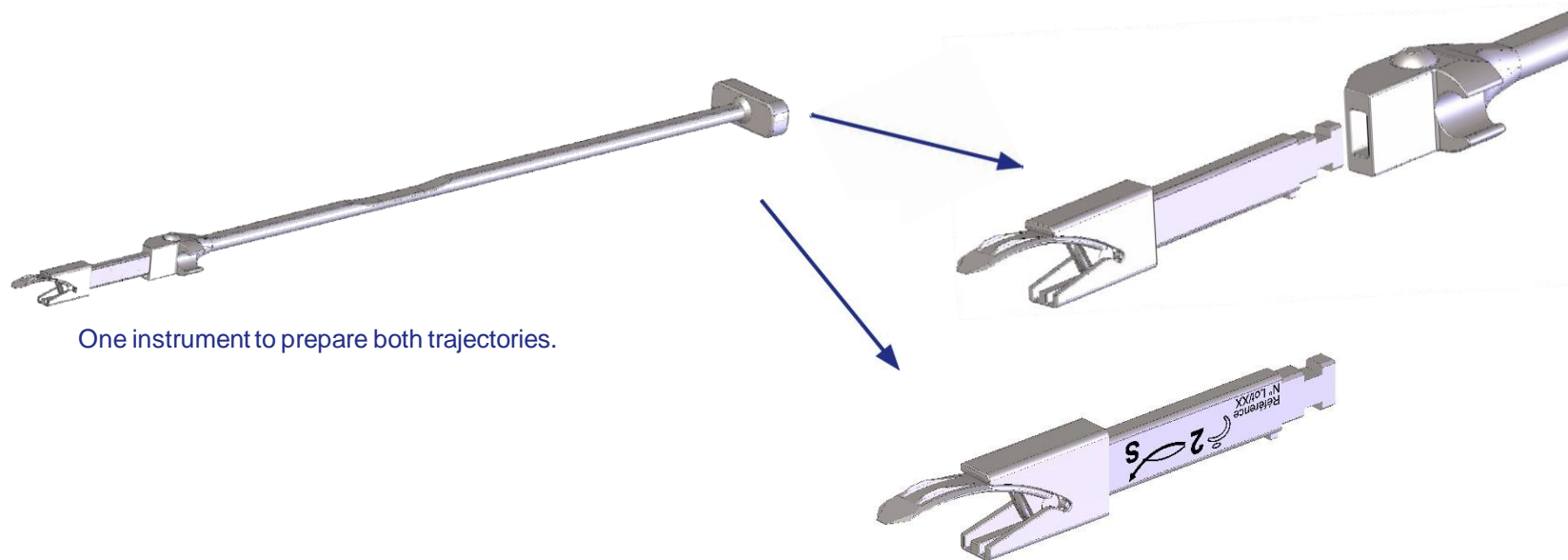

Avenue[®] L

Step 1: Starter Awl Selection & Assembly

- Engage the thinner part of the holder in the groove of the cage holder handle.

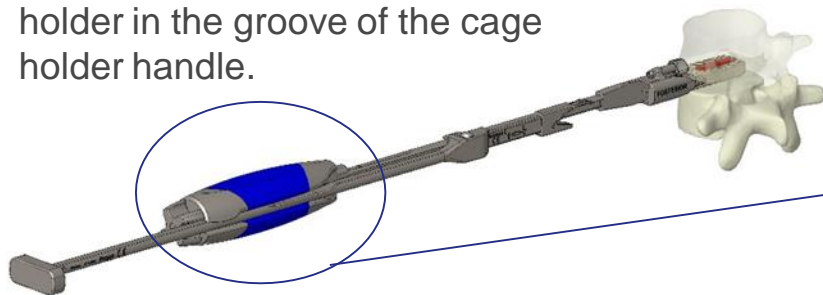

Area of thinner width.

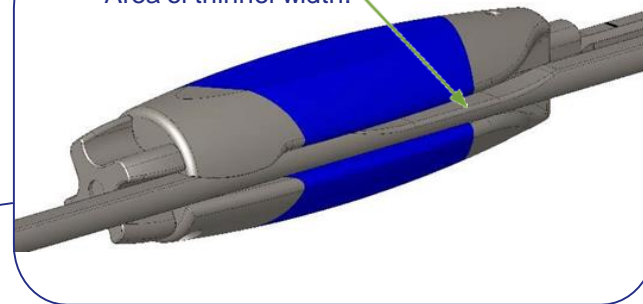

- When the instrument is placed blade make sure that the holder is fully engaged.
- There are markings (1 or 2) to note the trajectory of the Awl. These are the same as the numbering system on the PEEK cartridge of the Avenue L VerteBRIDGE[®] Plates



Avenue[®] L

Step 2: Create the 1st Groove

- Apply pressure to the Awl Holder until Awl is seated in the Implant Holder housing.
- Once seated apply thumb pressure to engage the Awl tip with the desired endplate
- Continue the insertion with a mallet until fully seated.
 - Laser etch lines on the awl holder and implant holder act as a secondary check to ensure awl is fully seated
- Remove the Starter Awl with a mallet or slotted slap- hammer
- Insert the 1st Avenue L Anchoring Plate following the Avenue L surgical technique.

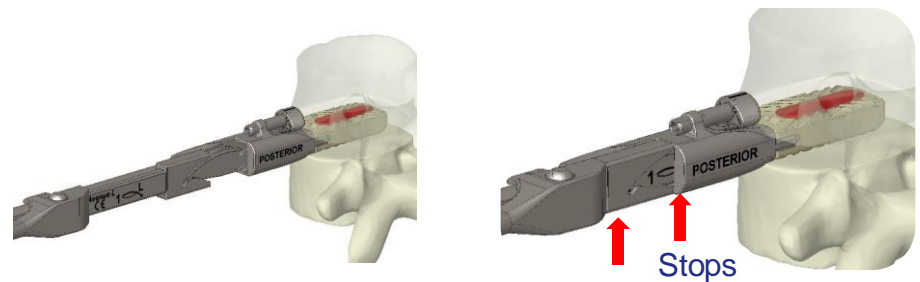
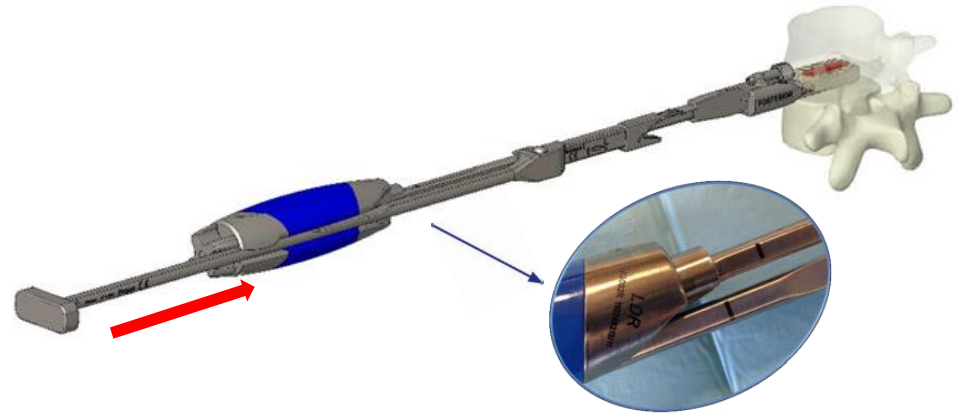

Avenue[®] L

Step 2: Create the 1st Groove

- Disassemble the Starter Awl and invert such that the 2 is showing.
- Perform the assembly on the cage holder as in Step 1
- Repeat the steps in Step 2 to create the second groove.
- After completing the second groove remove the Starter Awl.

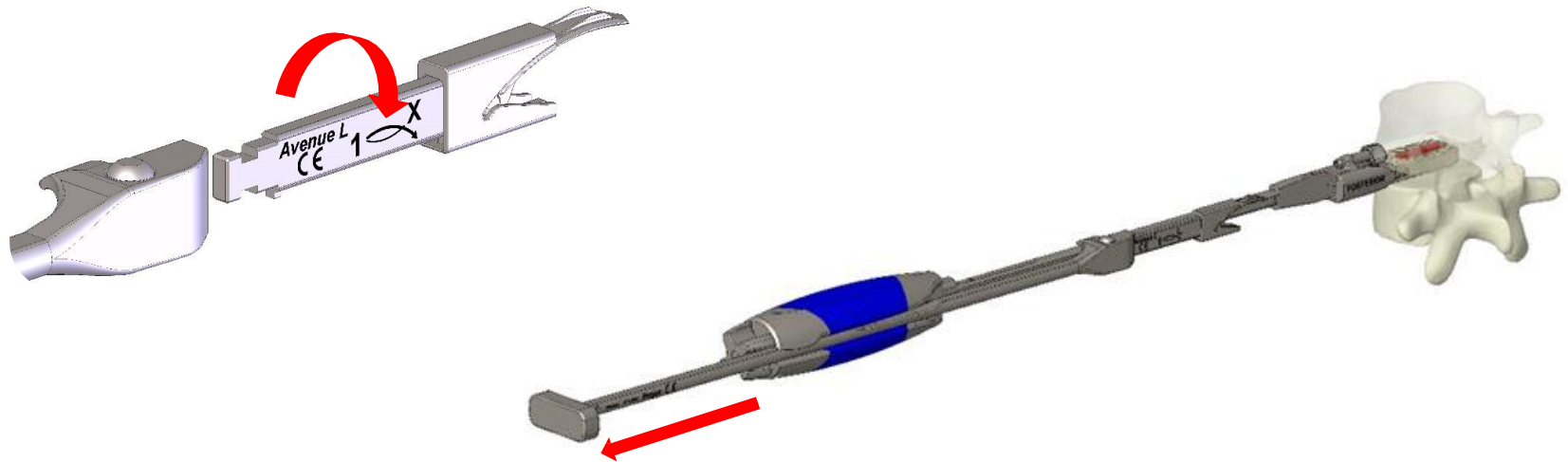

Avenue[®] L

Plate Insertion

- Once the position of the cage is determined, the plating can be inserted. The impaction of the plates is performed sequentially.
- Each plate comes pre-assembled on a radiolucent single-use Plate Holder.
- Insert the first Plate Holder on the Impactor up to the starting λ mark.
- Make sure the face marked ① is aligned with the λ mark on the Impactor.
- Insert the thinnest part of the Impactor in the groove of the Cage Holder handle. As the two instruments are joined, the mechanical stop guides the Impactor along the Cage Holder.

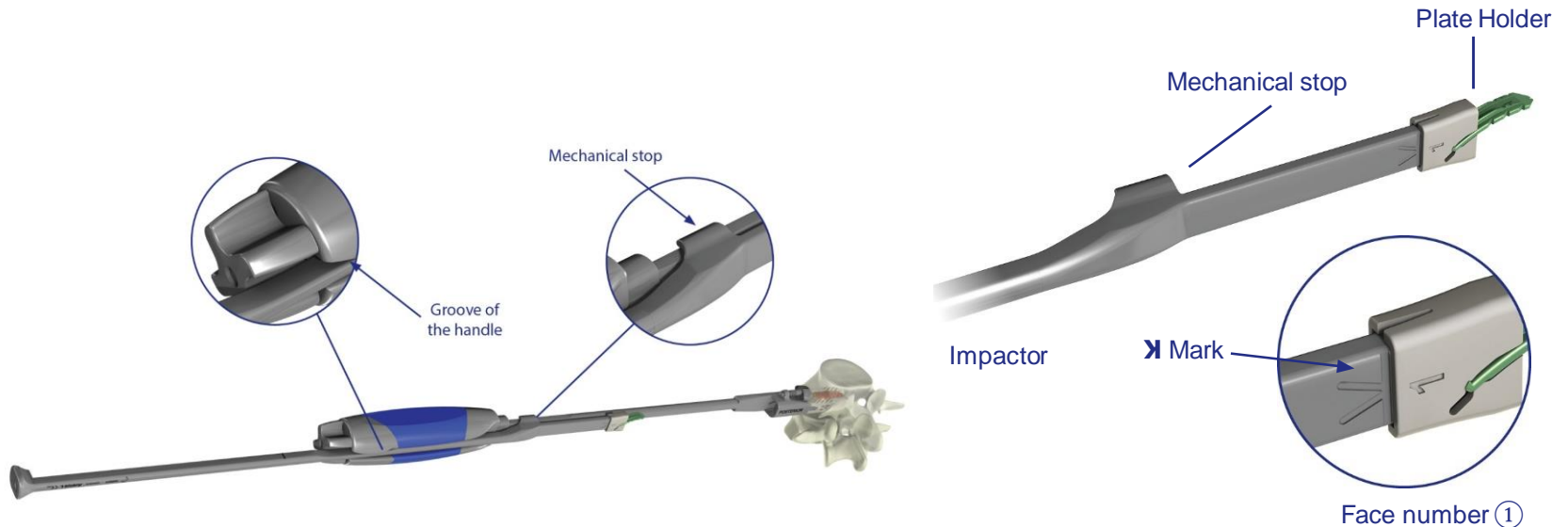

Avenue[®] L

Plate Insertion

- Using your thumb, press the Impactor until the plate bites into the vertebral body. Confirm plate trajectory with fluoroscopy. When trajectory is confirmed the plate may be fully inserted. Mallet the Impactor until it reaches the mechanical stop and the impaction marks are aligned.
- Check for proper placement of the first anchoring plate using fluoroscopy.

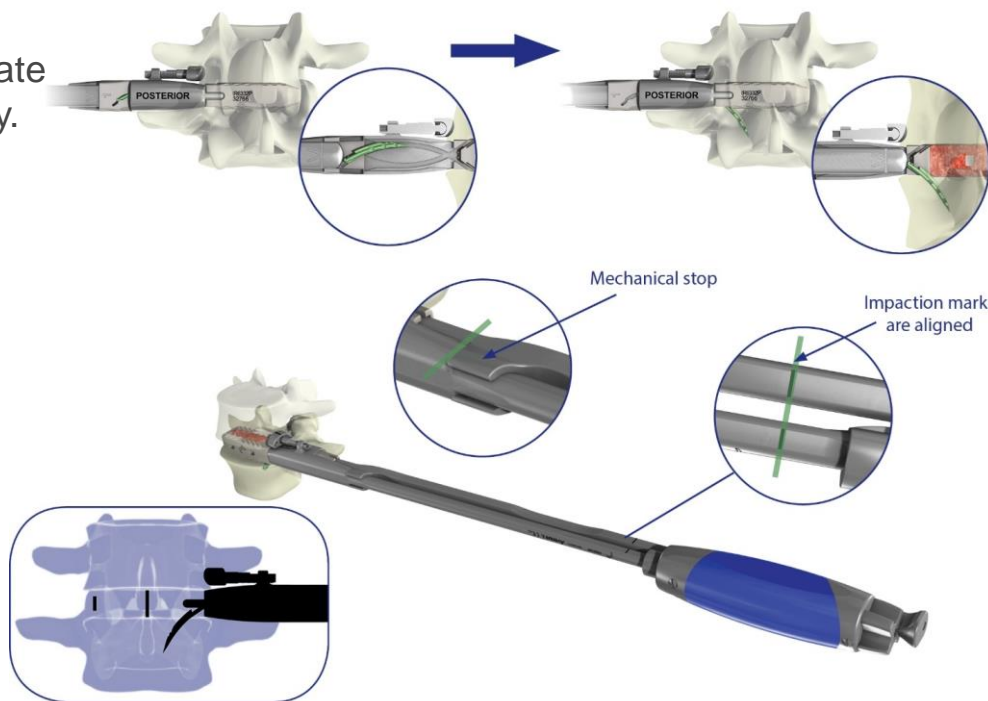

Note: The anchoring plate releases automatically from its holder. The empty plate holder is retained on the Impactor.

Note: When the Impactor is fully seated the impaction marks will be aligned.

Note: For 2-level implantation, “L” anchoring plates should not be used in the shared vertebra. Before inserting the plates, make sure that the vertebral bodies have sufficient height to avoid contact between the plates of the two implants.

Avenue® L

Plate Insertion

- Insert the second anchoring plate holder on the Impactor up to the starting mark.
- Make sure the face marked ② is aligned with the X mark on the Impactor. Insert the second anchoring plate by impacting on the Impactor until it reaches its mechanical stop and the impaction marks are aligned.

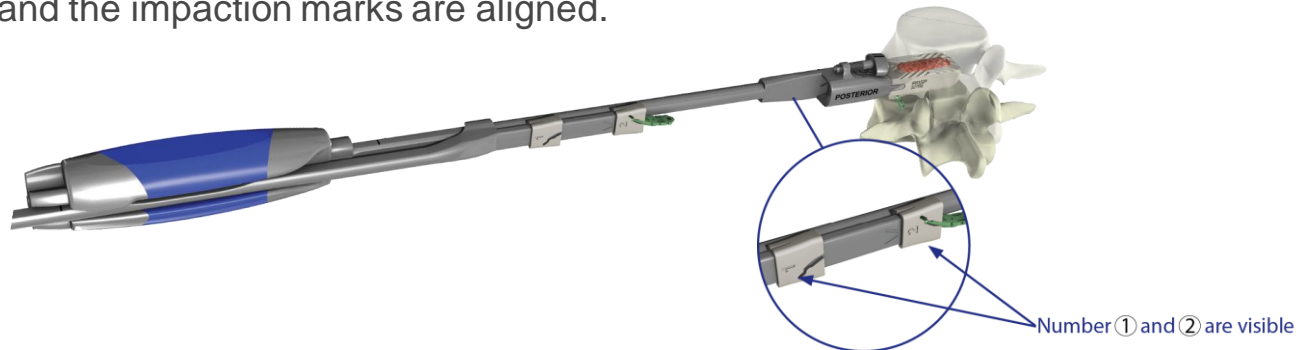

Note: The anchoring plate releases automatically from its Plate Holder. The empty Plate Holder is retained on the Impactor.

- Check for proper placement of the second anchoring plate using fluoroscopy.

CAUTION: At this step of the procedure, make sure that numbers ① and ② of the two Plate Holders are visible.

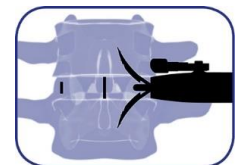
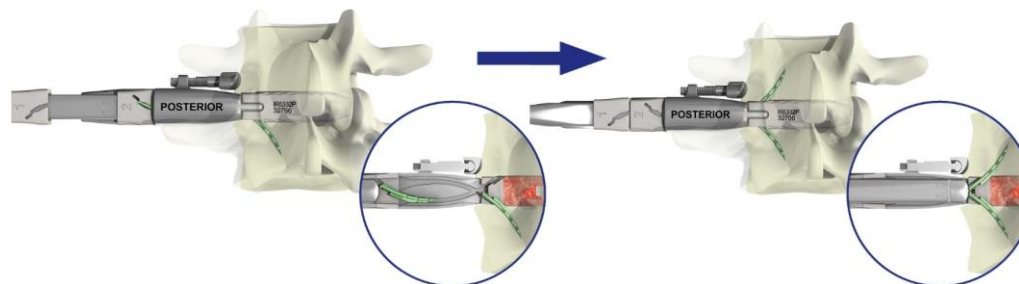

Avenue[®] L

Final verification and Cage Holder removal

- Unscrew the slotted knob to release the threaded shaft from the cage.
- Disengage the Cage Holder's hook from the cage groove with a slight posterior translation and remove it carefully from the intervertebral disc space.

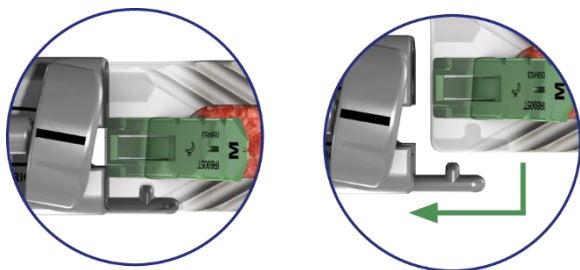

- A/P and lateral fluoroscopic verification of the plate placement confirms optimal position.

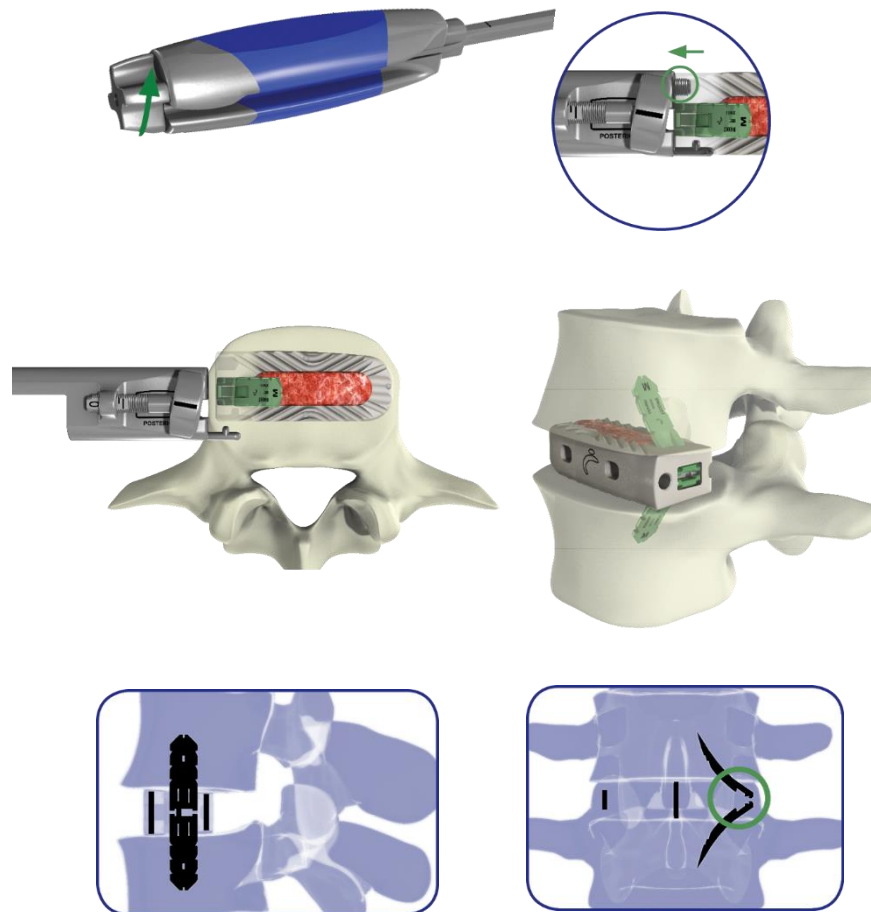

Avenue® L

Final Verification and Cage Holder Removal

- Dispose of the Plate Holders at the end of the procedure.

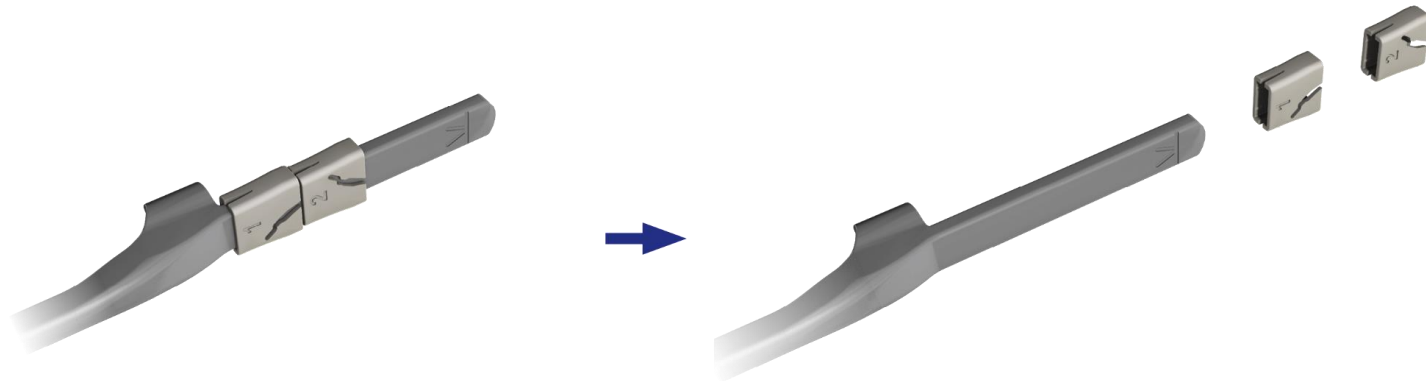

Supplemental Fixation

- VerteBRIDGE® plate trajectory must be reviewed via fluoroscopy prior to implanting supplemental posterior fixation. Steps should be taken during pedicle screw placement to confirm the screws will not contact the deployed VerteBRIDGE® plating.
- Make the initial path through the pedicle with the awl and/or pedicle probe.

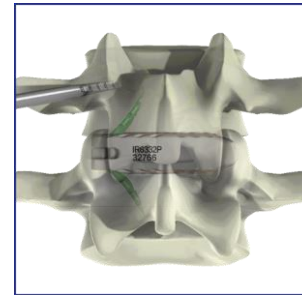
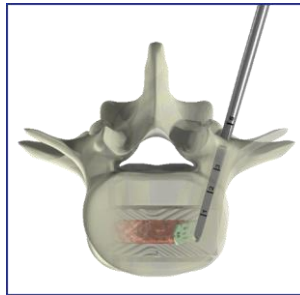
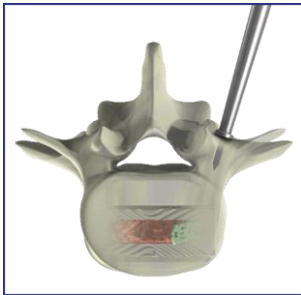

- Use the tap to create a path for the screw threads.

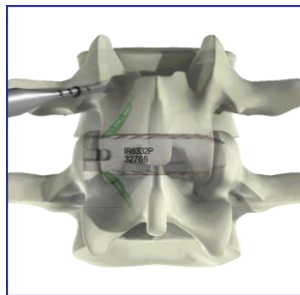
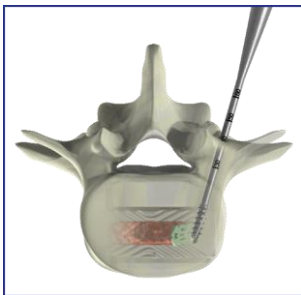

Avenue® L

Supplemental Fixation

- Use a pedicle probe to ensure that there is no interference between the screw trajectory and the VerteBRIDGE® plating.

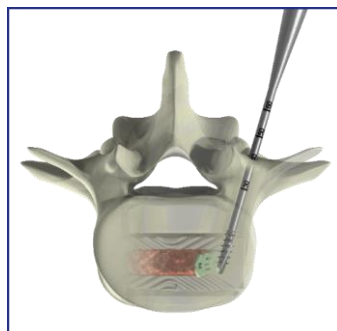

- If there is interference between the screw path and the VerteBRIDGE® plating during Steps 1-3, either create a new screw trajectory or select a shorter screw.

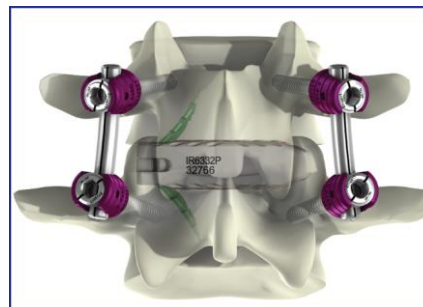
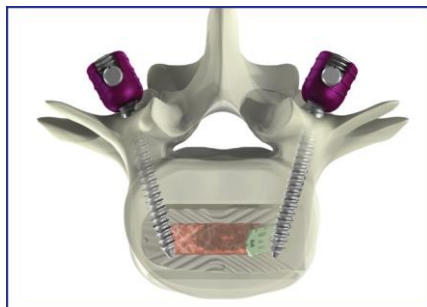

Avenue[®] L

Revision: VerteBRIDGE[®] Plate Removal

- A Revision System is provided in the event the plating must be removed

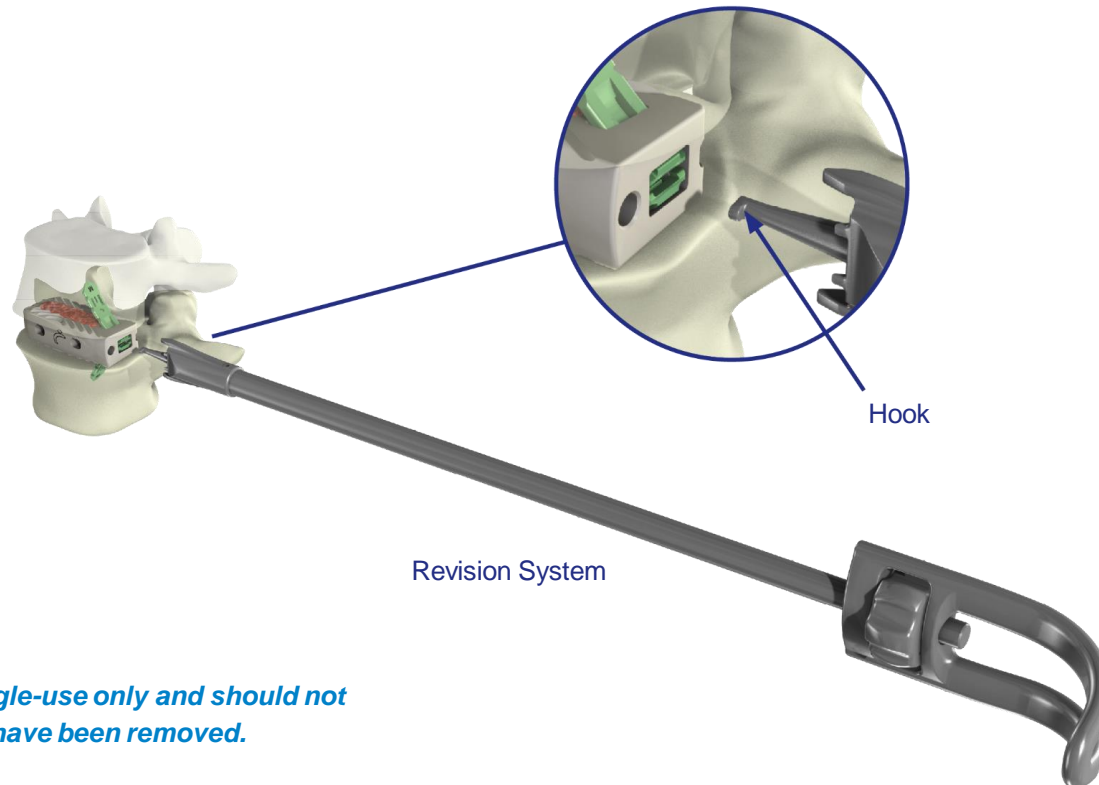

CAUTION: Plates are single-use only and should not be reinserted once they have been removed.

Revision: VerteBRIDGE® Plate Removal

1. Insert the Revision System hook parallel to and between the two plates.

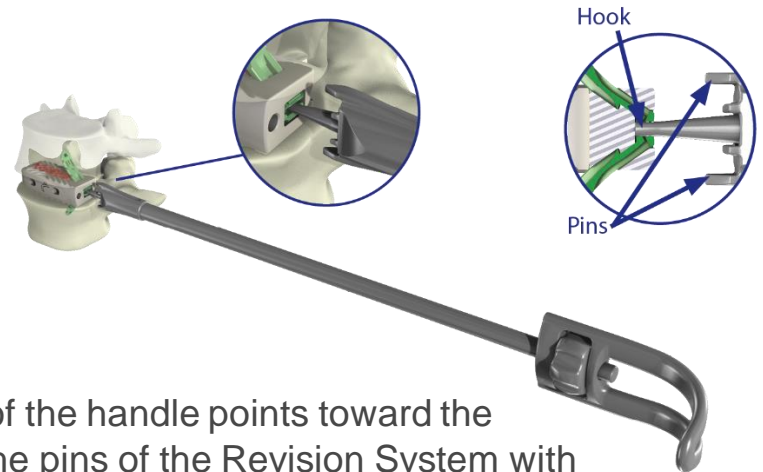

1. Rotate the instrument 90°, so that the curve of the handle points toward the anchoring plate to be removed. This aligns the pins of the Revision System with the corresponding implant slots (threaded hole and groove).
2. Screw the knob until the head of the revision system contacts the cage.

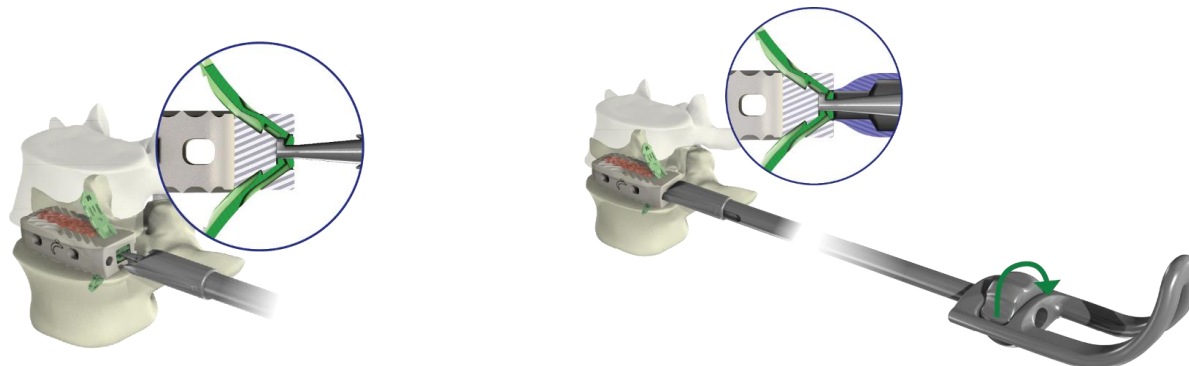

Revision: VerteBRIDGE® Plate Removal

- Once the plate is locked to the Revision System, slightly lever the instrument away from the plate that is being removed. This action unlocks the plate and in conjunction with the Slotted Mallet, eases plate removal.
- Repeat the previous steps in order to engage and extract the remaining anchoring plate.

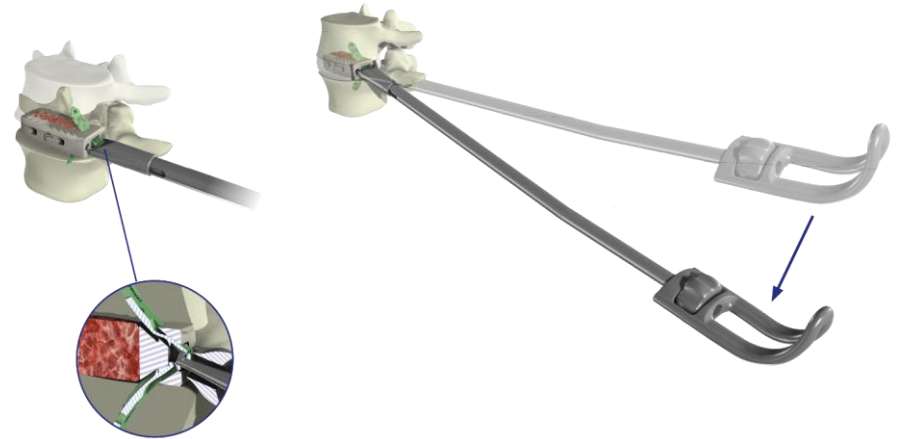

Revision - cage removal

- Reattach the Cage Holder to the implant and use the Slotted Mallet to progressively extract the implant.



Additional Instruments



- Lateral Disc Targeting Tool
 - Part # SI-AVEL-0022



- Disc Starters
 - 17mm x 6mm Part # SI-AVEL-0004
 - 22mm x 6mm Part # SI-AVEL-0005



- Cupped Cobb Elevators
 - 13mm Part # SI-AVEL-0015
 - 19mm Part # SI-AVEL-0016
 - 22mm Part # SI-AVEL-0017



- Straight Cobb Elevator
 - 22mm Part # SI-AVEL-018



- Angled Down Cobb Elevators
 - 19mm Part # SI-AVEL-0024



- Angled Up Cobb Elevators
 - 19mm Part # SI-AVEL-0025



- Disc Evacuators
 - 17mm x 6mm Part # SI-AVEL-0006
 - 17mm x 8mm Part # SI-AVEL-0007
 - 17mm x 10mm Part # SI-AVEL-0008
 - 17mm x 12mm Part # SI-AVEL-0009
 - 22mm x 6mm Part # SI-AVEL-0010
 - 22mm x 8mm Part # SI-AVEL-0011
 - 22mm x 10mm Part # SI-AVEL-0012
 - 22mm x 12mm Part # SI-AVEL-0013

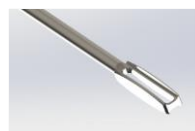

- Revolving Disc Cutter
 - 8mm Part # SI-AVEL-0019
 - 10mm Part # SI-AVEL-0020
 - 12mm Part # SI-AVEL-0021

Additional Instruments



- Apophyseal Ring Bridge
 - Part # SI-AVEL-0014

Note: Apophyseal Ring Bridges are intended to be used with low-profile cage holder only.



- Fluoro Modulator
 - Part # SI-AVEL-0023

Avenue® L

Device description

The Avenue® L implants are devices whose primary functions are to add a solid structure to a graft so as to enable the stabilization of intervertebral height, after discectomy, during the time of graft setting and achieve a maximum surface of fusion. Various sizes of these implants are available, so that adaptations can be made to take into account the pathology and individual patient. In addition, so as to favor bone growth, the Avenue® L lateral cage must be filled with bone graft.

The Avenue L implants are manufactured from (radiolucent) PEEK-OPTIMA® LT1 with surgical titanium alloy (Ti6Al4V) radiological position markers. The VerteBRIDGE® Anchoring Plates are manufactured from surgical titanium alloy (Ti6Al4V).

Instrumentation designed for implantation of the Avenue L Lateral Lumbar Cage is manufactured from biocompatible materials such as medical grade stainless steel.

Indications for use

The Avenue L Lateral Lumbar Cage system is indicated for intervertebral body fusion of the lumbar spine, from L2 to S1, in skeletally mature patients who have had six months of non-operative treatment. The device is intended for use at either one level or two contiguous levels for the treatment of degenerative disc disease (DDD) with up to Grade I spondylolisthesis. DDD is defined as back pain of discogenic origin with degeneration of the disc confirmed by history and radiographic studies. The device system is designed for use with or without integrated fixation and must be used in conjunction with posterior supplemental fixation (e.g. pedicle screws). The device system is intended to be used with autograft and/or allogenic bone graft composed of cancellous and/or corticocancellous bone graft to facilitate fusion.

Contraindications

- Cardiac problems.
- Abuse of medicine, drugs, tobacco or alcohol (which change the ossification power).
- Bony abnormalities preventing safe anchoring plate fixation.
- Material sensitivity, documented or suspected.
- Any mental or neuromuscular disorder which would create an unacceptable risk of fixation failure or complications in postoperative care.
- Bone stock compromised by disease, infection or prior implantation which cannot provide adequate support and or fixation to the implant.
- Obesity can produce loads on the spinal system which can lead to failure of the fixation of the device or to failure of the device itself.
- Recent infection, fever or hyper-leukocytosis.
- Open wounds.
- Bone absorption, osteopenia and/or osteoporosis.
- Patients having inadequate tissue coverage over the operative site.
- Pregnancy.
- Excessive local inflammation
- Other medical (for example: anesthetics risks) or surgical conditions which would preclude the potential benefit of spinal implant surgery such as the presence of tumors, congenital abnormalities, elevation of sedimentation rate unexplained by other diseases.
- Major spinal instabilities.
- Degenerative spondylolisthesis grade II or more.

Avenue® L

Warnings

Risks associated with general surgery, orthopedic surgery, and the use of general anesthesia should be explained to the patient prior to surgery. It is also recommended that the advantages and disadvantages of surgery, the implants, as well as alternative treatment methods be explained to the patient.

- Potential risks associated with the use of this system, which may require additional surgery, include device component failure (bending, loosening or fracture), loss of fixation, non-union, fracture of the vertebra, neurological injury, vascular or visceral injury, neurological complications, overdistraction, trauma to nerve root or dura, incorrect implant positioning, implant migration, pseudoarthrosis, disc height loss (impaction of implant into vertebral end plates), allergy or inflammation, general adverse effects related to surgical procedures (e.g. anesthesia, infection), subsidence, and expulsion.
- The device can break if it is subjected to increased loading associated with delayed union or non-union. If healing is delayed or does not occur, the implant could eventually break due to material fatigue. Factors such as the patient weight, activity level, and compliance to weight bearing or load bearing instructions, have an effect in the stresses to which the implant may be subjected, and may affect the longevity of the implant.
- Patients with previous spinal surgery at the level(s) to be treated may have different clinical outcomes compared to those without a previous surgery.
- Discard all damaged or mishandled implants.
- Under no circumstances may the implants be re-used. Although the device may appear intact on removal, internal modification due to the stress and strains placed on it or small defects may exist which may lead to fracture of the implant.
- Implants removed from a patient that contact bodily tissues or fluids should never be reused at risk of contamination of the patient.
- Mixing Metal: Some degree of corrosion occurs on all implanted metal and alloys. Contact of dissimilar metals (e.g. stainless steels and titanium), however, may accelerate this corrosion process. The presence of corrosion may accelerate fatigue fracture of implants and the amount of metal compounds released into the body system may also increase.
- Manufacturers employ different materials, manufacturing specifications and differing design parameters. Components of the Avenue L Interbody Fusion System should not be used in conjunction with components from any other manufacturer, except for the Zimmer Biomet Spine Timberline retractor.
- Any decision by a surgeon to remove the device should take into consideration such factors as the risk to the patient of the additional surgical procedure as well as the difficulty of removal.
- Implant removal should be followed by adequate postoperative management to avoid fracture.
- Before implanting the Avenue® L lateral cage, the vertebral plates must be carefully prepared, being careful not to weaken the cortical bone to avoid implant subsidence.
- The setting and possible repositioning of the Avenue® L lateral cage must be done with the cage holder attached to the cage.
- In order to ensure its stability in the intervertebral space, the Avenue® L implant must be used with a supplemental internal fixation system (plate and/or screws type).
- Do not attempt to reposition the implant after anchoring plates have been deployed into the vertebral endplates.
- Avenue L has not been evaluated for safety and compatibility in the MR environment. It has not been tested for heating, migration, or image artifact in the MR environment. The safety of Avenue L in the MR environment is unknown. Scanning a patient who has this implant may result in patient injury.

Precautions

- Being a technically demanding procedure presenting a risk of serious injury to the patient, the implantation of intersomatic systems should be performed only by experienced spine surgeons with specific training in the use of this system and who have knowledge of the present instructions for use.
- Based on fatigue testing results, when using the Avenue® L Implant System, the physician/surgeon should consider the levels of implantation, patient weight, patient activity level, other patient conditions, etc., which may impact on the performance of this system.
- Patients who smoke have been shown to have an increased incidence of non-unions. Such patients should be advised of this fact and warned of the potential consequences.

Avenue[®] L

Precautions (cont.)

- If the patient is involved in an occupation or activity which applies inordinate stress upon the implant (e.g., running, lifting of significant loads, or muscle strain), resultant forces can cause failure of the device.
- In some cases, progression of degenerative disease may also be so advanced at the time of implantation that they may substantially decrease the expected useful life to the implant. In such cases, orthopedic devices may be considered only as a delaying technique or to provide temporary relief.
- Before clinical use, the surgeon should thoroughly understand all aspects of the surgical procedure and limitations of the system. This device is recommended for use only by surgeons familiar with preoperative and surgical techniques, cautions and potential risks associated with spinal surgery. Knowledge of surgical techniques, selection and placement of implants, and pre and post-operative patient management are considerations essential to a successful surgical outcome.
- Patients should be instructed in detail about the limitations of the implants, including but not limited to the impact of excessive loading through patient weight or activity, and should be taught to govern their activities accordingly.
- Appropriate selection, placement and fixation of the spinal system components are critical factors which affect implant service life. Accordingly, strict adherence to the indications, contraindications, precautions, and warnings for this product is essential to potentially maximize service life.
- Care must be taken to protect the components from being marred, nicked or notched as a result of contact with metal or abrasive objects. Alterations will produce defects in surface finish and internal stresses which may become the focal point for eventual breakage of the implant.
- Inspection and trial assembly are recommended prior to surgery to determine if the instruments have been damaged during storage or prior procedures.
- After any surgery, it is necessary to check the proper position of the implants and to follow the evolution of the fusion using appropriate techniques
- For the anchoring plates, it is imperative to respect the following points:
 - During multi-level implantations, care should be taken in plate size selection to minimize the possibility of adjacent plate interference.
 - Ensure the cage does not protrude proximally outside the intervertebral disc space to be sure that the anchoring plates are properly positioned in the vertebral body.
 - Prior to implanting the posterior construct, use fluoroscopy to verify the trajectory of the anchoring plates to avoid impingement with pedicle screws.
 - If there is potential for the plates to contact pedicle screws, it may be necessary to change the trajectory of the screws.
- Sale of this product is restricted to physicians.

MR Safety Information

Non-clinical testing has demonstrated that the Interbody Cage Systems are MR-Conditional. Patients can be scanned safely immediately after implantation under the following conditions:

- Static magnetic field of 1.5 Tesla (1.5T) or 3.0-Tesla (3.0T).
- Maximum spatial gradient field of 3100 G/cm (31 T/m) for 1.5T Systems and 1500 G/cm (15T/m) for 3.0T systems
- Normal Operating Mode: Maximum whole-body specific absorption rate (SAR) of \leq 2.0 W/kg for 15 minutes of scanning at 1.5T.
 - 2.0 W/kg for 15 minutes of scanning at 3.0T.
- When other methods of supplemental fixation are used, also follow the MR conditional labeling for the additional components.
- Under the scan conditions defined above, the Avenue L Implant System is expected to produce a maximum temperature rise of less than 1°C after 15 minutes of continuous scanning.
- In non-clinical testing, the image artifact caused by the device extends approximately 1.0cm from the Avenue L Implant when imaged with a gradient echo pulse sequence in either a 1.5T or a 3.0T MRI system.

Avenue[®] L Retractor System



Avenue® L Retractor System

- Plug the probe to a suitable electrical source via DIN 42802 touch proof connectors.
- Insert carefully the probe in the smallest dilator tube groove. The detection ball (located at the end of the probe) will be exposed at the end of the dilator (see figure 2). **The ball probe should never stick out from the distal end of the dilator probe. Do not overstrain nor press too hard while inserting the probe.**
- Use the dilator holder to handle the dilators (see figure 3). Dilator holder can be connected to the table clamp to avoid surgeon hand exposure during X-rays
- Slide down carefully the smallest dilator containing the probe into the wound.
- Remove the probe from the dilator once nerve monitoring is completed and slide carefully the largest dilator on top of the smallest dilator. Nerve monitoring can be performed at this stage using the groove located in the dilator.
- Once the largest dilator is in position, it will provide the surgeon with the desired diameter where the retractor blades will fit tightly around it for the insertion of the device.
- Removing advice: First remove the probe, then the dilator. Dispose the probe after use.

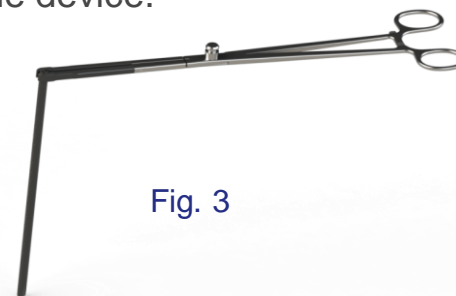

Retractor, Blades & Wrench

- The retractor, blades and wrench are reusable devices.
- Choose the blades size using the graduation on the dilators (blades length depending on the thickness of the patient, on the selected access for the surgery or on the surgeon's needs).
- Fix the 3 selected blades on the retractor body: they slide vertically either from the top or from beneath, until a click can be heard:
 - Place a right blade (R marked) on the right arm (R marked) (see figure 4)
 - Place a left blade (L marked) on the left arm (L marked)
 - Place a central blade (C marked) on the middle arm
- Before inserting the retractor in the wound, check that the retractor is well closed: blades shall make a closed circle (see figure 4).
If necessary, use the right and left screws to reduce the angle of the blades (refer to figure 6 for more details).
Then slide down the retractor body with its blades in the wound around the largest dilator (see figure 5).



Figure 4



Figure 5

Retractor, Blades & Wrench

- Spreading is obtained via 3 different movements (see figure 6)
 - a) Spreading of the lateral blades:** Squeezing the handle and screw the knob to maintain spreading as needed (see figure 7)
 - b) Tilting movement of the lateral blades:** to enlarge the well on the bottom, use the screws on the left and right arms: screwing opens angularly the blades, unscrewing closes the blades (see figure 8).
 - c) Lateral movement of the selected blades:** Screwing the big black knob will enlarge the opening, either the central blade will slide posterior or the 2 lateral blades will slide anterior, depending on where the retractor clamp is fixed to the table (see figure 9).

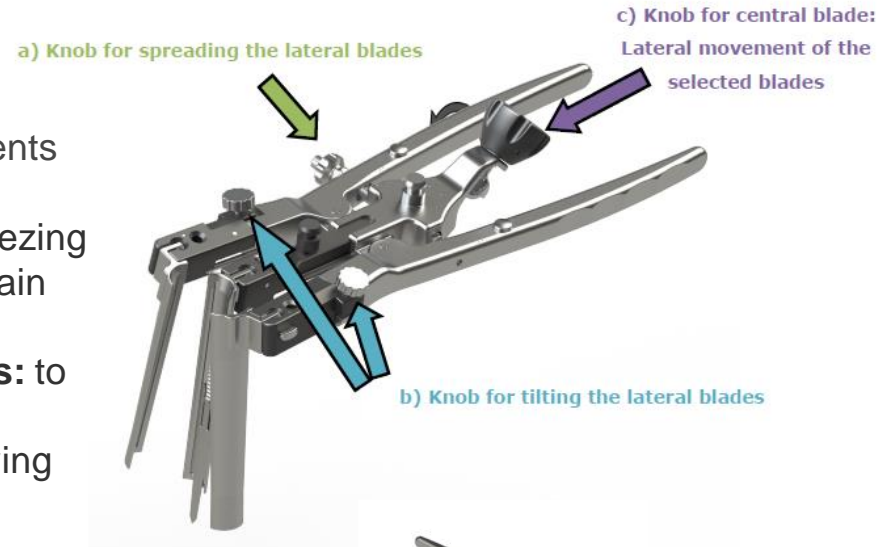

Retractor, Blades & Wrench

- Tip: The wrench can be used to screw and unscrew every knob of the retractor.
- Removing advice: To remove the blades from the retractor, use the push button on each arm of the retractor and pull the corresponding blade (see figure 10).

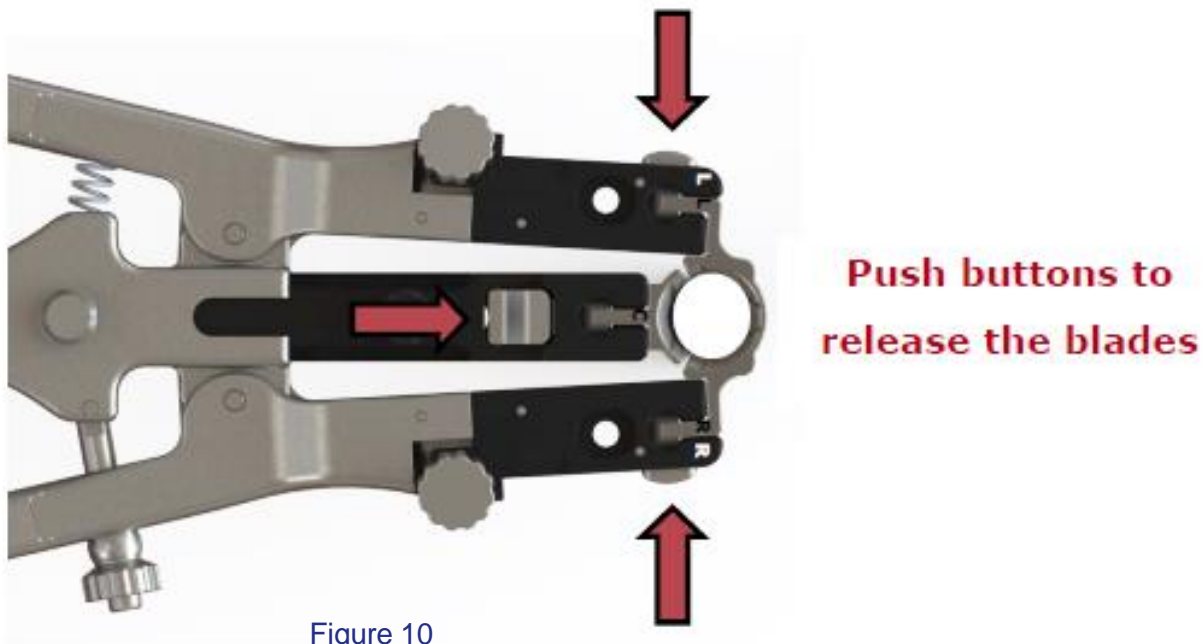

Avenue® L

Retractor, Blades & Wrench

- Below are instructions regarding the use of the Avenue Adjustable Table Clamp.
- Attach the Adjustable Table Clamp to the bed rail by turning the handle clockwise until the jaws have firmly grasped the rail. Typically the Adjustable Table Clamp is attached on the bed rail opposite the surgeon.
- Once the Adjustable Table Clamp is securely fastened to the bed rail insert the Avenue Flexible Arm and proceed starting on page 10 of the AVE ST4 Rev A.

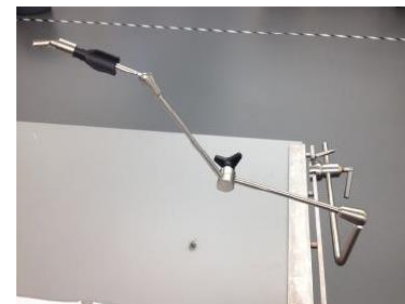

Avenue[®] L

Retractor, Blades & Wrench

- The table clamp is a reusable device. It's a flexible arm which is used to fasten the retractor to the surgery table
- To fix the flexible arm to the surgery table, refer to the specific Instruction For Use of the table clamp.
 - Use **knob 1** to fasten the table clamp base to the surgical table rail (see figure 11).
 - Use **knob 2** to set the height of the arm.
 - Use **knob 3** to lock the three articulations.
 - Use **knob 4** to fasten the retractor with the arm.

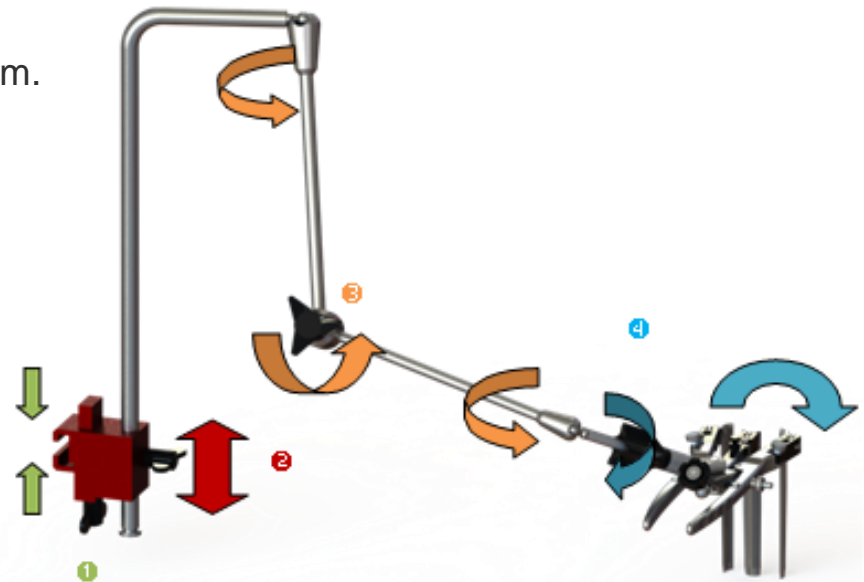

Note: Optional table clamp shown.

Retractor, Blades & Wrench

- Use the black connector to fix the table clamp to the retractor (see figure 12). To fix the retractor on the table clamp, depending on the surgeon choice, there are 2 different options:
 - **Central blade is mobile & lateral blades are fixed:** Use the steel lock to lock the retractor body and lateral blades. Only the central blade will slide forwards and backwards when screwing and unscrewing the black knob.
 - **Central blade is fixed and lateral blades are mobile:** Use the **black lock** to immobilize the central arm. Screwing and unscrewing the black knob will slide the lateral blades (and the retractor body) forwards or backwards.

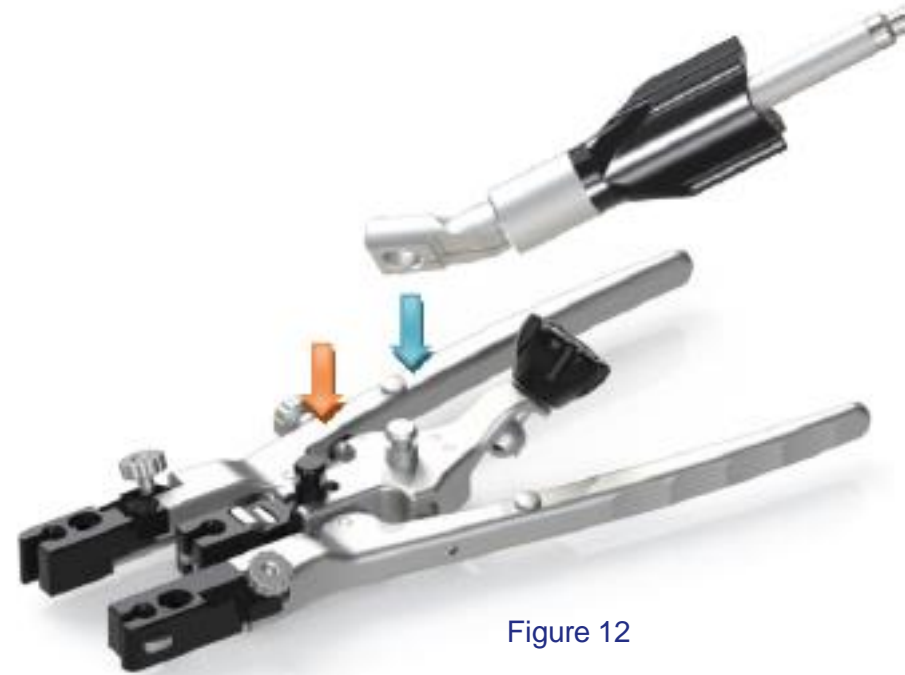

Figure 12

Disposable Light Mats & Extension Cords

- **The light mats are sterile single use products. Check the expiration date and the packaging before use.** Dispose after use. The extension cords are reusable.
- The light mat and its optic fiber cable are employed to light up the bottom of the wound.
 - Plug the extension cord to the light mat.
 - Plug the extension cord to a suitable light source, following the instructions for use of the light mats.
 - Slide carefully the mat through the dedicated slot inside the blade until the appropriate depth (see figure 13).
 - Removing advice: To remove the disposable light mat, slide carefully the light mat out of the blade. Dispose after use.



Figure 13

Light Cable & Light Holder

- The light cable and the light holder are reusable. The light cable helps to light up the wound.
- These lights are inserted into the light holder. The light holders are placed in their corresponding holes:
 - Spot 1: on the retractor body (see figure 14)
 - Spot 2: on the optional 4th blade support (see figure 15) (In that case, the 4th blade support uses the same holes as the light cables (spot 1): both plastic connectors of the 4th blade support are inserted in the retractor body as shown in figure 15.



Figure 14



Figure 15

Shim, broach and shim/broach holder

- Shim, broach and shim/broach holder are reusable products.
 - Clip the shim (or broach) lug in the shim/broach holder dedicated claw on the top end of the holder (see figure 16). The laser marking on the shim (or broach) provides you with the correct orientation.
 - Make sure the lug is well tightened by the holder claw (see figure 17) before locking the shim (or broach) by pushing the firing pin (with the thumb) (see figure 18).
 - Insert the shim (or broach) into the blade dedicated slot until the suitable depth (see figures 19 & 20).
 - Release the shim (or broach) by pushing the trigger (with the forefinger).



Figure 16



Figure 17



Figure 18

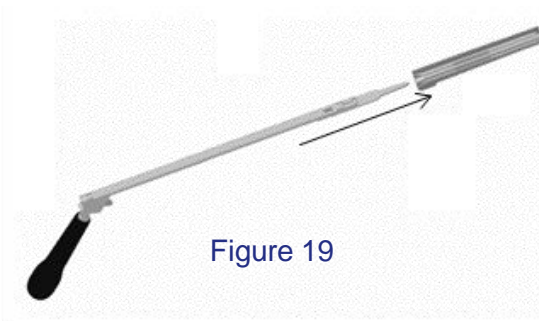

Figure 19



Figure 20

Shim, Broach & Shim/Broach Holder

- The blade extension is reusable.
 - Handling of the blade extension (see figure 21) is similar to the shim/broach procedure.
 - Make sure the lug is well tightened by the holder claw (see figure 17) before locking the blade extension by pushing the firing pin (with the thumb) (see figure 18).
 - Insert the blade extension into the blade dedicated slot until the suitable depth (see figure 22).



Figure 22



Figure 22

Optional 4th Blade & Support

- The 4th blade and its support are reusable.
 - Clip of the 4th blade support connectors to the retractor spots (see figure 23) (they are the same spots used to plug the light cables in chapter 1.3.7 Light cable and light holder).
 - Select the suitable 4th blade (depending on the required length and width). Insert the 4th blade in the dedicated groove inside the support. At this point the 4th blade is still mobile: it can be moved **up and down** (through the groove support) or **laterally** (support is sliding), even **angularly** (see figure 24).
 - Lock the height and the lateral position of the 4th blade screwing the knob with the wrench (see figure 25).



Figure 23

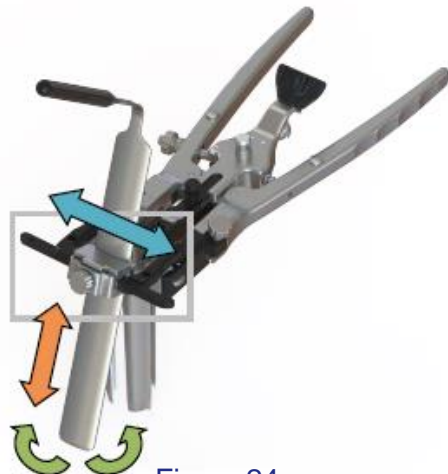

Figure 24



Figure 25

Cleaning, Sterilization & Maintenance

- Recommendations for the handling of these surgical instruments are as follows:
 - Do not let blood or tissue dry on the instrument
 - Rinse the instrument immediately after use and before decontamination.
 - As much as possible, manipulate instruments made from different metals separately.
 - Check the functionality and cleanliness of each instrument before use.
 - Time dwell between use and cleaning of the devices should be minimal.
 - Devices should be carried into wet wraps from the surgery room to the cleaning room.
 - Some devices should be disassembled prior to cleaning, some should be handled specifically prior to cleaning, as described below.
- 2.1.1. Disassembling of the retractor
 - Hold the tips away from each other screwing the lateral nut and turn the black knob until the central arm is totally out.
 - Both handles have to be removed from the retractor body. Push the left and right buttons to release both handles (see figure 27).

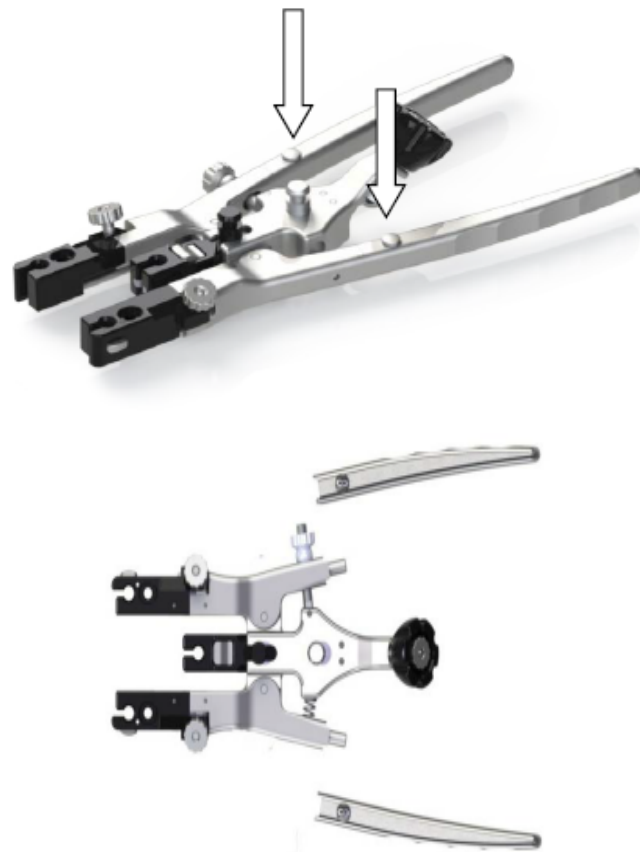

Figure 27

Shim/Broach Holder Disassembling

- Disassemble the shim/broach holder for cleaning: take off the pin (see figure 28), then pull the firing pin and hold up the rod (see figure 29).



Figure 28



Figure 29

- 2.1.3. 4th blade support special handling care
 - The support must be completely opened (maximum wingspan) to maximize the access for cleaning (see figure 30). Screw must be totally loosened.

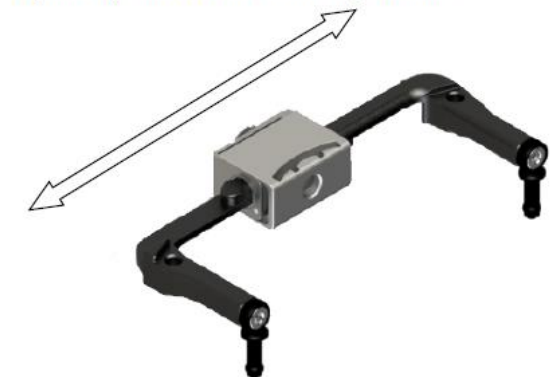

Figure 30

Avenue[®] L

Maintenance

- Use surgery lubricant before each use. Apply only where it is recommended in the following pictures (red circles).

WARNING: DO NOT lubricate any part which will be in contact with the patient.

- 2.5.1 Retractor

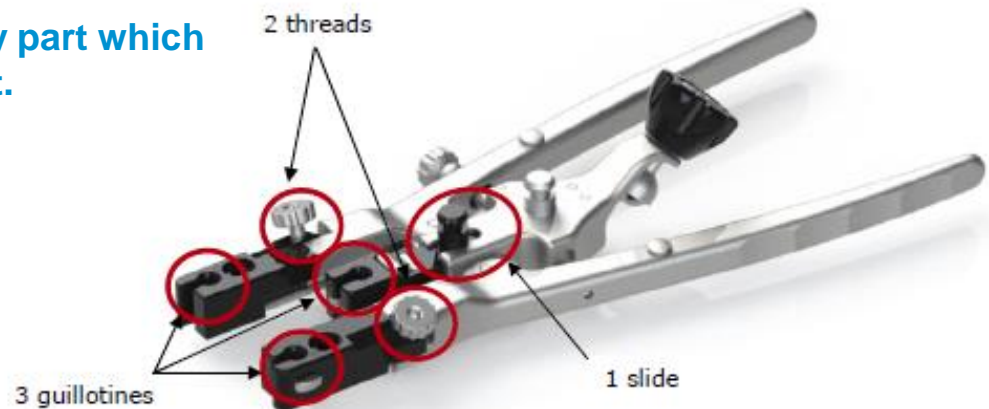

- 2.5.2. Table clamp connector



Avenue® L

Maintenance

- 2.5.3



- 2.5.4. Shim holder

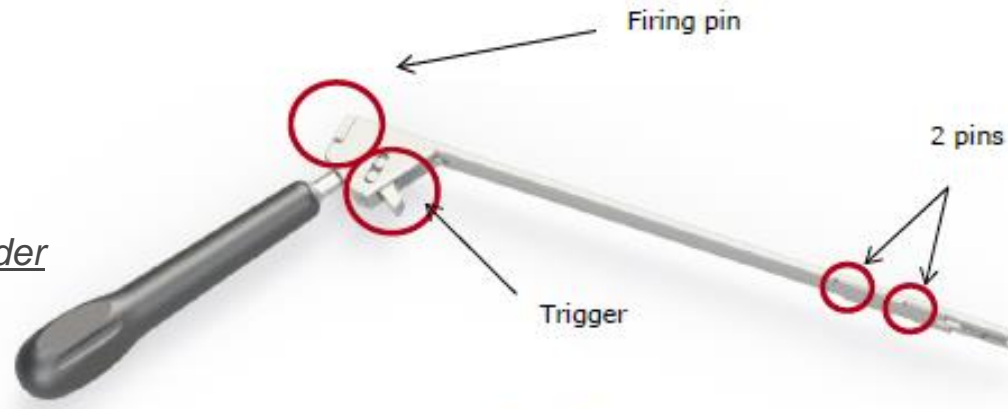



ZIMMER BIOMET

Your progress. Our promise.™

Disclaimer: This document is intended exclusively for physicians and is not intended for laypersons. Information on the products and procedures contained in this document is of a general nature and does not represent and does not constitute medical advice or recommendations. Because this information does not purport to constitute any diagnostic or therapeutic statement with regard to any individual medical case, each patient must be examined and advised individually, and this document does not replace the need for such examination and/or advice in whole or in part.

Caution: Federal (USA) law restricts this device to sale by or on the order of a physician. Rx Only. Please refer to the package inserts for important product information, including, but not limited to, indications, contraindications, warnings, precautions, adverse effects, and patient counseling information.

ldr.com

©2017 LDR, a division of Zimmer Biomet Spine, Inc. All rights reserved.

All content herein is protected by copyright, trademarks and other intellectual property rights owned by or licensed to LDR, a division of Zimmer Biomet Spine, Inc. or one of its affiliates unless otherwise indicated, and must not be redistributed, duplicated or disclosed, in whole or in part, without the express written consent of Zimmer Biomet Spine. This material is intended for health care professionals and the Zimmer Biomet Spine sales force. Distribution to any other recipient is prohibited.