

**YOUR TRUSTED
SOLUTION.
BECAUSE
POSTERIOR
CERVICAL
SHOULD
BE EASIER.**

Infinity™

Occipitocervical-Upper Thoracic System



Medtronic



YOU ASKED. WE ANSWERED. EFFICIENCY PLUS REFINEMENT.

Depend on the versatility and utility of Infinity™ OCT System to simplify even the most complex of procedures.

Combining a complete platform refresh of the core implants and instruments, with a full suite of enabling solutions, to bring **procedural efficiency** to all your posterior cervical fusions.

**Because Posterior Cervical
Should Be Easier.**

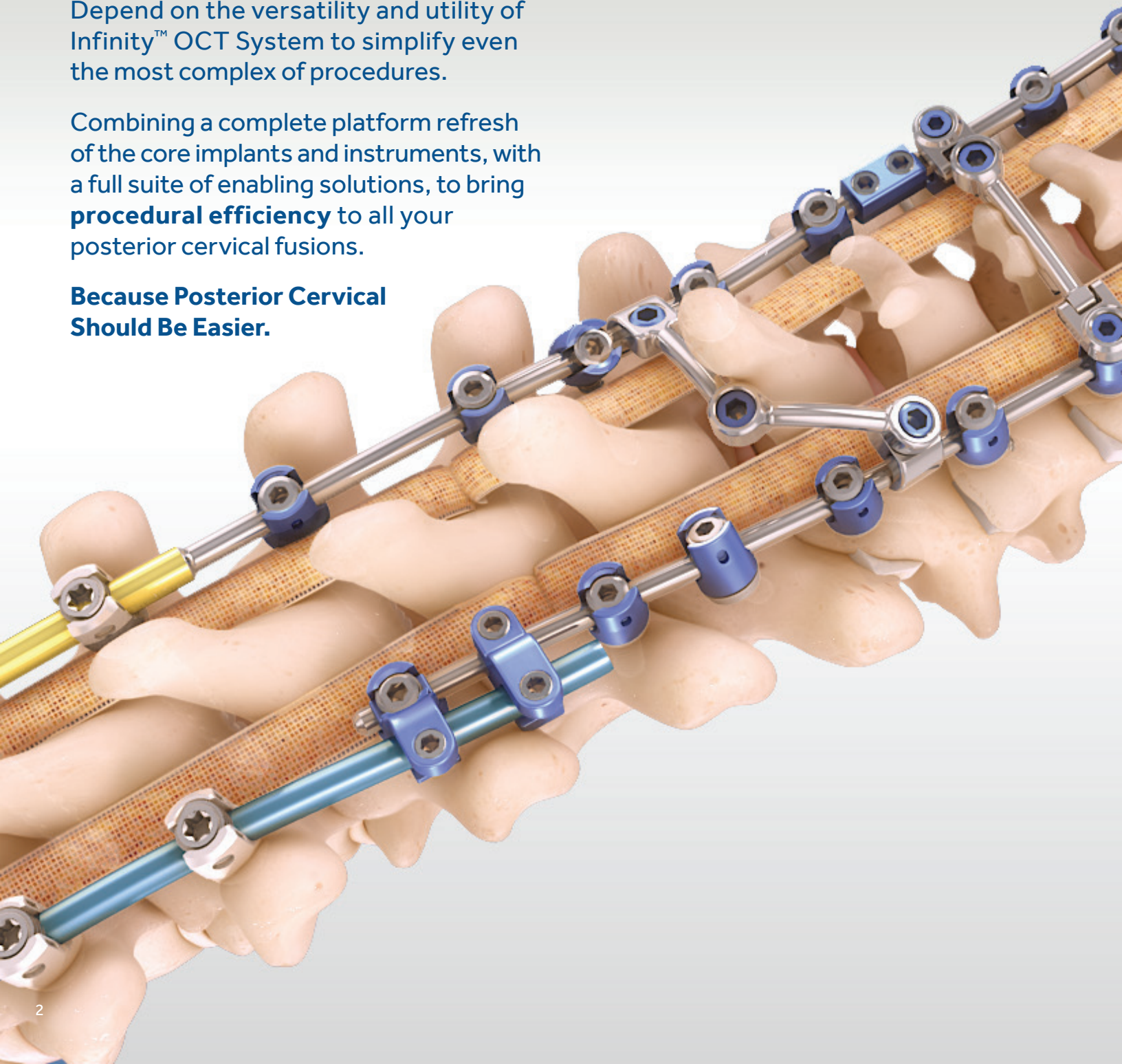

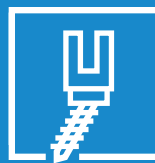
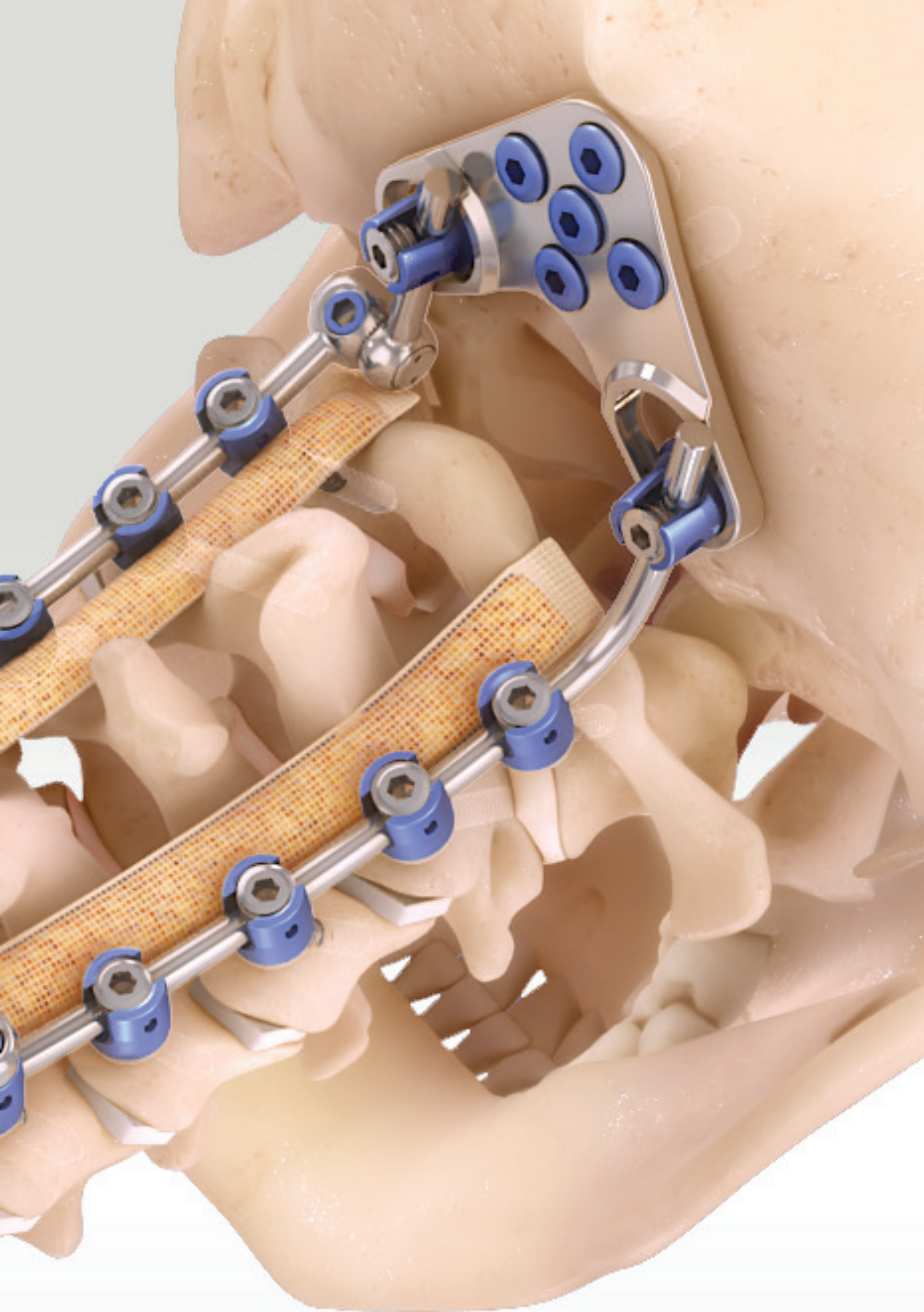

**IMPLANTS
DESIGNED FOR
EASY CONSTRUCT
CONNECTIONS**

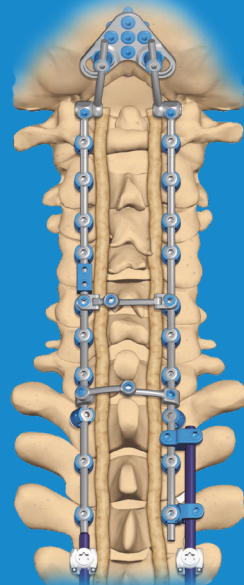

**THE RIGHT
TOOLS,
FOR SMALL
SPACES**

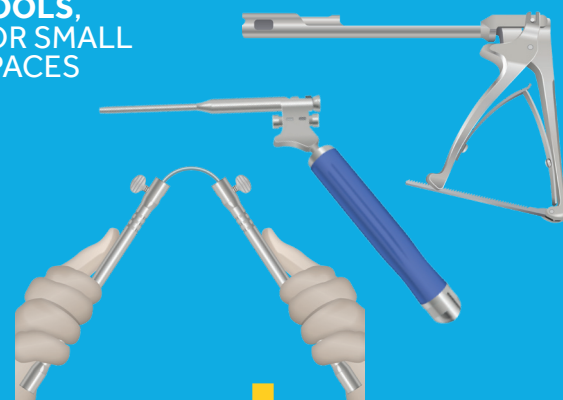
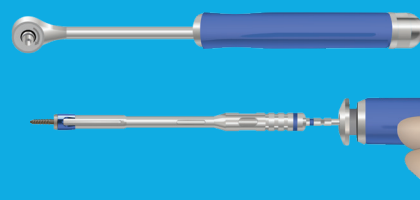

**FULLY-
ENABLED
PROCEDURES**





ENHANCED MULTI AXIAL SCREW AND SET SCREW— THE FOUNDATION OF YOUR CONSTRUCT. MADE EASIER.

Multi Axial Screw

Construct Assembly made easy
with **RodSync Technology**:

- Angulation where you need it...
with up to 60° of angulation in
ANY direction
- Easy rod capture with friction
fit saddles that maintain
position during rod placement
- Minimized rod contouring

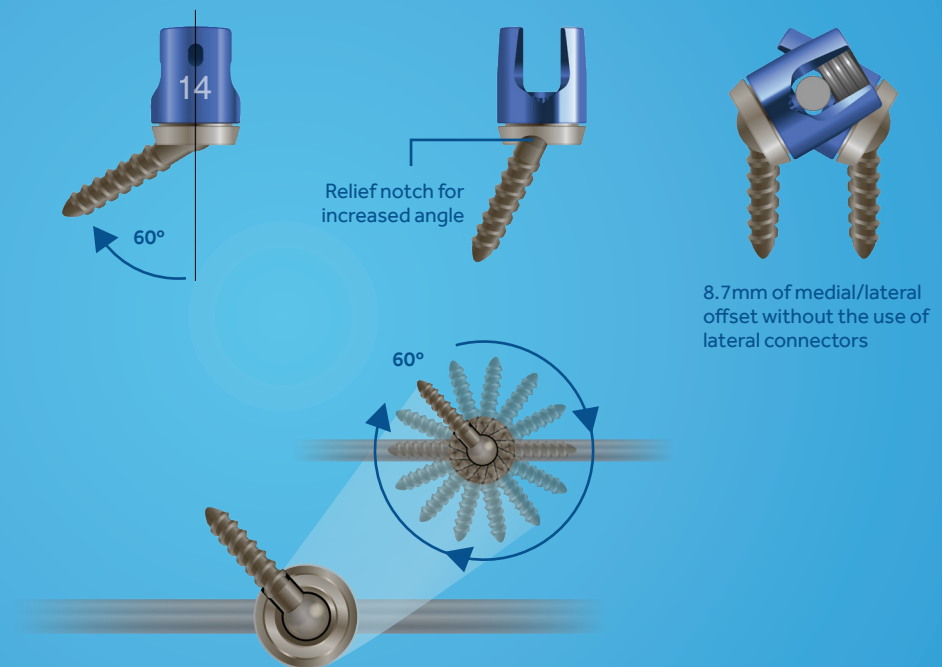



IMPLANTS DESIGNED FOR EASY CONSTRUCT CONNECTIONS

24% more full threads for increased engagement in bone and stronger tactile feel*

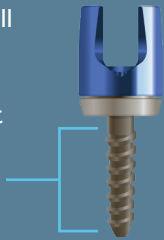

Ease of start with tapered tip that facilitates location of pilot hole and screw insertion

One screw for all rod diameters and materials for procedural and logistical efficiency

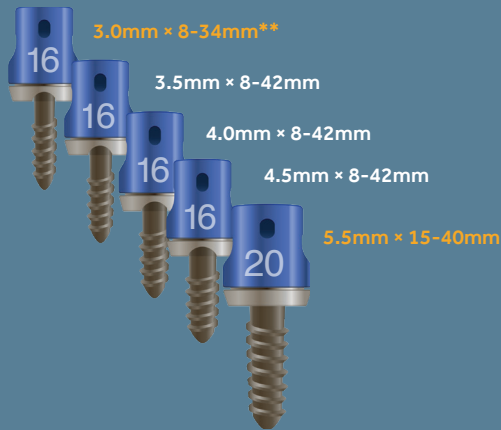

Expanded size ranges to now include a 3.0mm X-Small Cervical Screw** and 5.5mm transition screw

Partially Threaded Multi Axial Screw

Variety of diameters to accommodate unique anatomy of C1 lateral mass

Uniform 10mm of unthreaded screw shank throughout all screw lengths

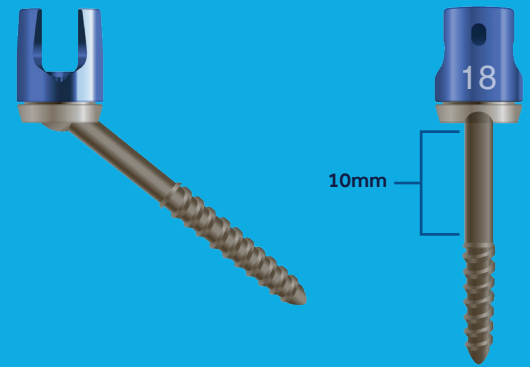

Set Screw

Designed to minimize cross threading

- Features a blunt start thread for ease of starting by reducing the chances of the set screw starting off-axis
- 114% thicker thread makes it more difficult to cross thread*

Increased interface with screwdrivers with 20% deeper hex engagement*

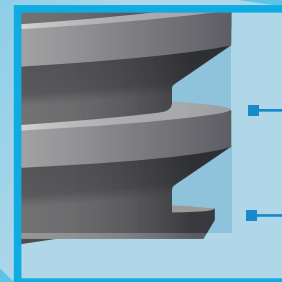
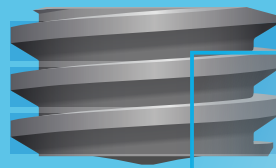

114% thicker thread crest

Quickstart lead-in thread



Did you Know?

Quickstart threads are commonly seen on fire hose couplings to minimize cross threading in emergency situations when seconds matter.

*As compared to Vertex Select™ Reconstruction System

**The 3.0mm multi axial screw (MAS) requires the use of MAS Crosslink™ at each level in which the 3.0mm screw is intended to be used



FULL SPECTRUM OF ROD DIAMETERS AND MATERIALS ACCOMMODATING VARIOUS SPINAL APPLICATIONS AND CONSTRUCT DEMANDS.

Surgeon choice of rod diameter and material to best match patient pathology and construct demands, all interchangeable with the same multi axial screw for procedural and logistical efficiency.

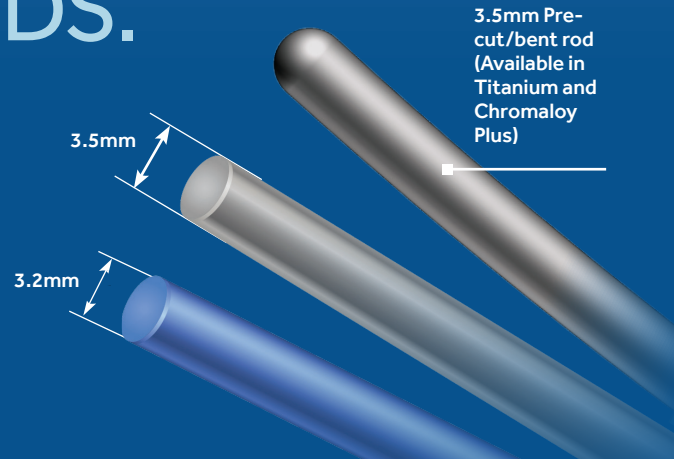

Rod Options

Rod Family Description	3.2mm Titanium	3.5mm Titanium	3.5mm Chromaloy™ Plus	3.5mm to 4.75mm, Titanium	3.5mm to 5.5mm, Titanium	3.5mm to 6.0mm, Titanium	3.5mm to 4.75mm, Chromaloy™ Plus	3.5mm to 5.5mm, Chromaloy™ Plus	3.5mm to 6.0mm, Chromaloy™ Plus
Straight Rods	■	■	■						
Pre-Cut/ Pre-Bent Rods		■	■						
Occipital Adjustable Rods (see OC section for details)		■	■						
Occipital Pre-Curved Rods (see OC section for details)		■	■						
Cervical Thoracic Tapered Rods (see OC section for details)				■	■	■	■	■	■



MULTIPLE ROD MATERIALS TO MEET VARIOUS CONSTRUCT DEMANDS

Mechanical Comparisons of Various Rod Materials

Rod Stiffness

The resistance to deformation (bend) when a force is applied.

Clinical Relevance:

Stiffness maintains stability.

Higher the stiffness of a rod, requires more force to bend.

Consider a rod with higher stiffness to maintain correction under high construct demands.

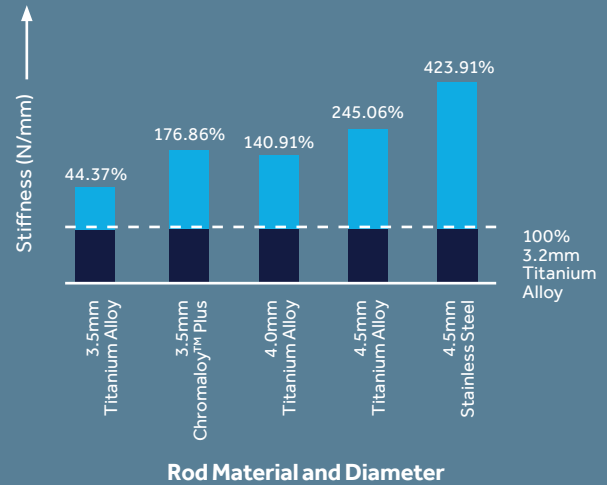

Yield Strength

The amount of force necessary to cause a permanent bend in the rod.

Clinical Relevance:

A rod with lower yield strength requires less force to permanently bend and hold its shape (i.e., less spring back).

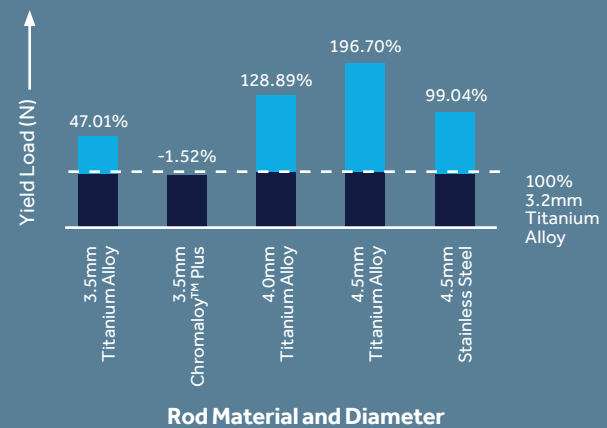

Notch Sensitivity

The tendency of notches to form in the rod.

Clinical Relevance:

Notches are indentions on the rod caused by bending, and can reduce fatigue strength of a rod and ultimately lead to rod breakage or construct failure.

Materials that are less notch sensitive can withstand higher compression fatigue loads.

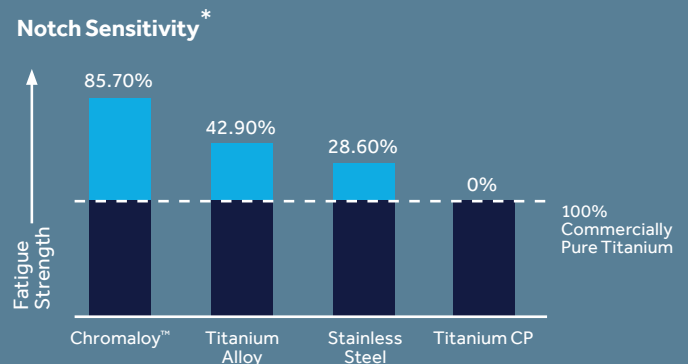

* Based on internal testing per ATSM F2193. Data on file.



VERSATILITY AT THE JUNCTIONS SIMPLIFYING THE COMPLEX WITH SEAMLESS TRANSITIONS

Multiple OC Fixation Options

Small Adjustable Plate

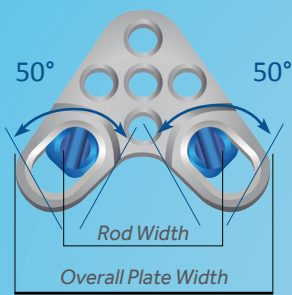

Min Rod Width	Max Rod Width	Overall Plate Width
24mm	32mm	46.9mm

Standard Adjustable Plate

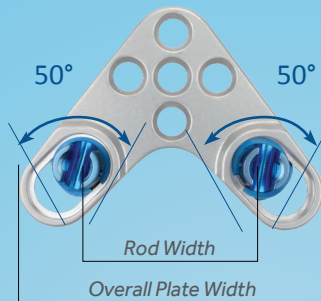

Min Rod Width	Max Rod Width	Overall Plate Width
32mm	40mm	54.75mm

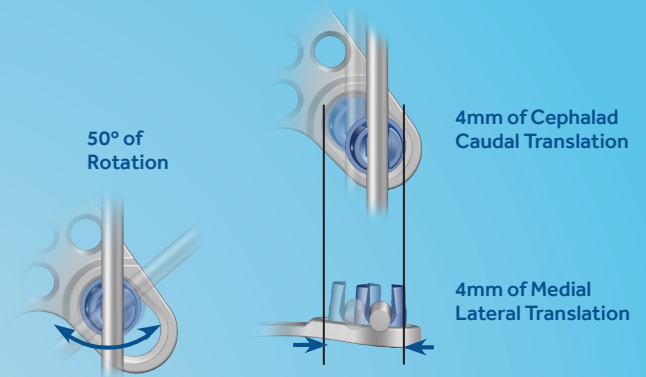

OC Adjustable Plate

- Three hole midline fixation to maximize bone purchase in the midline
- Rotating and translating saddles allow for flexibility in rod placement
- Space between saddles of the plate for bone grafting
- Pre-machined radius of curvature for proper fit onto the occipital anatomy
- Multiple Sizes

OC Screw Connectors

- Low-profile occipital fixation option
- Allows for six points of occipital midline fixation
- Flexibility in screw placement on the occiput
- Dorsal height adjustment capabilities accommodate uneven bone surfaces

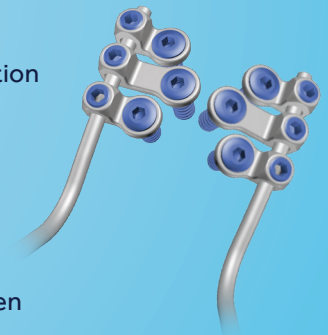



Multiple OC Rod Options to Best Fit Anatomy at the OC Junction

OC Adjustable Rods

- Hinge portion adjustability to accommodate various OCJ anatomical angles
- Angulation can be adjusted after it has been placed in the construct in order to achieve OCT alignment goals
- Reduced profile of hinge for improved fit*
- Adjustability without disassembly

OC Pre-Curved Rods

- Pre-contoured to match anatomy of the OCJ
- Low profile option for difficult anatomy

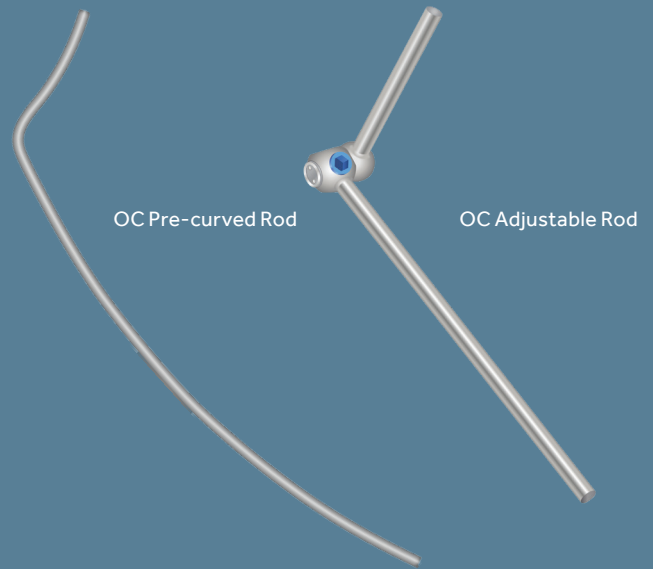

Available in Titanium and Chromaloy™ Plus

Shown to withstand higher compression and torsion loads as compared to Titanium, the metal properties and mechanical performance of Chromaloy™ Plus make this rod material a viable and preferred choice to provide increased construct strength and meet the high construct demands of OCJ procedures.

COMPRESSION FATIGUE CONSTRUCT STRENGTH



TORSION FATIGUE CONSTRUCT STRENGTH

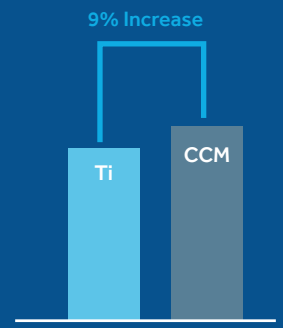

Chromaloy™ Plus OC Adjustable Rods outperformed Titanium Adjustable Rods in both compression and torsion fatigue**

Multiple OC Bone Screw Options

Standard Tip Design

- 4.5mm x 6-14mm
- 5.0mm x 6-14mm
- Increased Thread Volume

Tapered Tip Design

- 4.5mm x 6-14mm
- 5.0mm x 6-14mm

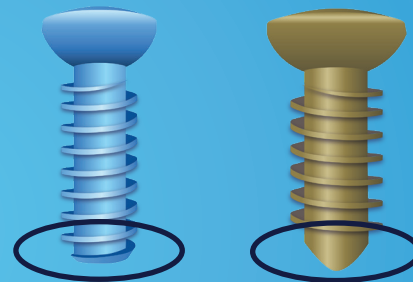

*As compared to Vertex Select™ Reconstruction System

**Based on internal test data using Titanium and Chromaloy™ Plus OC Adjustable Rods



Cervical Thoracic Transition Implants

Wide variety of transition options for flexibility in construct planning. Connecting 3.2 and 3.5mm rods to 4.75mm, 5.5mm, and newly offered 6.0mm / 6.35mm***

Cervical Thoracic Transition Rods

Transition Rods in Titanium and Chromaloy™ Plus



Shown to have greater stiffness & strength as compared to Titanium, the metal properties and mechanical performance data of Chromaloy™ Plus make this rod material a viable and preferred choice to provide increased construct strength and meet the high construct demands of CTJ procedures.

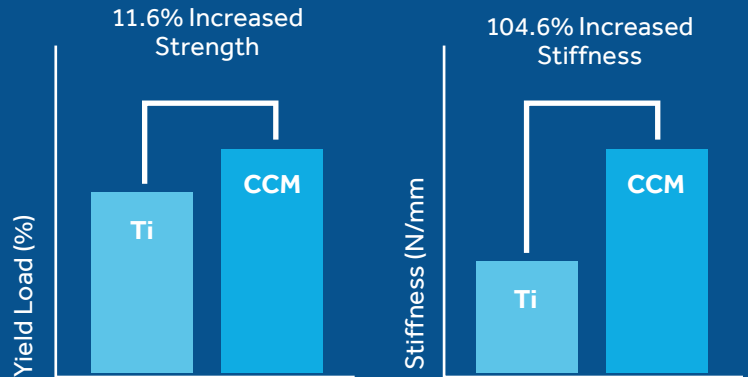

The Infinity™ Chromaloy™ Plus Tapered Rod are **11.6% stronger** and **104.6% stiffer** than the Infinity™ Titanium tapered rod in a four-point static bend test.**

Dominos

Offset Dominos

Allows for medial/lateral offsets at transition point

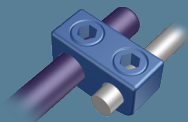

Open to Open Offset Dominos

- Enables revision/extension of a construct
- Enables dual rod constructs

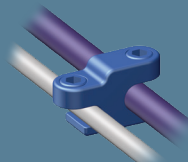

Axial Dominos

- Allows for axial alignment of rods at transition point
- Stepped design feature to accommodate dorsal height differences between rods

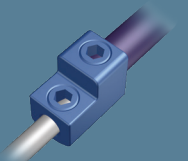

MAS Extension Connectors

- Enables revision/extension of a construct
- Enables dual rod constructs
- Zero "Run on the Rod" Transition Point
- Simplified assembly steps*

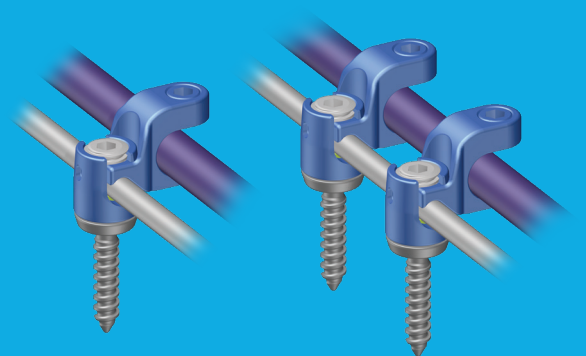

The MAS extension connectors are intended to be used with 3.5mm and larger diameter multi axial screws. The MAS extension connectors are not intended to be used with 3.0mm screws.

* As compared to Vertex Select™ Reconstruction System

** Based on internal four-point bending test data using 3.5mm to 4.75mm Titanium and Chromaloy™ Plus Tapered Rods – ASTM F2193

***O/O Offset Domino and MAS Ext Connector



OPTIMIZED CONNECTING COMPONENTS. VERSATILITY WITH SIMPLIFIED ASSEMBLY.

Multiple Crosslink Designs

Crosslink® Connector, Rod to Rod Design

- Rotating rod connection component to allow for attachment at different levels of the construct

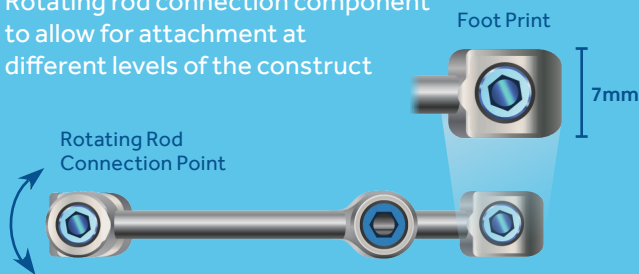

Crosslink® Connector, MAS to MAS Design

- Connects to the top of a multi axial screw head in cases where adjacent screw heads are in close proximity to one another
- With integrated connector set screw to reduce implantation steps*

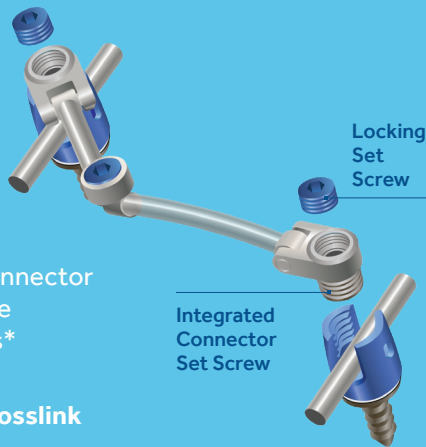

Common to both Crosslink Connector Designs

- Adjustable design and various sizes to accommodate varying distances between rods
- Lower profile at the apex of the crosslink arch*
- Internal center set screw and ability to use the MAS Counter Torque improves screwdriver interface during final tightening of the central lock.

Lateral Offset Connectors

- Dorsal height adjustment capabilities to accommodate screw height differences
- Open and Closed lateral connectors available in 10mm, 13mm, and 19mm lengths
- The lateral offset connectors are intended to be used with 3.5mm and larger diameter multi axial screws. The lateral offset connectors are not intended to be used with 3.0mm screws.



Laminar Hooks

- Available in 4.5mm and 6.0mm openings
- Available in standard and offset designs

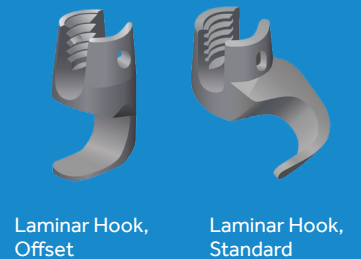

*As compared to Vertex Select™ Reconstruction System



**THE RIGHT TOOLS,
FOR SMALL SPACES**

**THE RIGHT
TOOLS, FOR
SMALL SPACES.**

**VISIBILITY.
FUNCTIONALITY.
EXPERIENCE.**



**SEE MORE,
IN A SMALL SPACE**



**DO MORE,
IN A SMALL SPACE**

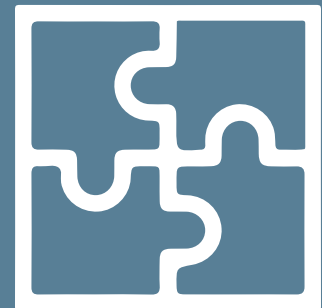

**SOLVE FOR MORE,
IN A SMALL SPACE**



THE RIGHT TOOLS, FOR SMALL SPACES

SEE MORE, IN A SMALL SPACE

Reduced length and profile for improved line of site and closer position to anatomy*

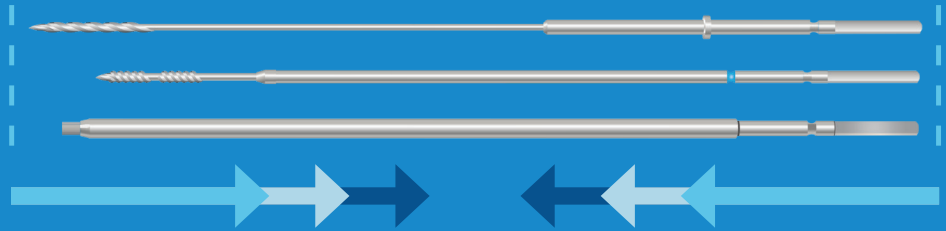

DO MORE, IN A SMALL SPACE

Screw Hole Prep

Fixed drill guides for the most common size screws

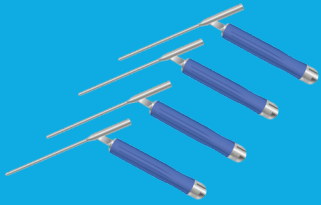

Optimized Adjustable Drill Guide

- Reduced length and barrel size*
- Enhanced locking mechanism*
- Easily identifiable depth markings



Taps with easily identifiable depth markings

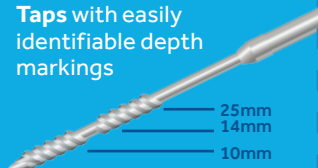

Probes in both straight and curved geometries to optimize fit in the pedicles



Screw Insertion / Alignment

Screwdrivers designed for improved engagement and release of MAS

- New Self-Holding Sleeve Driver
- Self-Holding and Threaded Screwdrivers with optimized interfaces
- 20% deeper hex engagement*



Increased Angle Positioner to direct the additional angulation of the MAS where it's needed

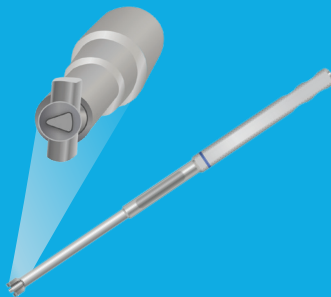

Rod Manipulation

Rod Reducer with self-aligning mating features and open barrel design to promote ease of alignment and engagement with MAS.



Rod Bender with adjustments to bending wheels to allow for short segment rod bending.

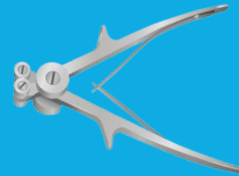

Rod Cutter for in situ cutting



Final Tightening

Optimized Final Tightening Experience

Torque Limiting Screwdrivers

- Increased engagement with set screw*
- Length reduction facilitates alignment with set screw

Counter Torques

- Tighter "fit" on MAS for more control*



*As compared to Vertex Select™ Reconstruction System



**SOLVE FOR MORE,
IN A SMALL SPACE**

More tools to address the challenging anatomy of the **Occipitocervical Junction***

New OC Drill Tap Guides and Screw Guide



Screw Guide end for additional control during OC bone screw insertion



New OC Torque Limiting Drivers:

- Right Angled Ratchet Torque Driver for efficiency during final tightening
- Flexible and Straight Torque Drivers

New OC Rod Pusher / Counter Torques:

- 45 degree and 90 degree angle positions
- Flexibility in placement on any of the OC implants

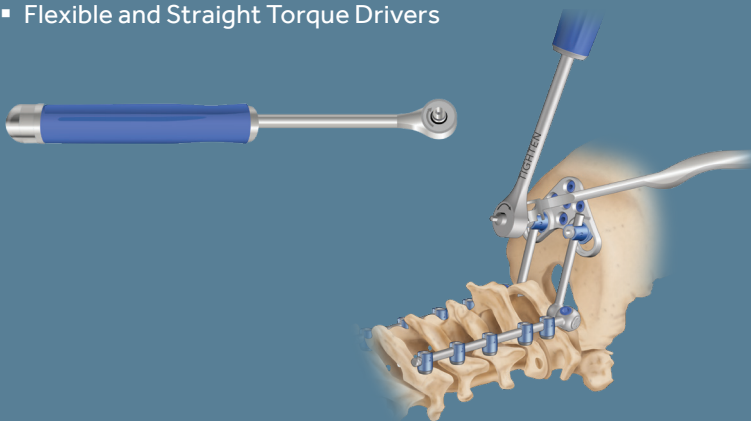

OC Tube Benders:

Provides an additional rod bending option for the increased rod curvature needed specifically at the occipitocervical junction

New OC Plate Bender:

Create bends in the OC plate for an anatomic fit against the occiput.

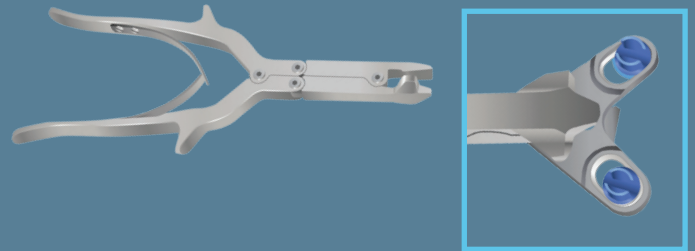
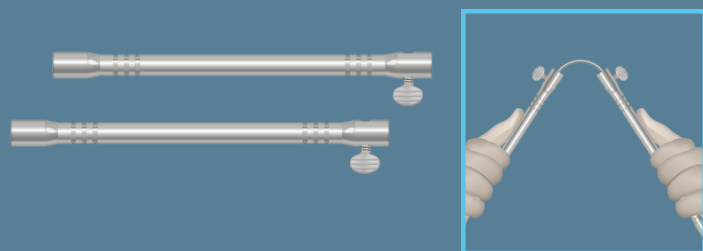

*As compared to Vertex Select™ Reconstruction System



BRINGING FULLY ENABLED SOLUTIONS TO YOUR OR. PRECISION. CONFIDENCE. INTEGRATION.

Synergy PCF with Navigated Infinity™ OCT System

Medtronic's Surgical Synergy spinal workflow streamlines your procedures by eliminating certain intraoperative steps.

Reduction in radiation exposure to near zero

Increased surgeon confidence with precise screw trajectories and placement

Refined Set of Navigated Instruments

- Designed for the posterior cervical-upper thoracic working space
- Reduced length and profile for improved line of site and closer position to anatomy with all guides, drills, taps, and drivers *
- Longer drilling depths*
- Drill Guide with NavLock Positioner for efficiency in holding the NavLock Tracker

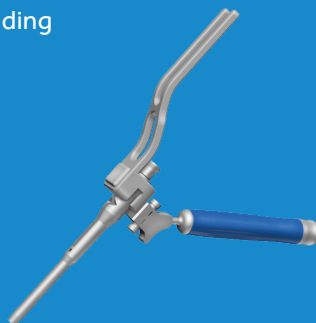
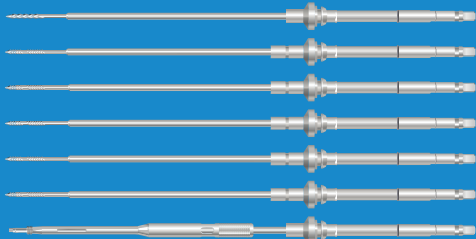

*As compared to Vertex Select™ Reconstruction System



Powerase™ Compatible

- Procedural efficiency through system integration
- Navigated Drill Bit, Taps, and Driver integrated with The Powerase™ System



Neuromonitoring Integration

- Early warning/detection to help avoid neural injury/compromise
- Aids in the efforts to reduce instances of C5 nerve root palsy (brachial plexus)
- Using multi-modality intraoperative monitoring (MEPs/SSEPs) has been shown to help reduce iatrogenic injury to somatic sensory & motor systems.



Biologics Solutions that Empower

DEGENERATIVE SHORT CONSTRUCT

Surgeons that desire
CONTAINMENT



Mastergraft™ Strip



Mastergraft™ Matrix EXT

Surgeons that desire
PACKABILITY



Mastergraft™ Putty



Grafton™ DBM DBF

Mastergraft™ Strip, Mastergraft™ Putty and Mastergraft™ Matrix

- Osteoconductive
- Cell carrier

DEFORMITY LONG CONSTRUCT

Surgeons that desire
CONTAINMENT



Magnifuse™ DBM

Magnifuse™ DBM

- Osteoconductive fibers
- Offers containment
- Performance driven by high osteoinductivity

Surgeons that desire
PACKABILITY



Grafton™ DBM DBF

Grafton™ DBM DBF

- Osteoconductive fibers
- Performance driven by high osteoinductivity

INDICATIONS

The INFINITY™ OCT System is intended to provide immobilization and stabilization of spinal segments as an adjunct to fusion for the following acute and chronic instabilities of the craniocervical junction, the cervical spine (C1 to C7), and the thoracic spine from T1-T3:

- Traumatic spinal fractures and/or traumatic dislocations.
- Instability or deformity.
- Failed previous fusions (e.g. pseudarthrosis).
- Tumors involving the cervical spine.
- Degenerative disease, including intractable radiculopathy and/or myelopathy, neck and/or arm pain of discogenic origin as confirmed by radiographic studies, and degenerative disease of the facets with instability.

The INFINITY™ OCT System is also intended to restore the integrity of the spinal column even in the absence of fusion for a limited time in patients with advanced stage tumors involving the cervical spine in whom life expectancy is of insufficient duration to permit achievement of fusion.

In order to achieve additional levels of fixation, the INFINITY™ OCT System may be connected to the CD HORIZON™ Spinal System and VERTEX™ Reconstruction System rods with the INFINITY™ OCT System rod connectors. Transition rods with differing diameters may also be used to connect the INFINITY™ OCT System to the CD HORIZON™ Spinal System. Refer to the CD HORIZON™ Spinal System package insert and VERTEX™ Reconstruction System package insert for a list of the indications of use.

Note: The 3.0mm multi axial screw (MAS) requires the use of MAS CROSSLINK™ at each level in which the 3.0mm screw is intended to be used.

The lateral offset connectors and MAS extension connectors are intended to be used with 3.5mm and larger diameter multi axial screws. The lateral offset connectors and MAS extension connectors are not intended to be used with 3.0mm screws.

RISKS

Along with the benefits of this technology, there are also potential risks. Risks associated with the INFINITY™ OCT System include, but are not limited to:

- Disassembly, bending, and/or breakage of any or all of the components
- Pressure on the skin from the component parts which could cause skin penetration, irritation, and/or pain, tissue or nerve damage, and/or scar formation

INDICATIONS

Magnifuse™ Bone Graft is intended for use as a bone graft substitute in bony voids or gaps of the skeletal system (i.e., spine, pelvis and extremities) not intrinsic to the stability of the bony structure. The voids or gaps may be surgically created defects or defects created by traumatic injury to the bone.

Magnifuse™ Bone Graft may be used in a manner comparable to autogenous bone or allograft bone. Magnifuse™ Bone Graft may be mixed with fluid such as bone marrow aspirate, blood, sterile water, or sterile saline in order to adjust the consistency and handling characteristics of the bone graft material. Magnifuse™ Bone Graft is resorbed/remodeled and replaced by host bone during the healing process.

CONTRAINDICATIONS

The following are contraindications for the use of Magnifuse™ DBM Bone Graft and Magnifuse™ II Bone Graft:

- The presence of infection at the transplantation site.
- Treatment of spinal insufficiency fractures.

INDICATIONS

GRAFTON™ DBM and GRAFTON PLUS™ DBM are intended for use as a bone graft extender, bone graft substitute, and bone void filler in bony voids or gaps of the skeletal system (i.e., spine, pelvis, and extremities) not intrinsic to the stability of the bony structure. The voids or gaps may be surgically created defects or defects created by traumatic injury to the bone. GRAFTON™ DBM (excluding the Orthoblend form) and GRAFTON PLUS™ DBM are also intended to be packed into bony voids or gaps to fill and/or augment dental intraosseous, oral, and cranio-/maxillofacial defects. These defects may be surgically created osseous defects or osseous defects created from traumatic injury to the bone, including periodontal/infrabony defects; alveolar ridge augmentation (sinusotomy, osteotomy, cystectomy); dental extraction sites (ridge maintenance, implant preparation/placement); sinus lifts; cystic defects; craniofacial augmentation. GRAFTON™ DBM and GRAFTON PLUS™ DBM may be used alone in a manner comparable to autogenous bone chips or allograft bone particulate (demineralized

freeze dried bone), or they may be mixed with either allograft or autograft bone or bone marrow as a bone graft extender. GRAFTON™ DBM and GRAFTON PLUS™ DBM are indicated only for bony voids or gaps that are not intrinsic to the stability of the bony structure. GRAFTON™ DBM and GRAFTON PLUS™ DBM are absorbed/remodeled and replaced by host bone during the healing process. Note: The user should consider the fact that GRAFTON™ DBM CRUNCH contains demineralized bone chips approximately 3 mm (±1 mm) in determining the appropriateness of this allograft for use in small defects.

CONTRAINDICATIONS

The following are contraindications for the use of GRAFTON™ DBM and GRAFTON PLUS™ DBM:

- The presence of infection at the transplantation site.
- Treatment of spinal insufficiency fractures.

INDICATIONS

Caution: GRAFTON™ DBM DBF is restricted to use by a physician, podiatrist, or dentist. GRAFTON™ DBM DBF can be used in orthopedic or reconstructive bone grafting procedures. The product can also be used in bone grafting procedures in combination with autologous bone or other forms of allograft bone, or alone as a bone graft. The contents of an individual GRAFTON™ DBM DBF container are intended for single patient use only. Do not use the contents of any container for multiple patients. Empty or partially used containers should be disposed of in accordance with recognized procedures for discarding medical waste materials. Preparation of the bone graft bed is important for graft incorporation and bone formation, as are other factors such as blood supply, source of marrow elements, loading, stability, and absence of infection at the graft site. The volume of graft material used in each procedure is determined by the judgment of the clinician.

CONTRAINDICATIONS

The presence of infection at the transplantation site is a contraindication for the use of this allograft.

Medtronic

Medtronic

Spinal and Biologics Business
Worldwide Headquarters

2600 Sofamor Danek Drive
Memphis, TN 38132



Medtronic Sofamor Danek USA, Inc.

1800 Pyramid Place
Memphis, TN 38132

(901) 396-3133

(800) 876-3133

Customer Service: (800) 933-2635

The surgical technique shown is for illustrative purposes only. The technique(s) actually employed in each case will always depend upon the medical judgment of the surgeon exercised before and during surgery as to the best mode of treatment for each patient.

Please see the package insert for the complete list of indications, warnings, precautions, and other important medical information.



Consult instructions for use at this website www.medtronic.com/manuals.

Note: Manuals can be viewed using a current version of any major internet browser. For best results, use Adobe Acrobat® Reader with the browser.

©2018 Medtronic. All Rights Reserved. Medtronic, Medtronic logo and Further, Together are trademarks of Medtronic. All other brands are trademarks of a Medtronic company. UC201809527 PMD021072-1.0

medtronic.com