

VIPER[®] 2

MIS Spine System
Adaptable MIS solutions
for an evolving practice



This publication is not intended for distribution in the USA.

SYSTEM GUIDE

SURGEON DESIGNERS

D. Greg Anderson, MD

Thomas Jefferson University Hospital
Rothman Orthopaedics
Philadelphia, PA

Robert Heary, MD

University of Medicine & Dentistry New Jersey
Newark, New Jersey

Carl Laurysen, MD

Tower Orthopedic & Neurosurgical Spine Institute
Beverly Hills, CA

Tony Tannoury, MD

Boston University Medical Center
Boston, MA

Professor Cornelius Wimmer, MD

Behandlungszentrum Vogtareuth
(Vogtareuth Treatment Center)
Vogtareuth, Germany

CONTRIBUTING SURGEONS

Dirk Alander, MD
John Asghar, MD
Eric Belanger, MD
Randal Betz, MD
Ashok Biyani, MD
Andrew Cannestra, MD
Mitch Hardenbrook, MD
Bradley Heiges, MD
Marty Herman, MD
Doug Linville, MD

Steve Ludwig, MD
Paul Park, MD
Kees Poelstra, MD
Khalid Sethi, MD
John Shiau, MD
Harry Shufflebarger, MD
Jonathan Song, MD
Mike Wang, MD
Faissal Zahrawi, MD

TABLE OF CONTENTS

SYSTEM OVERVIEW	3
DEGENERATIVE	4
DEFORMITY	6
TRAUMA	10
TUMOR	14
SURGICAL TECHNIQUE	
	Pedicle Targeting 16
	Guidewire Placement 19
	Pedicle Preparation 21
	Tap Pedicle 23
	Screw Loading 24
	Screw Insertion 27
	Rod Measuring 30
	Conventional Rod Insertion 32
	Advanced Rod Insertion 34
	Set Screw Insertion 38
	Rod Approximation using the VIPER 2 Rod Approximator 39
	Rod Approximation with the X-Tab Reduction Screws 42

	Compression/Distractor	43
	Rod Holder Removal	44
	Final Tightening/Counter-Torque	45
	Screw Extension Removal	47
	X-Tab Removal	49
<hr/>		
PRODUCT CATALOG	Instruments	50
	Cases and Trays	52
	Rods	53
	Screws	55
	Instruments, Cases and Trays	57
	Screws	58
	Guide Wires	61
<hr/>		
INDICATIONS AND USAGE		65

SYSTEM OVERVIEW

The VIPER 2 System is the evolution of minimally invasive Spine Surgery. Building upon the intuitive design and techniques established by the original VIPER System.

By delivering a comprehensive range of instrumentation and implant options, the VIPER 2 System provides surgeons with the confidence and control required to address more advanced indications with a less invasive approach.

Born from the EXPEDIUM® Spine System and evolved from the VIPER System, the VIPER 2 System takes percutaneous fixation to the next level.

Degenerative

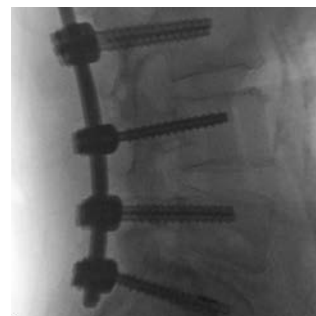

Deformity

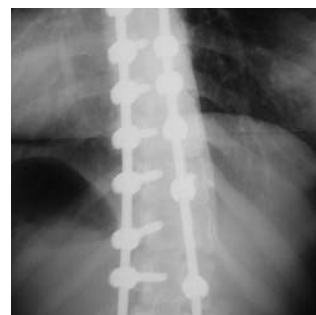

Trauma

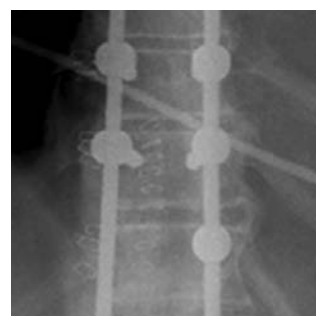

Tumor

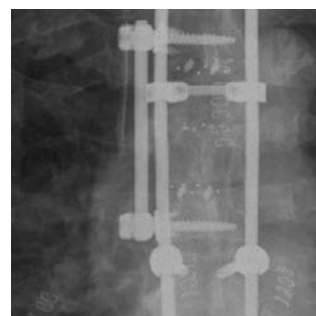

DEGENERATIVE

A FASTER, SIMPLER APPROACH TO PERCUTANEOUS DEGENERATIVE FIXATION

Streamlined Rod Placement

Simple and repeatable rod placement through two stab incisions

Insert and Rotate

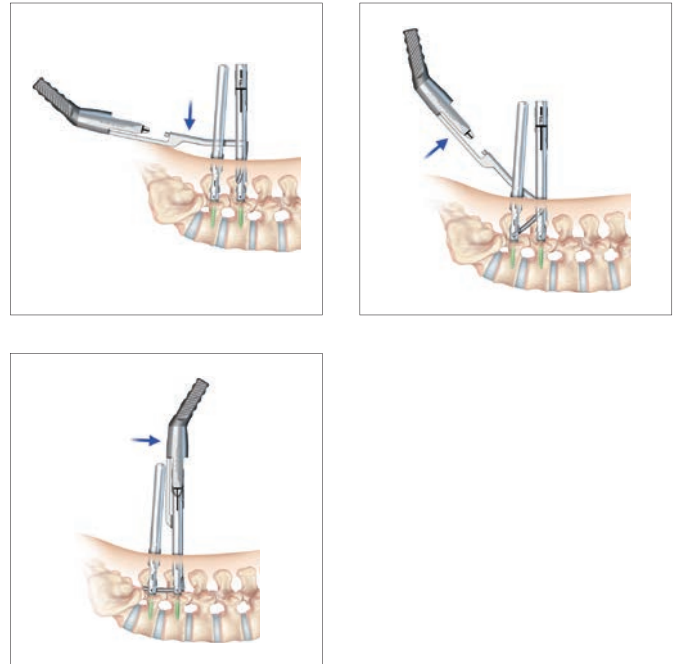

Minimal Muscle Trauma

A truly percutaneous technique minimizes unnecessary incisions and tissue trauma

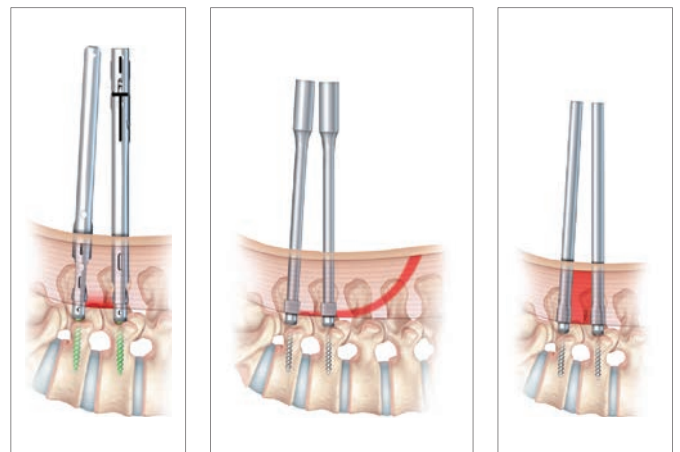

VIPER 2

Competitor 1

Competitor 2

Simple Percutaneous Reduction Options

Comprehensive internal rod reduction options to simplify even the most difficult cases without compromising the incision size

Pistol-Grip Reducer

Quickly connect to any VIPER 2 Extension for easy one-step internal reduction

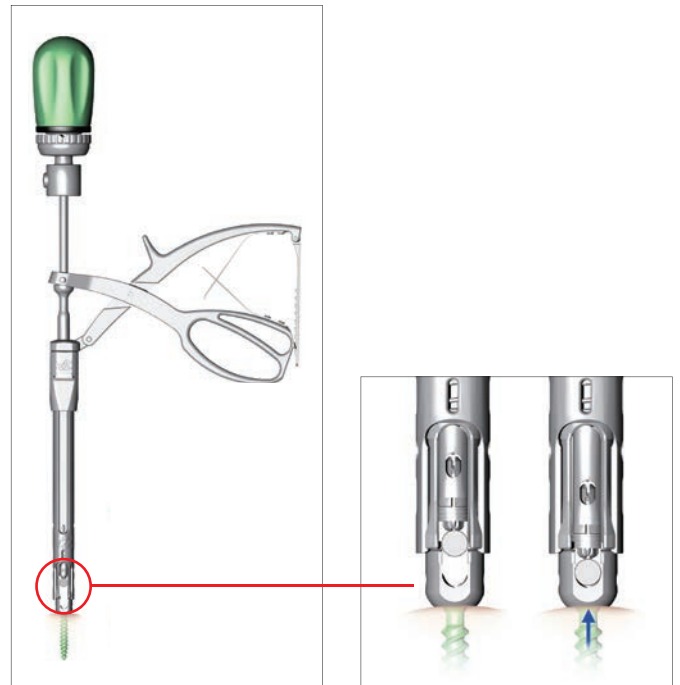

X-Tab Screw (Extended Tab Reduction Screw)

VIPER 2 X-Tab Implants bring integrated reduction tab technology to MIS surgery

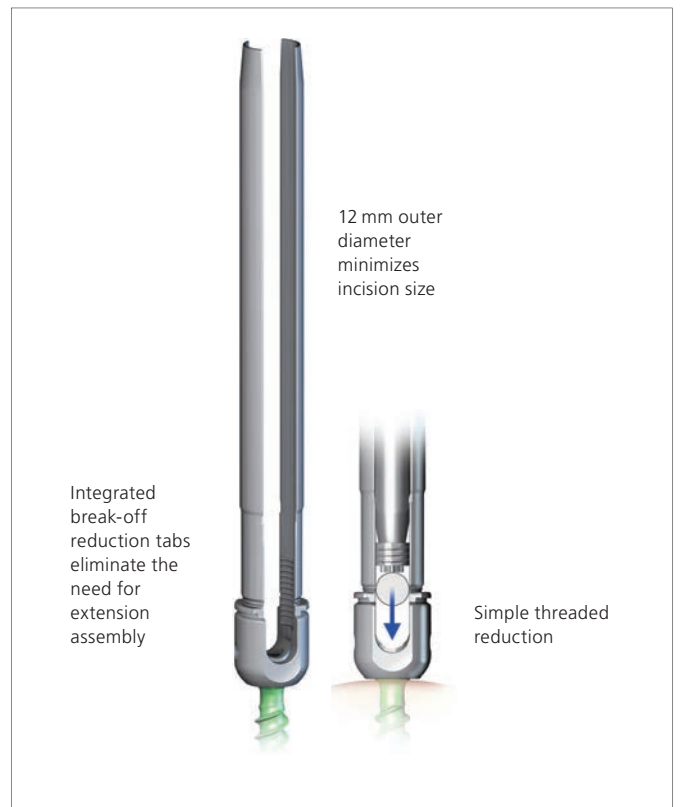

DEFORMITY

PERCUTANEOUS SHORT SEGMENT ADULT DEFORMITY TREATMENT USING THE VIPER 2 SYSTEM

D. Greg Anderson, MD
Thomas Jefferson University,
Department of Orthopedics

History of Present Illness and Radiographs

- 57 year old male presented with a bilateral back, buttock and thigh pain and reports symptoms had progressively worsened for the last 5 years
- The patient had been treated with physical therapy, NSAIDS and epidural injections, but these treatments had become ineffective over the last year
- Imaging revealed the presence of a 30° degenerative scoliotic curve in the lumbar spine (Figures 1 and 2)

Treatment Method and Materials

- Interbody fusions and releases of the deformity were performed at the L2–L5 disc spaces using a lateral approach
- The patient was then flipped and the SPOTLIGHT tubular retractor system was used to posteriorly decompress areas of lateral recess stenosis at the L2–L5 levels. Bilateral decortication of the facet joints for fusion was also performed at L2–L5 at this time
- Using the same skin incisions, seven percutaneous VIPER pedicle screws were placed under fluoroscopic guidance at the L2, L3 (unilateral), L4 and L5 levels
- Two 200 mm straight VIPER 2 rods were cut and contoured using the tops of the screw extensions as a guide
- The rods were placed percutaneously and once in place, VIPER 2 reduction and compression instruments were used to help correct the sagittal and coronal alignment
- The total anesthesia time for both stages of the surgery was 4.5 hrs and the blood loss was 150 cc



Figures 1 and 2: AP and Lateral Views

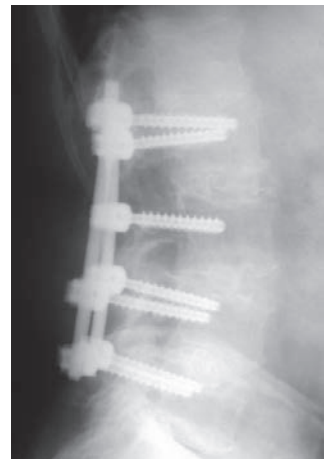
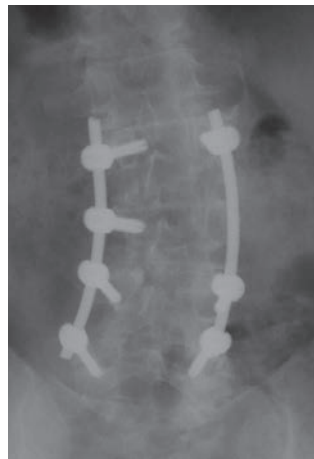

Figures 3 and 4: AP and Lateral Views of the Spine at the 1-year Postoperative Visit

Follow-up Results

- Patient was mobilized to a chair the evening of surgery and discharged on postoperative day two
- By post-op week two, he reported good relief of his pre-operative symptoms and was able to resume normal work functions, including attending a conference in another state by week three
- At one year, radiographs demonstrated a solid fusion at all operative levels (Figures 3 and 4)
- Presently, he reports excellent pain relief and has resumed an active lifestyle

The VIPER 2 System allows for minimally invasive treatment of adult degenerative scoliosis, while still achieving satisfactory reconstruction and alignment. The decreased muscle trauma afforded by the system allowed this patient to quickly return to normal activities.

THE CONFIDENCE TO TREAT DEFORMITY WITH AN MIS APPROACH

Versatile and Secure Correction Solutions

Connection Strength

- VIPER 2 Extension and Rod Holder technology are designed to withstand the demands of deformity correction

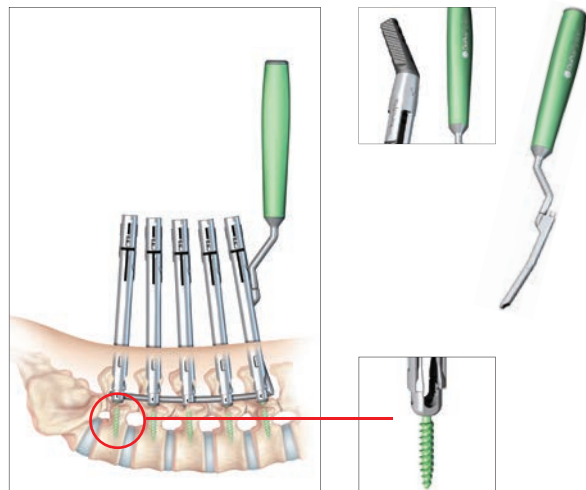

VIPER 2 extension connection strength allows for vertebral body manipulation before or after rod insertion

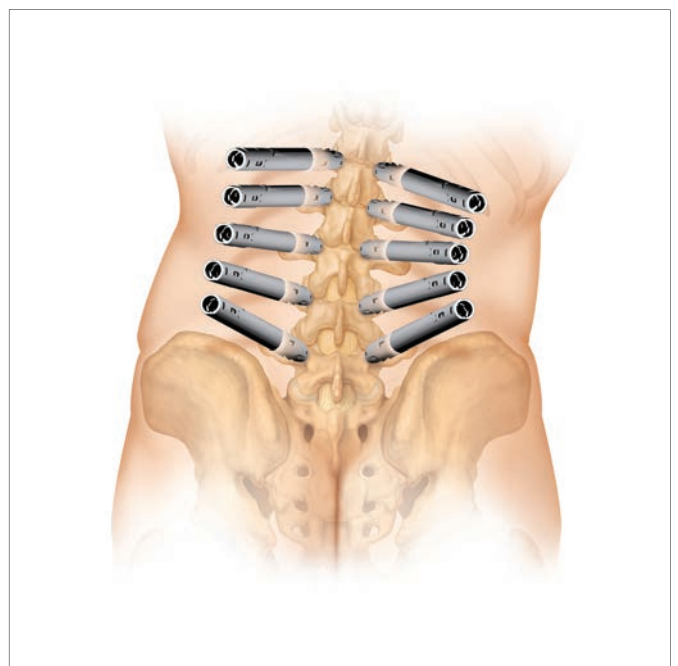

Hex-End Rod Design

Bulletheaded VIPER 2 Hex-End Rod and novel connection feature provide 360° of percutaneous rod rotation control during and after rod placement

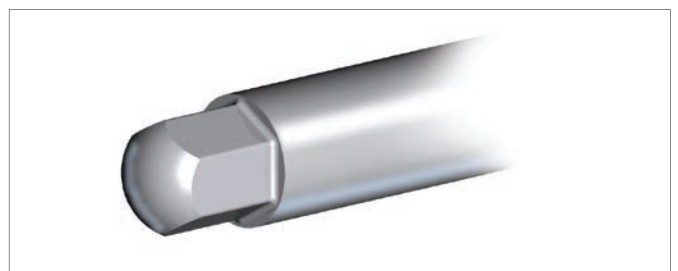

Powerful Internal Approximation Options

- Pistol Grip Approximation provides quick, intuitive rod reduction without bulky external sleeves
- VIPER 2 X-Tab Screws offer the simplicity and control of integrated threaded reduction in an ultra-low profile design

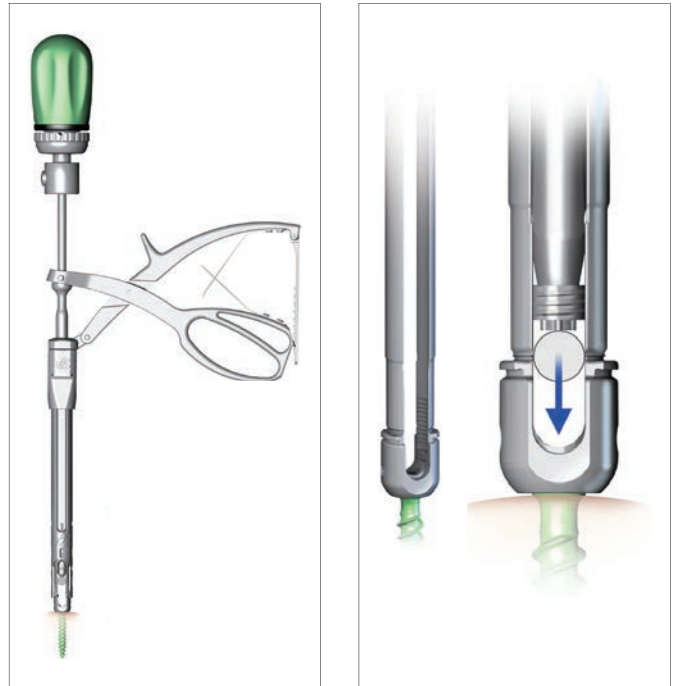

Low-Profile Instrument Design

VIPER 2 Extensions and X-Tab Screws designs are optimized to reduce instrument crowding and incision size for complex surgery

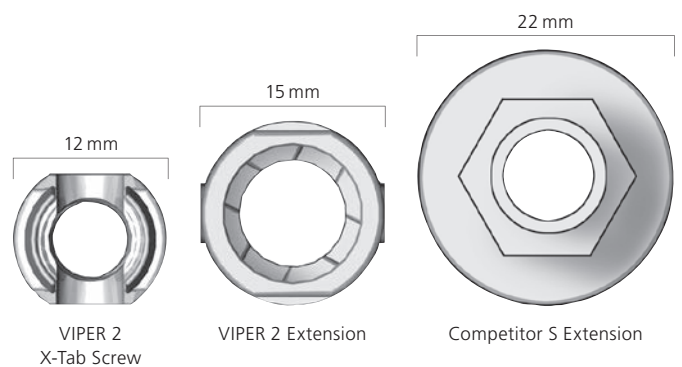

PERCUTANEOUS SPINAL TRAUMA TREATMENT USING THE VIPER 2 SYSTEM

Tony Tannoury, MD
Boston University,
Department of Orthopedics

History of Present Illness and Imaging

- A 48 year old male construction worker arrived at the ER after falling from a three story building
- The patient was neurologically intact but demonstrated signs of bilateral leg weakness
- Imaging revealed L1 and L2 burst fractures with a severely compromised canal at both levels (Figures 1, 2, and 3)

Treatment Method and Materials

- An anterior corpectomy was performed at L1/L2 and an 80 mm mesh cage was inserted into the space left from T12 to L3
- A unilateral anterior EXPEDIUM rod and screw construct was inserted laterally from T12 to L3 to support the anterior column
- Nine percutaneous VIPER screws were placed bi-laterally at every level from T12 to L4 except in the left pedicle on L1
- Bilateral 120 mm VIPER 2 rods were placed percutaneously starting from T12 (Figures 4 and 5) to L4
- OR time for the posterior portion of the case was approximately 75 minutes with 75 cc of blood loss and no complications



Figure 1: Lateral CT Scan

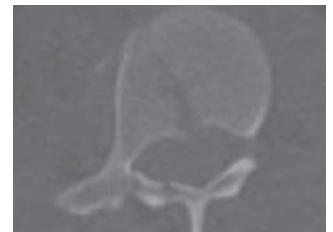

Figure 2: Axial CT of L1

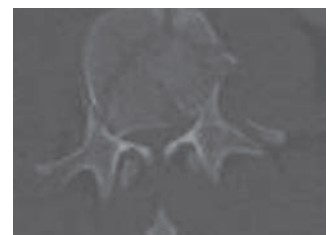

Figure 3: Axial CT of L2



Figure 4: Post-op Lateral Radiograph

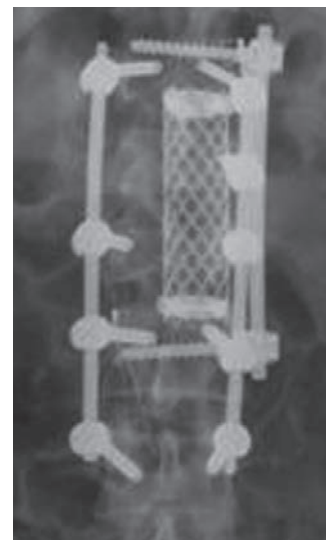

Figure 5: Post-op A-P Radiograph

Follow-up Results

- The patient was ambulating on post-operative day three and was discharged on day four
- At the time of discharge, the patient reported almost no posterior muscle pain despite the 5-level instrumentation
- At six months post-op, the patient was back to normal function and had no signs of adjacent level degeneration or post-traumatic alignment issues
- The patient has no complaints of incisional or muscle pain and the skin incisions were observed to have healed completely at six months

The VIPER 2 System's percutaneous posterior fixation allowed us to fully stabilize this patient's spine while contributing to little blood loss, minimal posterior muscle damage and a fast recovery.

VERSATILITY FOR THE DEMANDS OF MIS TRAUMA STABILIZATION

The Importance of Slot Height for Spinal Trauma

Speed and Security of Rod Delivery through Proximal Extension

- VIPER 2 Extension Slots allow controlled rod passage through the proximal extension, eliminating the uncertainty of rod insertion through a remote incision
- Immediate rod capture confirmation provides the surgeon the confidence to quickly advance the VIPER 2 Rod through multiple extensions



Flexibility to Deliver any Curvature Rod

Optimized Slot Height allows simple passage of kyphotic, lordotic, or dual curve rods

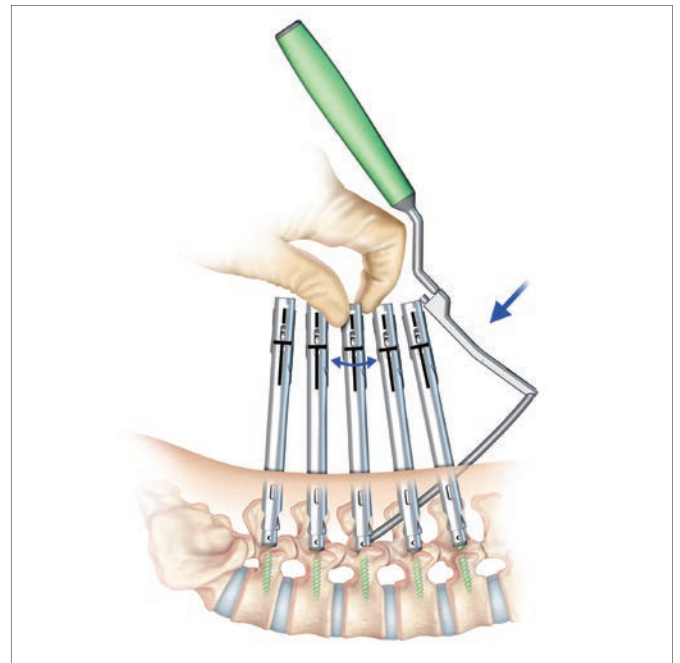

Rod Options

VIPER 2 Rods come in straight, lordosed and kyphosed configurations from 30 mm–600 mm

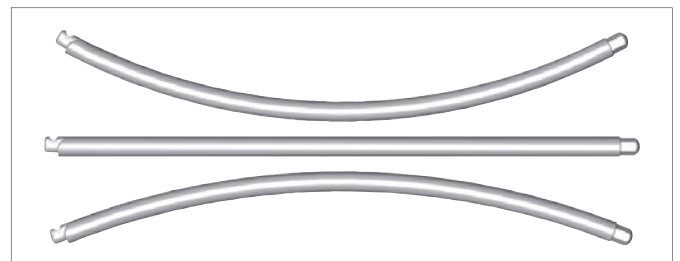

TUMOR

STREAMLINED MIS POSTERIOR FIXATION FOR TUMOR SURGERY

Versatility to Instrument the Entire Thoracolumbar Spine

- A wide range of rod options for kyphotic and lordotic curves
- Truly percutaneous rod introduction options optimized for short and long segments

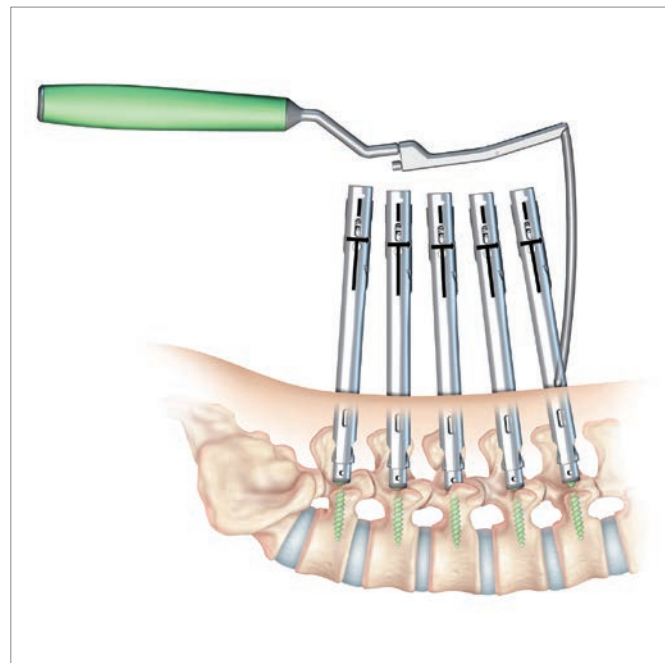

Full compatibility with the DePuy Synthes Spine EXPEDIUM® 5.5 System for hybrid construct options

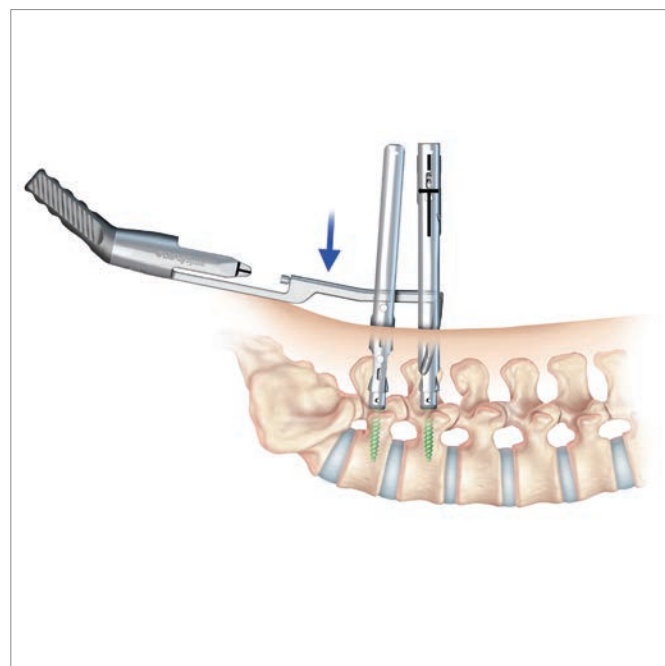

Percutaneous Revision Options

VIPER 2 screw extensions can be quickly re-attached in-situ to revise and extend constructs

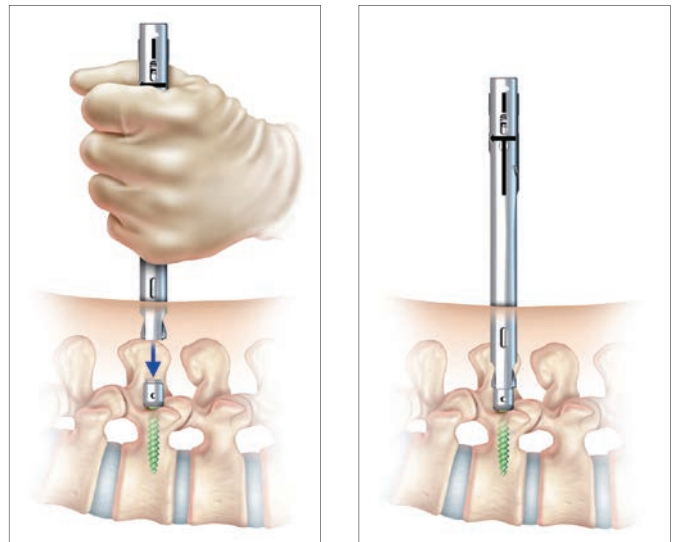

Elegance of the X-Tab Screw Design

- 12 mm outer diameter minimizes skin incision and muscle trauma
- Built-in threaded reduction for easy rod approximation
- Integrated break-off reduction tabs eliminate the need for extension assembly

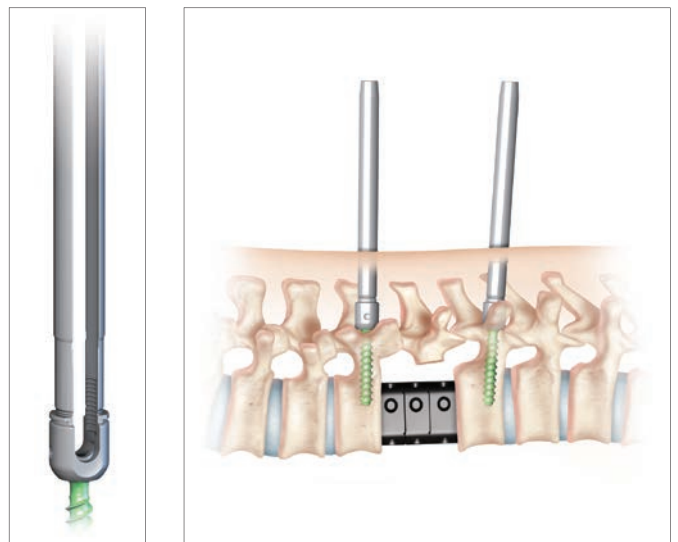

SURGICAL TECHNIQUE

PEDICLE TARGETING

OR Set-Up

- The patient should be positioned prone lying face down on a radiolucent table
- It is recommended to use a Jackson Table, to assist in achieving the proper patient positioning and an unrestricted fluoroscopic view. Confirm the C-Arm will allow for easy rotation in the lateral, oblique, and A/P positions around the table
- Tables that prohibit unobstructed A/P and lateral images should not be used for this procedure



Fluoroscopic Planning

- Use A/P and lateral fluoroscopy to identify and target the appropriate level(s)
- Ensure that the C-Arm is positioned correctly for each targeted level by adjusting the position of the C-Arm until both endplates are parallel and the spinous process is equidistant from the center of each pedicle when viewed on A-P fluoroscopy
- The C-Arm may need to be repositioned for each appropriate level

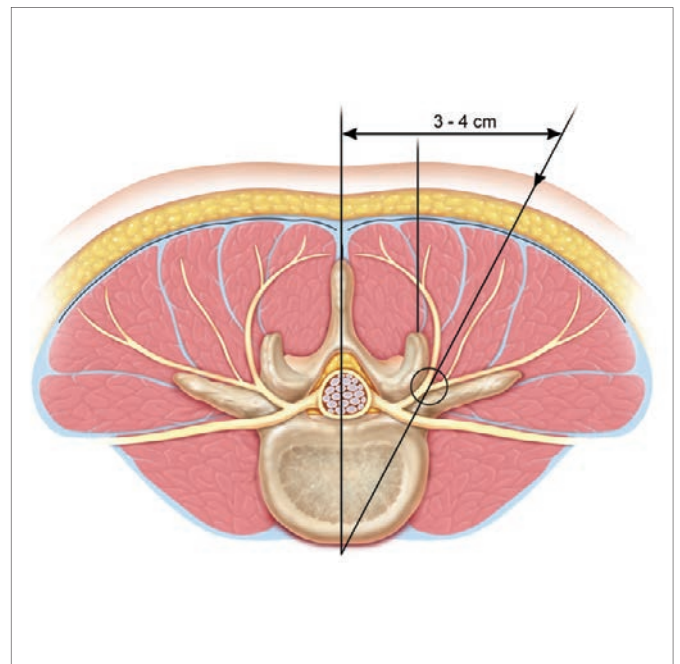

Determine the Skin Incision Location

- Place a guidewire on the patient perpendicular to the axis of the spine at the targeted level. Using A-P fluoroscopy, position the guidewire such that its projection transects the center of both pedicles in the cephalad-caudal direction. Use a surgical marker to transfer that plane to the patient
- Place guidewires on the patient parallel to the axis of the spine. Using A-P fluoroscopy, position the guidewire such that its projection aligns to the lateral pedicle wall of the targeted level and the adjacent levels. The lateral pedicle wall of adjacent levels may also be estimated at this time. Use a surgical marker to transfer this plane onto the patient
- The skin incision for each level should be at least 1 cm lateral to the intersection of the two lines. This distance may vary depending on the size of the patient

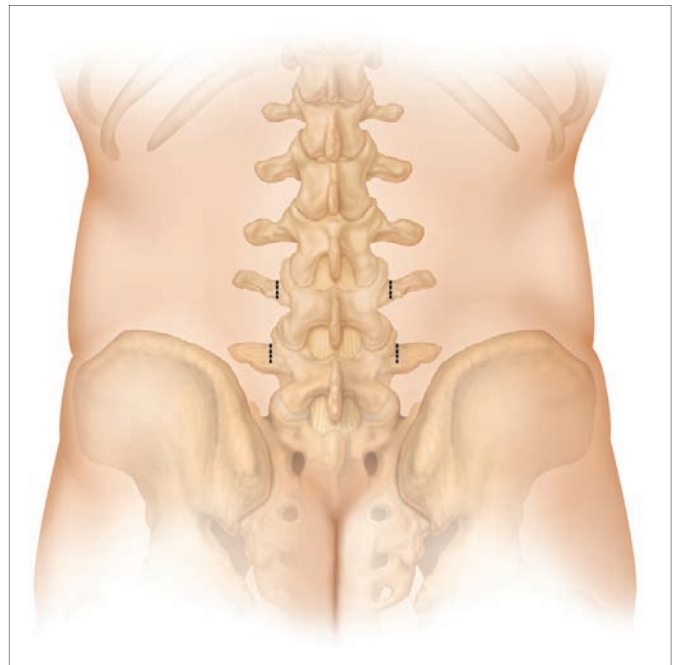

Jamshidi needle placement

- A longitudinal incision about 1.5 cm is made through the skin and fascia. (An incision of 1.5 cm will match the diameter of the Screw Extensions used later in the procedure). Insert the Jamshidi Needle through incision and dock the tip on the bony anatomy of the desired level. Confirm the position by using lateral fluoroscopy
- Using A-P fluoroscopy, advance the Jamshidi Needle to the pedicle entry point at the intersection of the facet and transverse process. Confirm that the tip of the Jamshidi Needle is at the center of the lateral border of the pedicle on an A-P image. Gently tap the Jamshidi Needle to engage the trocar tip into the pedicle

Tip: Using a surgical marker, draw a line on the Jamshidi Needle approximately 20 mm proximal to the patient's skin. When this mark is flush with the patient's skin, the distal end of the needle should be through the typical pedicle and into the vertebral body

- Advance the Jamshidi needle through pedicle using A-P fluoroscopy to direct the tip towards the center of the pedicle. The needle should not advance more than three quarters of the way across the pedicle, starting from the lateral edge of the pedicle. Continue advancement until the needle enters the vertebral body. Confirm the placement with A/P and lateral fluoroscopy to ensure that the Jamshidi Needle does not breach the wall of the pedicle
- Remove the inner stylet of the Jamshidi Needle

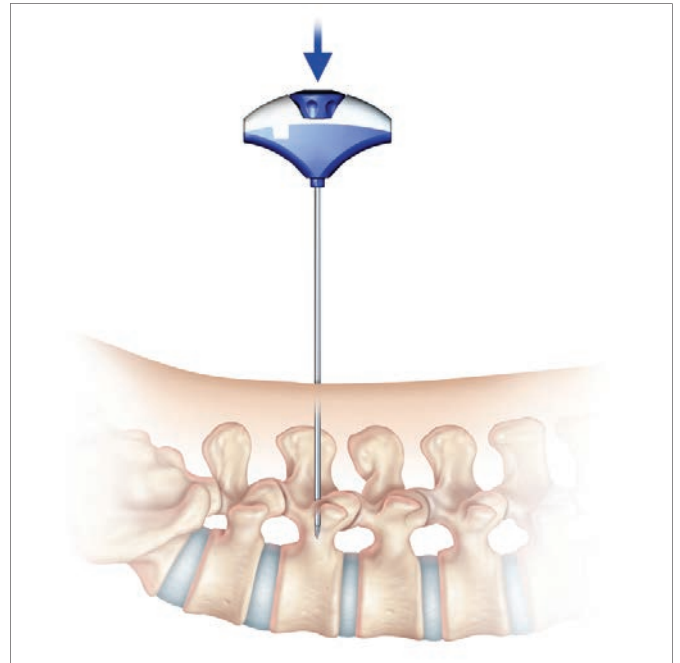

GUIDEWIRE PLACEMENT

- Select a guidewire with either a sharp or blunt tip, based on surgeon preference. Insert the guidewire into the Jamshidi Needle. Advance the guidewire beyond the tip of the Jamshidi Needle (approximately 20 mm) to ensure an adequate fixation into the cancellous bone. Confirm the placement with A/P and lateral fluoroscopy to ensure that the guidewire does not breach the wall of the pedicle or the vertebral body

Tip: To ensure proper depth, drive the guidewire by clamping a needle driver (forceps) onto the guidewire 20 mm proximal to the Jamshidi handle and impacting the forceps until the needle driver contacts the Jamshidi

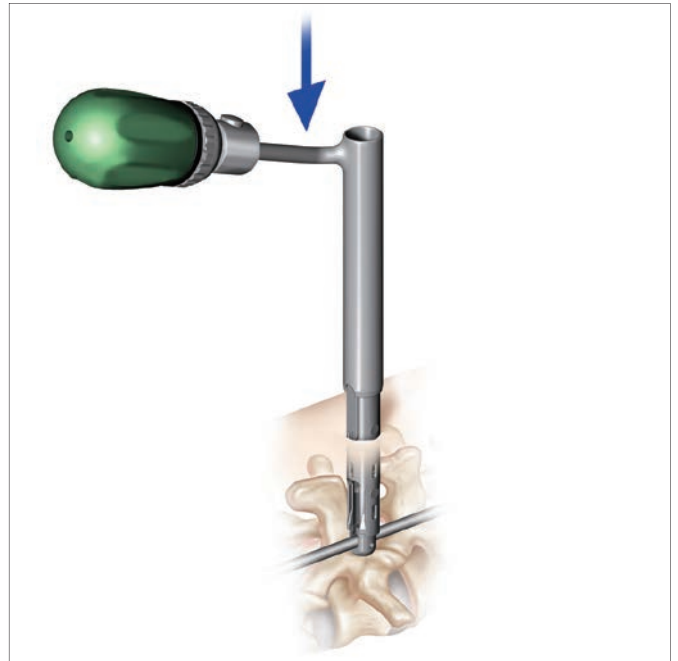

- Use caution when placing the guidewire. Markings on the wire designate 5 mm increments and can be used to determine penetration depth. Additionally, the depth markers can be used to monitor unintentional guidewire advancement or rotation
- Once the guidewire is placed to the desired depth, carefully remove the Jamshidi Needle while holding the guidewire

Note: For multi-level constructs it is recommended to place ALL guidewires prior to inserting Pedicle Screws.

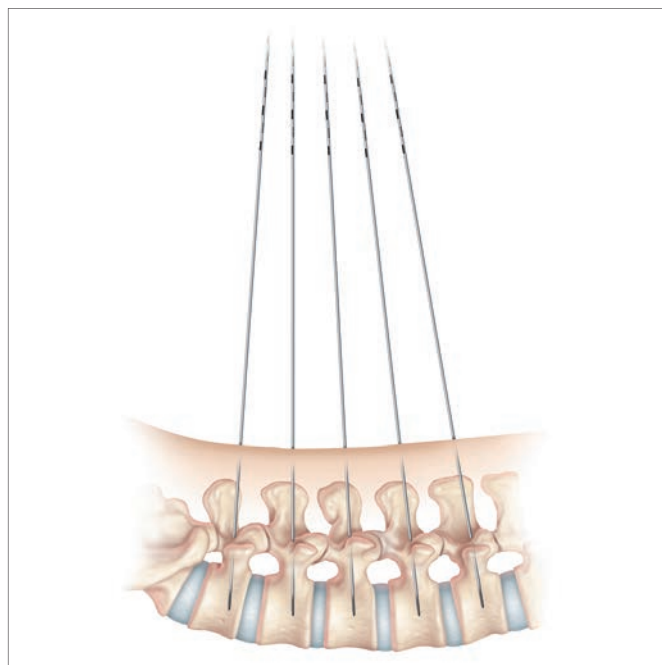
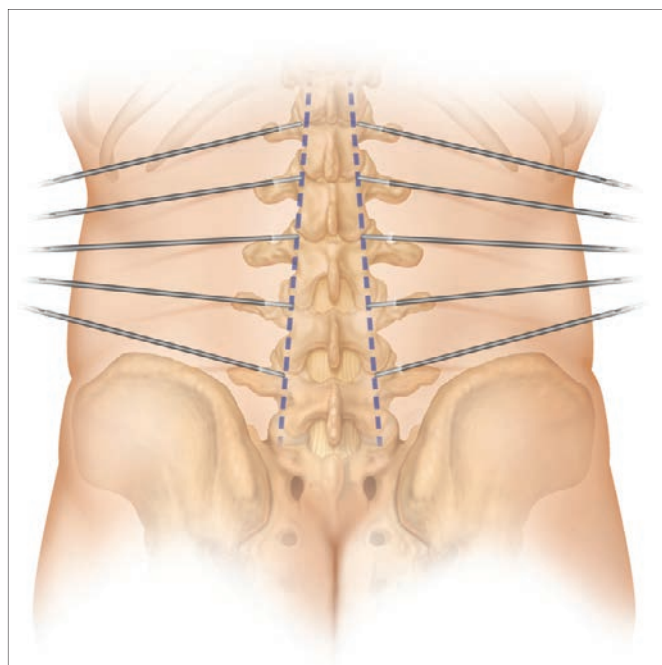

PEDICLE PREPARATION

Two options are provided for dilating soft tissue in preparation for tapping

Option 1: A Combined Dilator/Cannula

- Insert the 7 mm dilator with handle into the Pedicle Preparation Cannula and rotate with downward pressure until the two pieces “snap” and lock together
- Advance the combined instrument over the guidewire until the distal tip of the instrument contacts the pedicle. Confirm the placement with fluoroscopy. Push down on the outer cannula until it separates from the 7 mm dilator and contacts the bone. Remove the dilator while holding the guidewire and the cannula in place
- Advance the appropriate sized Cannulated Self-Drilling Tap over the guidewire and into the outer cannula. Proceed to the Pedicle Tapping section of this surgical technique

Note: VIPER 2 taps are undersized to the corresponding screw size by 0.5 mm to ensure optimal screw purchase. Hence, a 6 mm tap is actually 5.5 mm in diameter. Undersizing the tap may result in difficulty starting the screw. The corresponding tap size should be used for the chosen screw diameter.

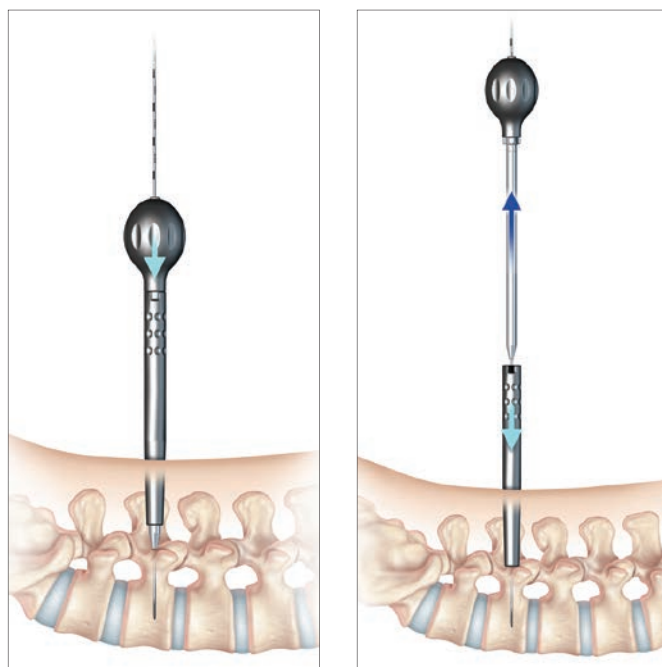

Option 2: Tap Sheath

- Depress the Unlock button on the side of the Tap Sheath and insert the Cannulated Self-Drilling Tap into the top of the sheath. Advance the tap until the horizontal marking on the tap shaft aligns with the top of the sheath, then rotate until the vertical markings align with those on the sheath. Depress the Lock button to secure the assembly together. The Cannulated Self-Drilling Tap and the Tap Sheath should now be coupled
- Verify that the tap does not move relative to the sheath while the Lock button is engaged
- Advance Tap Sheath assembly over the guidewire until the distal end of the tap contacts the pedicle. Confirm the position with fluoroscopy. Depress the Unlock button and proceed to the Pedicle Tapping section of this surgical technique



TAP PEDICLE

- While controlling the tap sheath or the tap cannula, advance the appropriate size Cannulated Self-Drilling Tap over the guidewire into the pedicle by turning the tap in a clockwise manner. Depth markings on the proximal half of the tap can be used to determine the tap depth and appropriate screw length
- While tapping, care should be taken to avoid unintentional guidewire advancement or rotation. Do not advance the tap beyond the tip of the guidewire as doing so may result in unintentional wire removal. Use caution not to bend or kink the guidewire while advancing the tap
- It is recommended that fluoroscopy be used while tapping to monitor the depth of the tap and ensure the guidewire is not unintentionally advanced

Note: VIPER 2 taps are undersized to the corresponding screw size by 0.5 mm to ensure optimal screw purchase. Hence, a 6 mm tap is actually 5.5 mm in diameter. Undersizing the tap may result in difficulty starting the screw. The corresponding tap size should be used for the chosen screw diameter.

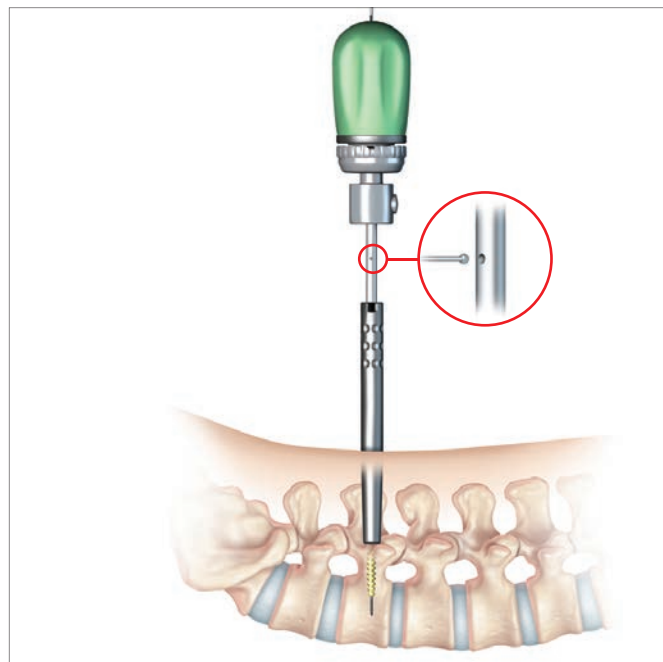
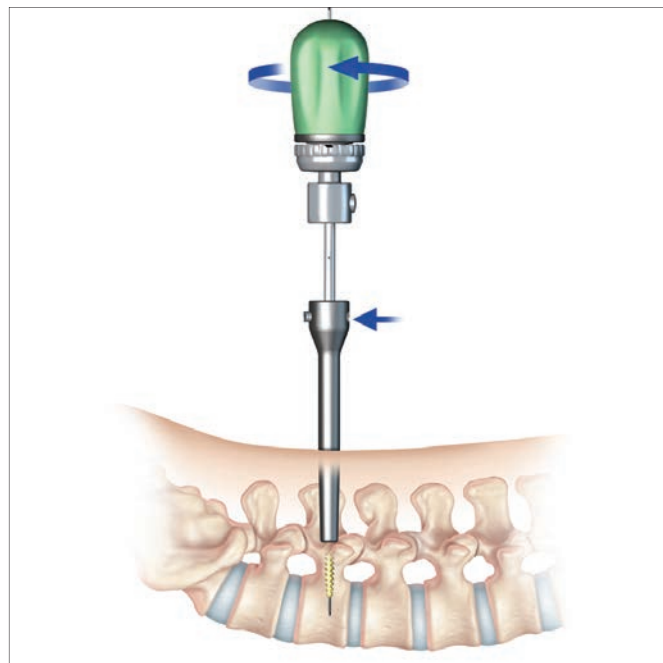

SCREW LOADING

Choose the appropriate length, diameter, and type of screw. There are two screw types:

Use the appropriate loading procedure described below for each type of screw



Cannulated X-tab Screws

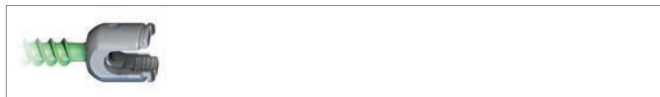

Cannulated VIPER Screws



VIPER 2 Closed Extension



VIPER 2 Open Extension

Cannulated Polyaxial VIPER Screws with Extensions

Prior to attempting to attach a Screw Extension to a screw, ensure the Castle Nut is fully loosened by turning it counterclockwise with the Castle Nut Tightener



Open both hinged doors on the appropriate screw caddy exposing the top of the Screw Heads. Ensure that all of the Screws are fully seated in the caddy. Guide the Alignment Block into the grooves located in the top of the caddy until it is fully seated

Note: The loading block **MUST** be fully seated in order to function properly

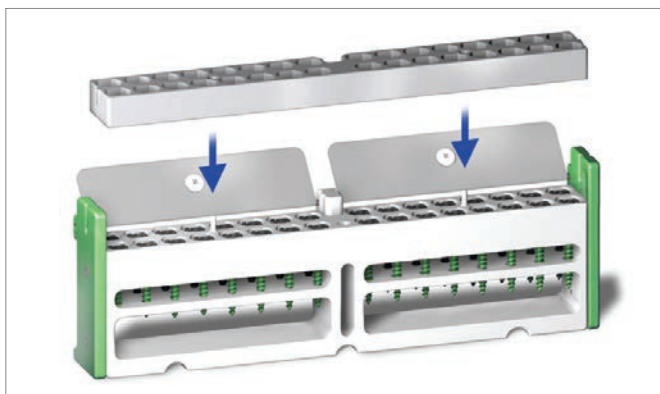

Insert the Screw Extension through the Alignment Block Assembly. Press down firmly to engage the Extension with the Screw Head. An audible “pop” will signal that the Extension is provisionally attached to the TOP NOTCH® Feature on the Screw Head

Note: If excessive resistance is encountered, double check the fit of the Alignment Block, ensure that the Castle Nut is fully loosened and verify that the force applied is vertical

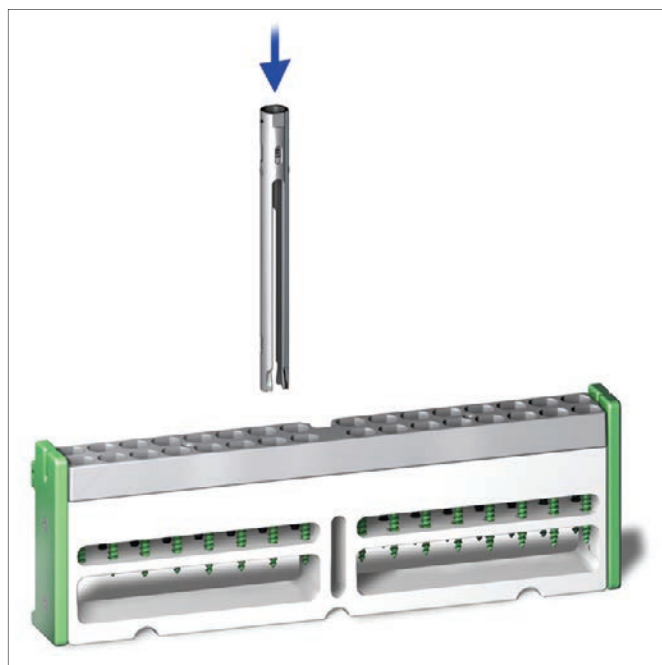

Alternatively, a small plastic mallet may be used to deliver a quick strike to the top of the extension for loading

- Remove the Screw Extension and check the provisional attachment by lightly tugging on the screw while holding the Extension and verifying that the screw is aligned with the Extension. Once this has been verified, use the Castle Nut Tightener to fully secure the screw to the Screw Extension. Use caution to avoid over tightening



Cannulated Polyaxial Extended Tab (X-Tab)

Reduction VIPER Screw Loading

Guide an X-Tab Sleeve over the tabs of the screw until it is fully seated against the Screw Head. This sleeve will help prevent unintentional separation of the tabs from Screw Heads. If resistance is encountered, ensure that the sleeve is properly aligned with the tabs

SCREW INSERTION

Insert the appropriate Polyaxial Driver into the assembly and thread the instrument into the Screw Head rotating clockwise until it stops. This step should align the Screw Shank with the extended tabs and lock the polyaxial motion of the screw

Note: An insertion sleeve **MUST** be placed over the tabs of the screw prior to insertion. This will allow for greater manipulation of the screw and prevent premature detachment of the tabs

Note: If using an Open Screw Extension, the reinforcement post should be inserted to provide increased stability and to reduce tissue hang-ups



Guide the first Screw Extension assembly over a guidewire down to the pedicle and thread the polyaxial screw into the pedicle. The guidewire should be removed as soon as the screw is through the pedicle and enters the vertebral body. While inserting the screw into the pedicle, monitor the markers on the guidewire to avoid unintentional advancement and rotation

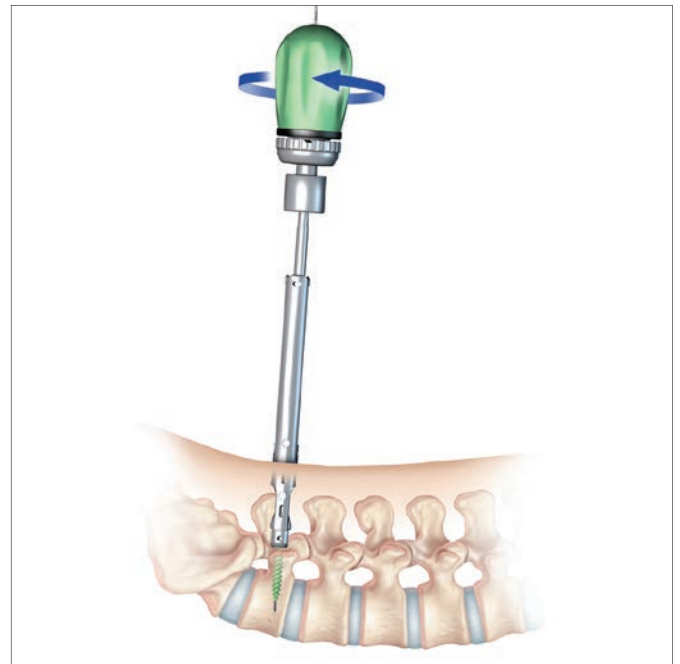

- To maintain full polyaxial capability, the Screw Head should not be fully seated against the bone
- Once the screw is inserted to the desired depth, remove the Polyaxial Driver or X-Tab Polyaxial Driver by turning the handle counterclockwise while firmly holding the Screw Extension or Extended Tab assembly. Verify polyaxial capability by manipulating the Screw Extension

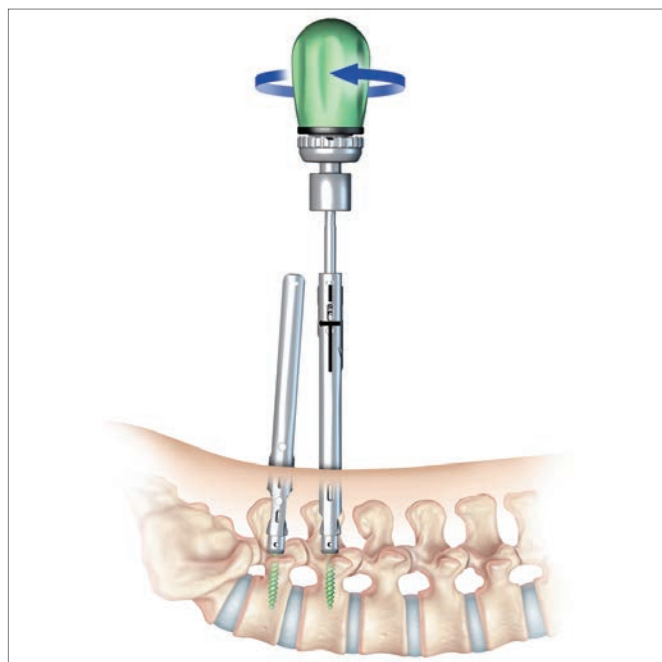

The height of each screw must be set appropriately to accommodate the curvature of the rod. Screw height can be verified with lateral fluoro or by checking the alignment of the top of the extensions. For single level constructs, confirm that the Screw Heads are at equal heights. For multi-level constructs, verify that the Screw Heads replicate the curvature of the rod

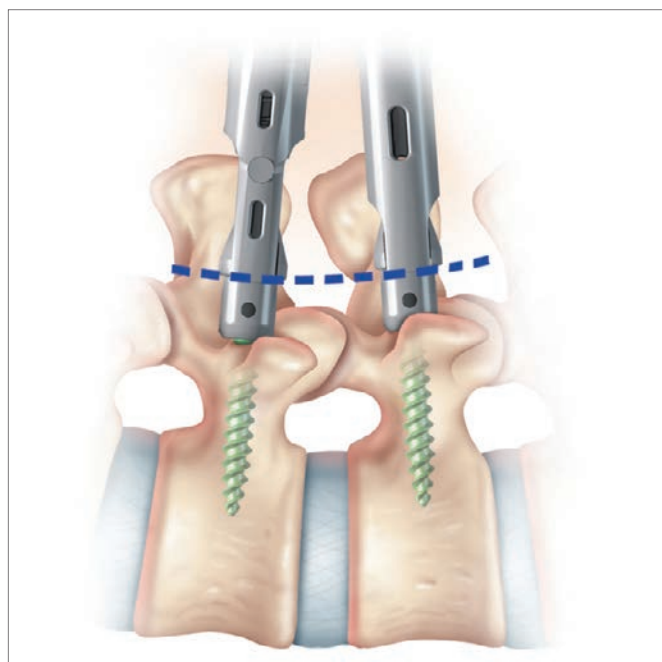

Remove the Reinforcement Posts for the Open Extensions. Repeat Screw placement procedures at each surgical level

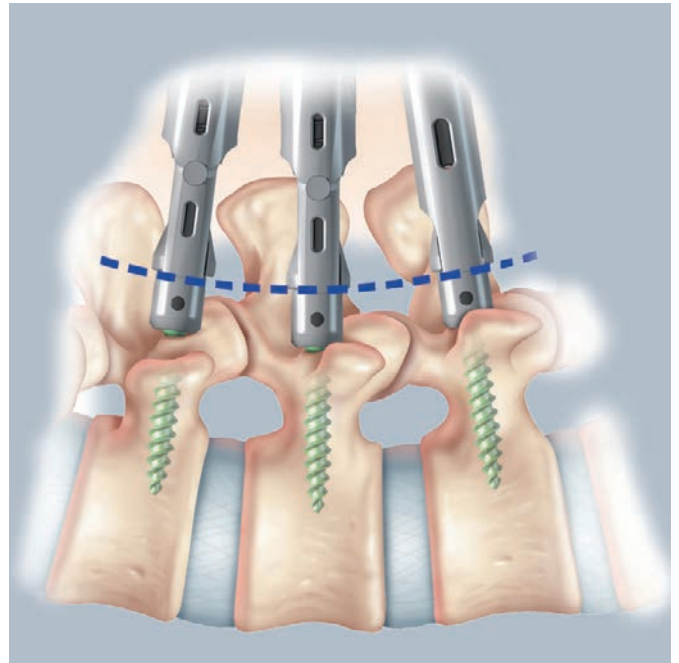

ROD MEASURING

- Insert one arm of the Rod Measuring Caliper into each of the outermost extensions until each leg is fully seated in the Screw Head. Check placement via fluoroscopy. Additionally, placement can be verified by ensuring that the circumferential lines on the shafts of the Rod Measuring Caliper align with the top of each extension
- Once correctly positioned, read the rod length measurement indicated at the top of the caliper

Note: The Rod Measuring Caliper can be used to measure segments greater than 140 mm by adding two or more measurements together



Attach Rod to Appropriate Rod Holder

- Select the appropriate Rod Holder based on the length of the rod that will be inserted
 - Conventional Rod Holder for rod lengths of 100 mm or less
 - Advanced Rod Holder for rod lengths greater than 100 mm
- Depending on the curvature of the spine at the operated levels, select the pre-lordosed or pre-kyphosed rod that best fits the measured rod length. Alternatively, straight rods can be contoured to the patient's anatomy.



Angled and Advanced Rod Holders

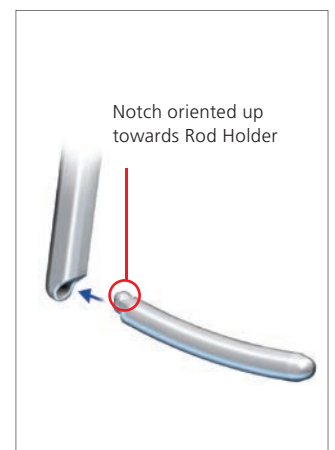

Rod placement into Rod Holder

Note: The appropriate sagittal plane contour can be estimated by placing the rod atop the Screw Extensions or directly on the patient's skin adjacent to the Screw Extensions

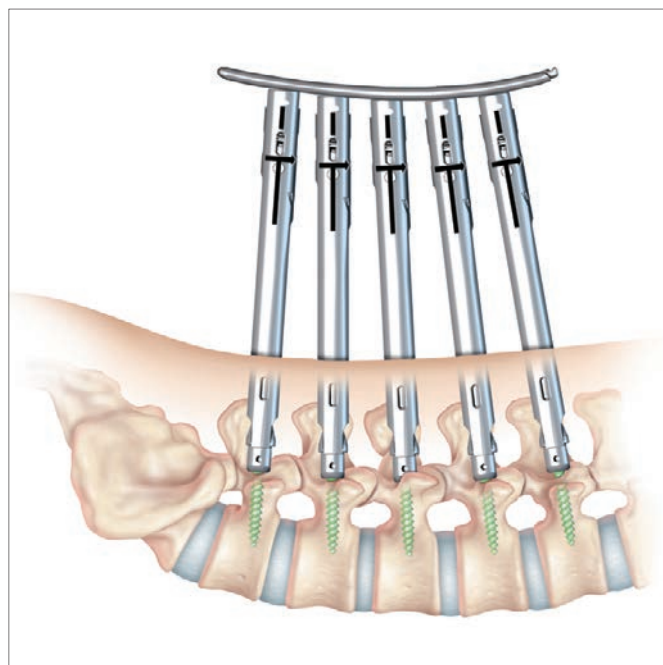

- After choosing the appropriate length rod, contour and corresponding Rod Holder, insert the connection end of the rod into the pocket of the Rod Holder ensuring that the notch on the connection end of the rod is facing up towards the handle of the Rod Holder
- Connect the Torque Limiting Handle to the X-15 Rod Tightening shaft. Use this instrument to tighten the Rod Locking Bolt of the Rod Holder until the Torque Limiting handle "clicks." Verify that the rod is securely attached to the Rod Holder

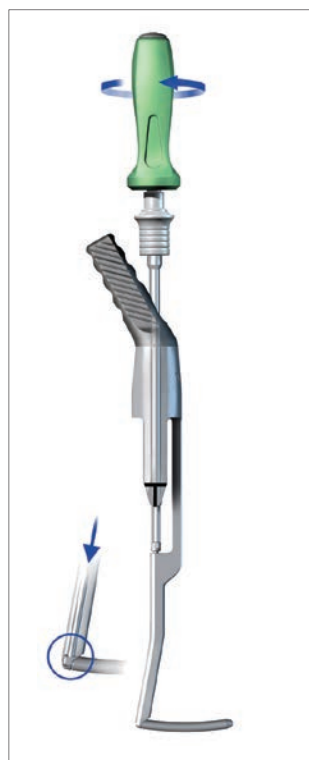

CONVENTIONAL ROD INSERTION

- Use both Closed and Open Extensions in conjunction with the Conventional Rod Holder
- Align the slots of the Screw Extensions and rotate the Closed Screw Extension so that the arrow points towards the Open Screw Extension. Position the Conventional Rod Holder handle to be parallel to the skin surface with the lead tip of the rod facing downward. Insert the Rod Holder Assembly through the Open Screw Extension(s), and advance the Rod Holder into the slot of the Closed Screw Extension. The entire rod should be contained within the Closed Screw Extension
- Use the Rod Holder to align the Screw Extensions until they are parallel with one another
- If the Screw Extensions are crossed, the surgeon should attempt to uncross them. If it is not possible, use the Rod Holder to bypass the Open Screw Extension and guide the rod into the slot of the Closed Screw Extension
- Advance the distal end of the rod towards the screw, down the Closed Screw Extension until it touches the top of the Screw Head or it is as deep as the tissue will allow. It is necessary for the distal end of the rod to be below the fascia before proceeding

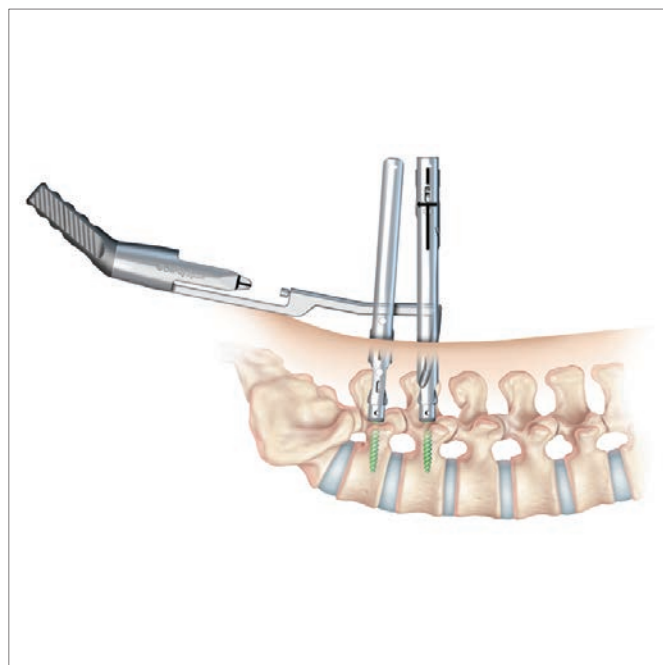

- Rotate the Rod Holder Handle Upwards 90° until it nests with the proximal end of the Closed Extension. This action will guide the rod into the distal slot of the Open Screw Extension(s). To confirm the rod is seated inside the Closed Screw Extension, align the vertical and horizontal markers on the Rod Holder with the arrow and vertical line on the Closed Screw Extension

Note: To verify the rod has passed through the Open Screw Extension(s), twist the Open Extension about its axis. If the Extension does not rotate, then the rod has been properly passed. If the Extension is able to rotate, the rod is not contained within the Extension and rod placement should be re-attempted. Fluoroscopy should be used to verify adequate rod overhang at each end of the construct

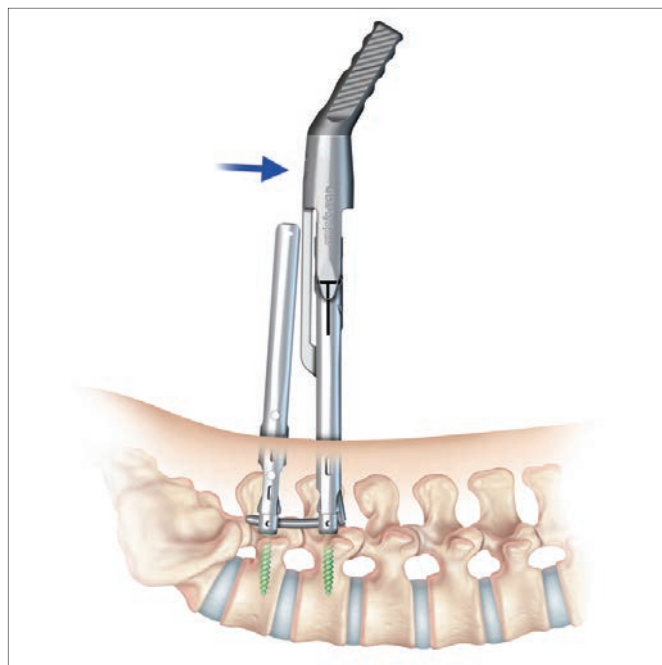
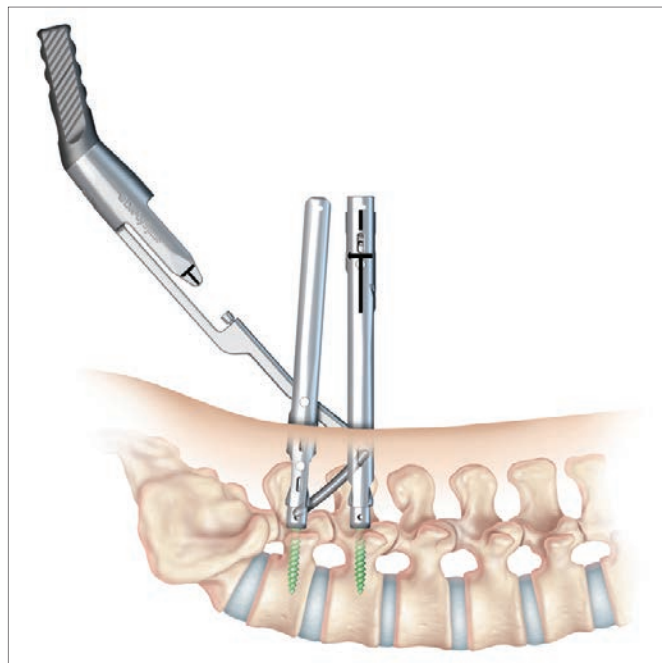

ADVANCED ROD INSERTION

Use Closed Extensions and/or X-Tab Screws with the Advanced Rod Holder

Assemble and insert Closed Extensions or screws over guidewires. Align the openings of the Screw Extensions as much as possible. Rotate the cephalad-most Screw Extensions so the arrow points in the cephalad direction

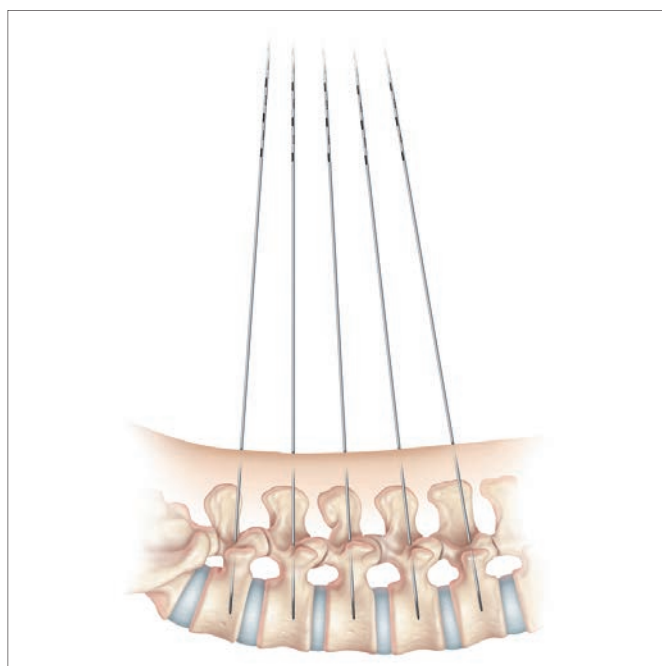
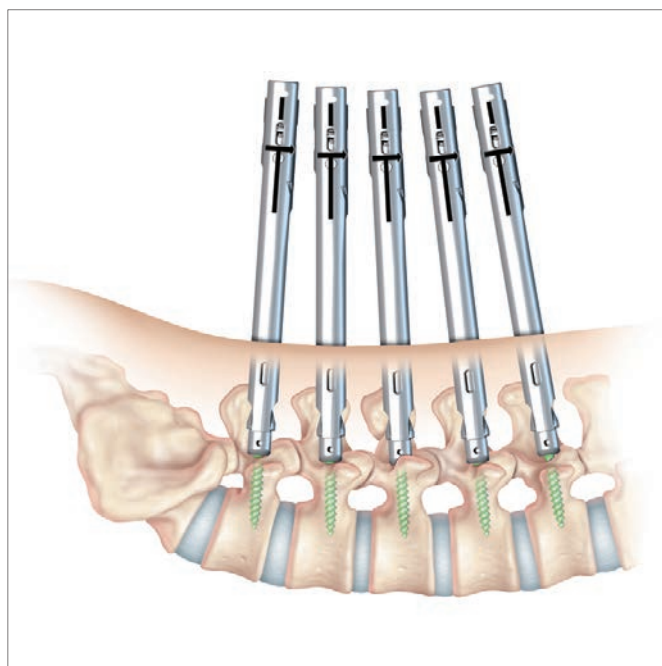

- Position the Rod Holder Handle to be as parallel as possible to the skin surface, with the rod parallel to the axis of the slots of the Extension (perpendicular to the skin). Insert the rod into the cephalad slot of the Extension. The tip of the rod should be contained within the Closed Screw Extension. Advance the distal end of the rod straight down towards the screw until it touches the top of the Screw Head or it is as deep as the tissue will allow. It is necessary for the distal end of the Rod to be below the fascia before proceeding
- Rotate the handle of the Rod Holder toward the cephalad direction approximately 45°. This action will guide the tip of the rod towards each successive Extension

Note: Depending on the curvature of the spine, the Rod Holder may need to be rotated along an arc that parallels that curvature of the spine

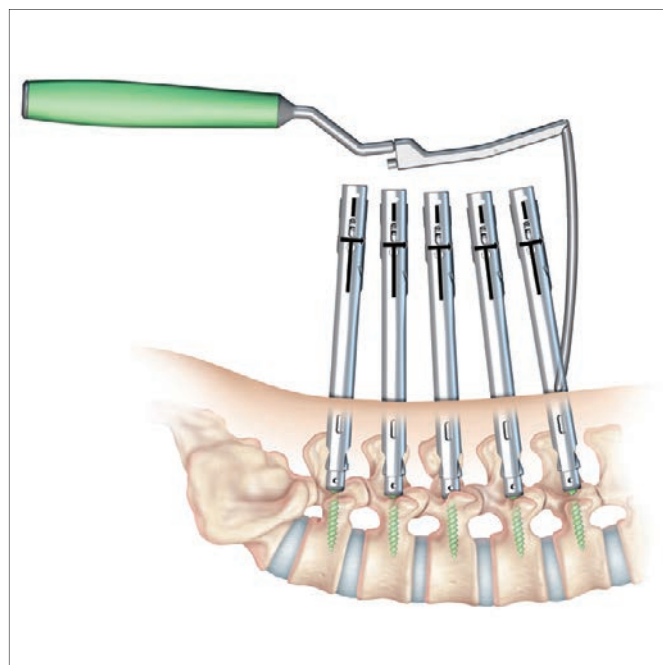

Continue to advance the rod subfascially into the adjacent Extensions by moving the Rod Holder towards each subsequent Extension in a linear fashion. Verify that the rod has passed through an Extension by attempting to rotate the Extension about its axis. If you are unable to rotate the Extension, the rod has properly passed within the Extension. This process should be conducted as the rod is passed at each level. The rod passage should end inside the most caudal Extension

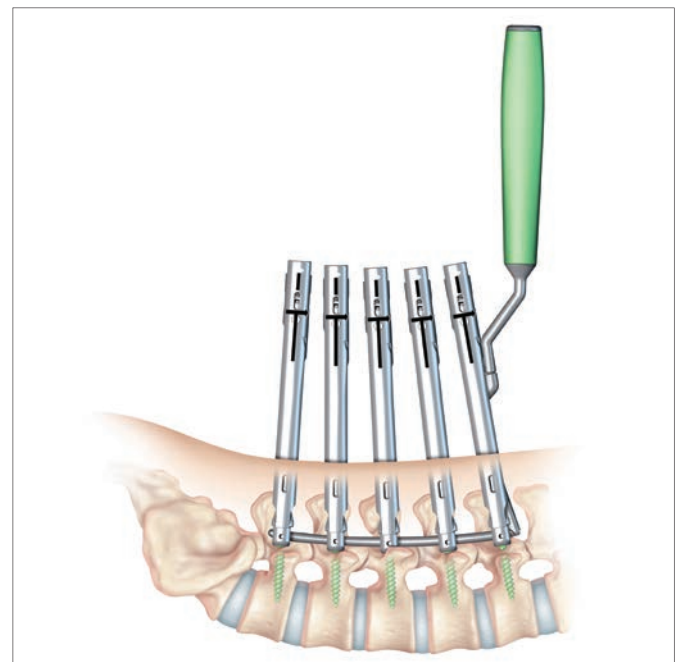
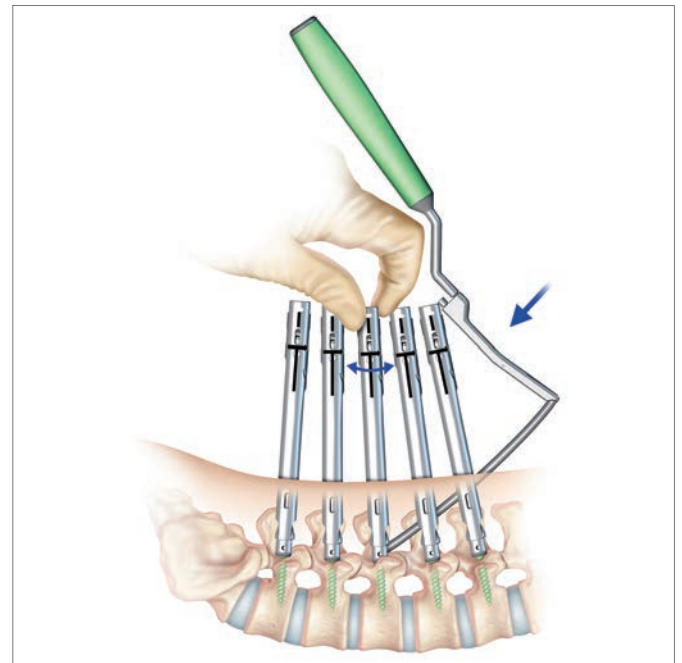

Note: To help align multiple Extensions, guide the Screw Extension Alignment guide on the outside of all Extensions by introducing from the caudal direction

- When necessary, the rod can be “directed” by manipulating the Extensions while adjusting the rod position and orientation with the Rod Holder. Fluoroscopy can provide additional guidance during rod insertion
- Engage the distal half of the Advanced Rod Holder into the outer slot of the cephalad-most Closed Screw Extension. Fluoroscopy can be used to confirm rod placement and appropriate overhang at the outermost Extensions. Once in final position, the rod should be locked down with Set Screws. The Rod Holder will need to be removed prior to placing a Set Screw at that location

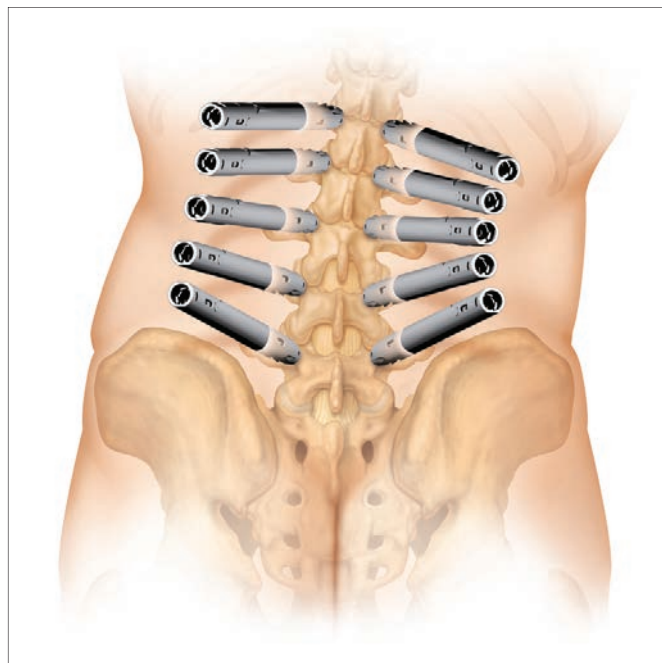

SET SCREW INSERTION

- Load a Set Screw from the caddy onto the X25 Inserter. Twist the proximal knob on the handle until the Set Screw is secured. Do not over tighten the locking feature. Doing so may damage the instrument. Guide the X25 Inserter into any Screw Extension not occupied by the Rod Holder and loosely tighten the Set Screw to capture the rod. The Screw Head should remain mobile to enable repositioning of the Screw Extension, which may assist during subsequent steps
- If the proximal depth marker on the shaft of the X25 Inserter is the top of the Screw Extension, then the Set Screw is seated within the Screw Head. To verify proper engagement, pull up slightly on the X25 Inserter to ensure the Set Screw is captured in the Screw Head before disengaging. Remove the X25 Inserter by turning the proximal knob counter-clockwise and withdrawing the instrument

Note: If difficulty is encountered introducing the Set Screw into the Screw Head, the rod may lie above the Screw Head. Use Fluoroscopy to verify rod placement. If rod approximation is required, utilize the Rod Approximator to deliver the Set Screw using the procedure described in the Rod Approximator section

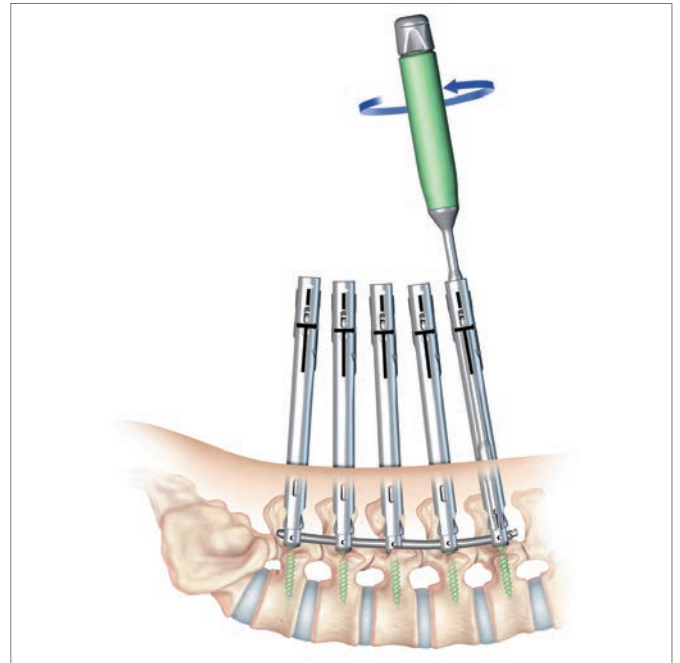

ROD APPROXIMATION USING THE VIPER 2 ROD APPROXIMATOR

Attach the cap of the Rod Approximator to the Screw Extension. Align the vertical lines on the cap with the corresponding lines on the proximal end of the Extension. Push the cap of the Rod Approximator onto the Screw Extension until the Approximator snaps into place and the buttons engage the slots. To verify secure attachment, lightly pull on the cap to check attachment to Extension.

Note: When using the Rod Approximator with the Open Extension, insert the Open Screw Reinforcement Post before use



Load a Set Screw on the Self-Retaining Approximating Set Screw Driver by pushing down on a Set Screw until it is fully seated on the flange of the Self-Retaining Set Screw Driver

Note: Ensure that the tip of the driver is protruding past the Set Screw by approximately 1 mm



Insert the loaded Self-Retaining Set Screw Driver through the Rod Approximator cap and into the Extension. The Driver tip will contact the Rod

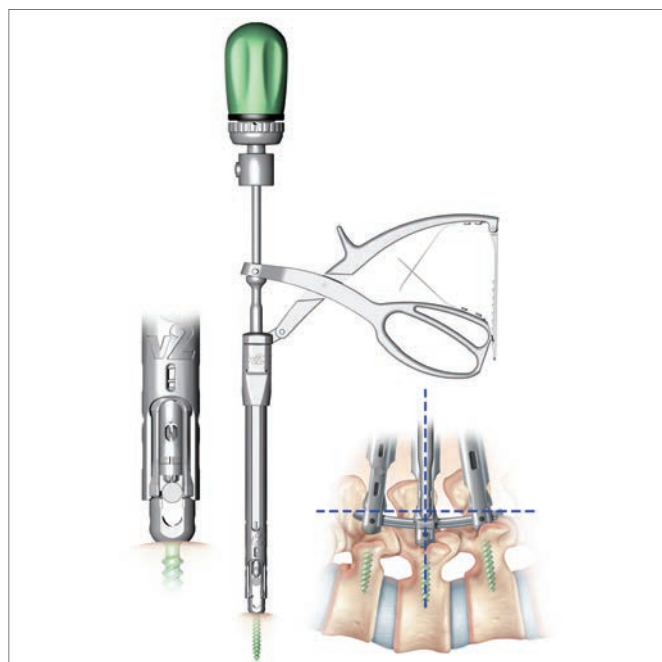

Rotate the Rod Approximator handle up to engage flange on the Self-Retaining Approximating Set Screw Driver. Squeeze the Approximator handle to introduce the rod into the Screw Head. Continue to squeeze the handle until the rod is driven into the Screw Head and the instrument reaches the final locked position

Note: Incremental reduction can be accomplished by utilizing anyone of the multiple teeth on the locking rack

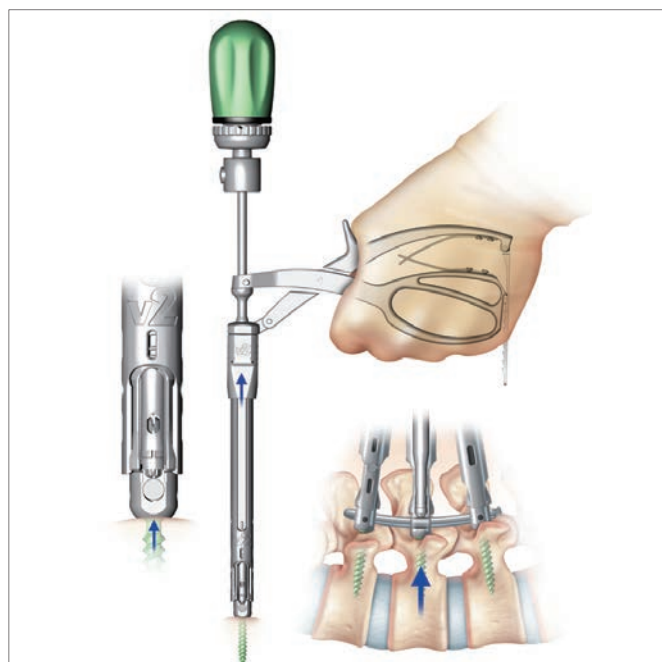

- The amount of approximation can be measured by using the marker bands on the proximal end of the Self-Retaining Set Screw Driver. The distance between each band is 5 mm. Proper Rod placement can be verified by ensuring the final marker band is aligned with the top of the Cap of the Pistol Grip. Only after reaching the final locked position should the Set Screw Driver handle be rotated to engage the Set Screw threads
- To remove the Rod Approximator, depress both buttons on the cap simultaneously and pull up

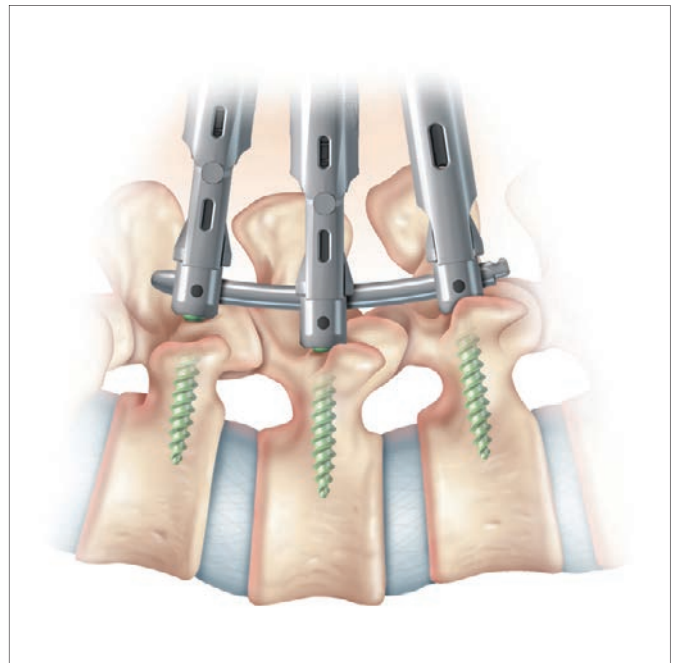

ROD APPROXIMATION WITH THE X-TAB REDUCTION SCREWS

- Load a Set Screw from the caddy onto the X25 Inserter. Twist the proximal knob on the handle until the Set Screw is secured. Guide the first Set Screw into the center of the Extended Reduction tab. The Set Screw should engage the reduction thread approximately 7 mm above the top of the Screw Head. Rotate the handle of the driver clockwise to engage the reduction threads and drive the rod into the Screw Head

Note: The X-Tab Screws will provide approximately 7 mm of rod reduction. If greater correction is needed, Standard VIPER Screws connected to VIPER 2 Screw Extensions should be used and rod approximation should be accomplished with the Rod Approximator instrument

- Continue to rotate the Set Screw Driver until the rod is fully seated in the Screw Head. The proximal depth marker on the X25 Inserter should be aligned with the top of the Reduction Tabs when the Set Screw is seated within the Screw Head. Remove the X25 Inserter by rotating the proximal knob counter-clockwise to loosen from the Set Screw



COMPRESSION/DISTRACTION

- Assemble the Compression/Distract Adjustable Fulcrum to the sleeve by aligning the slots on the Adjustable Fulcrum with the opposite geometry on the track of the sleeve. Simultaneously depress both buttons on the Adjustable Fulcrum and slide it into the track of the Compression/Distract Sleeve
- Final tighten the Set Screw at the end of the construct. It is imperative that the connection features on the ends of the rod are located outside of the Screw Head to ensure that the appropriate screw/rod interface is established. Next, ensure that the Set Screw at the adjacent location is loosely affixed (not tightened)
- Slide the Compression/Distract Sleeve over the Extension that has not yet been final tightened. The top of the sleeve will interface with the flats on the Screw Extension or Reinforcement Post. Adjust the Fulcrum so that it is positioned at the top of the Compression/Distract Sleeve. Advance the X25 Final Tightener down the Screw Extension that has not been final tightened to engage the Set Screw

Note: If compressing or distracting with an Open Extension, insert the Open Screw Extension Reinforcement Post. If compressing or distracting with an X-Tab Reduction Screw, insert the X-Tab Sleeve over the tabs to provide an appropriate fit with the Compression/Distract Sleeve and to prevent premature tab detachment

- Introduce the Compression Forceps as low as possible below the Fulcrum and compress. Once in the desired position, tighten the Set Screw
- Distraction may also be applied by moving the Adjustable Fulcrum as low as possible (as close as possible to the skin) and advancing the X25 Final Tightener down the Screw Extension to engage the Set Screw. Introduce the Compression Forceps as high as possible above the Fulcrum and compress. Once in the desired position, tighten the Set Screw

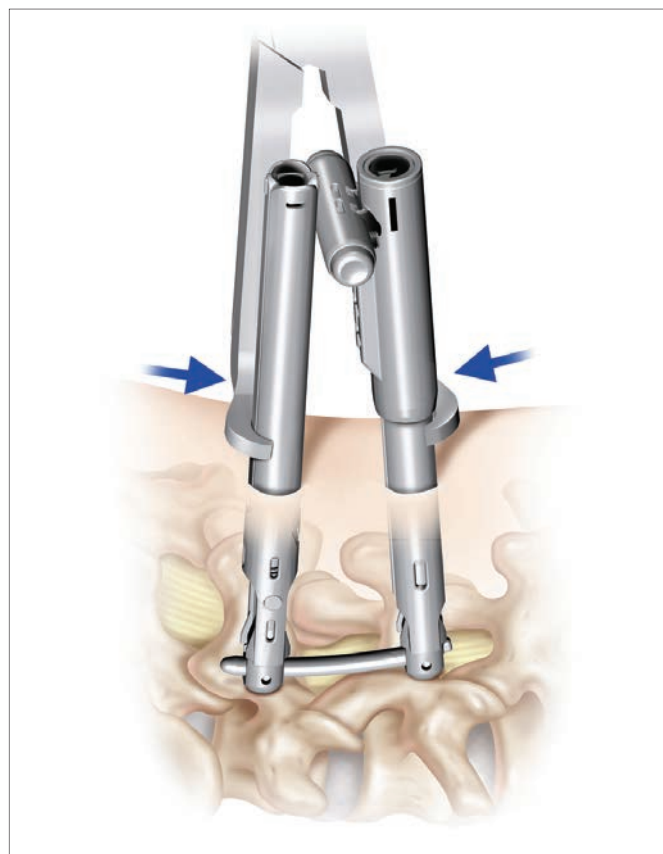

ROD HOLDER REMOVAL

- Before removal of the Rod Holder, it should be confirmed fluoroscopically that the proximal end of the rod is fully seated inside the Screw Head with approximately 5 mm overhang from each of the Screw Heads
- Insert the X15 Rod Tightener shaft inside the Rod Holder to engage the Rod Holder bolt
- Turn the X15 Rod Tightener counter-clockwise to disengage the rod from the Rod Holder
- Remove the X15 Rod Tightener. Rotate the Rod Holder forward slightly while pulling the holder away from the patient to remove it

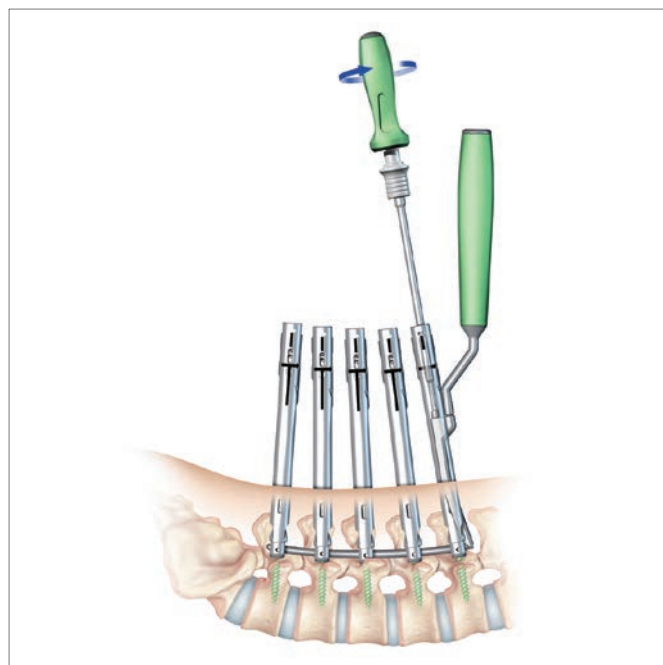

FINAL TIGHTENING/COUNTER-TORQUE

- Using fluoroscopy, verify that the rod overhangs the outermost Screws by approximately 5 mm. (The rod connection features should be fully outside the Screw head)
- To perform final tightening, place the Counter-Torque/Rod Stabilizer around one of the Extensions. Ensure that the notches of the stabilizer straddle the Rod. Assemble the X25 Final Tightener to the Final Tightening Torque Handle, pass through the Screw Extension, and engage the Set Screw

Note: If Final tightening on an X-Tab Screw, ensure that the smaller X-Tab Counter-Torque stabilizer is used

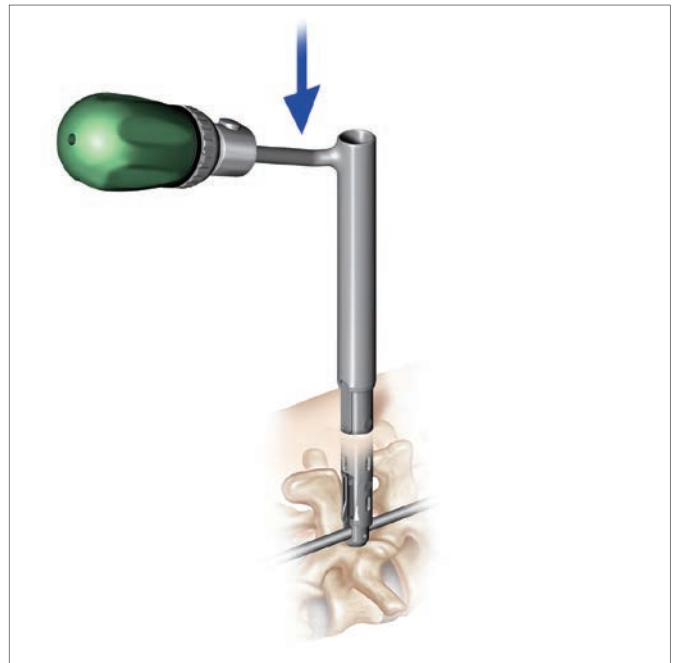

Rotate the Torque Wrench Handle clockwise, while applying Counter-Torque via the Counter-Torque/Rod Stabilizer, until the torque handle clicks. Repeat for additional Set Screws



For patients with good bone quality, the Counter-Torque Wrench can alternatively be used to provide Counter-Torque

- Slide the Counter-Torque Wrench over the Extension and engage the flats. When used on an Open Extension, the Open Screw Extension reinforcement post should also be used. Follow the final tightening procedure described above

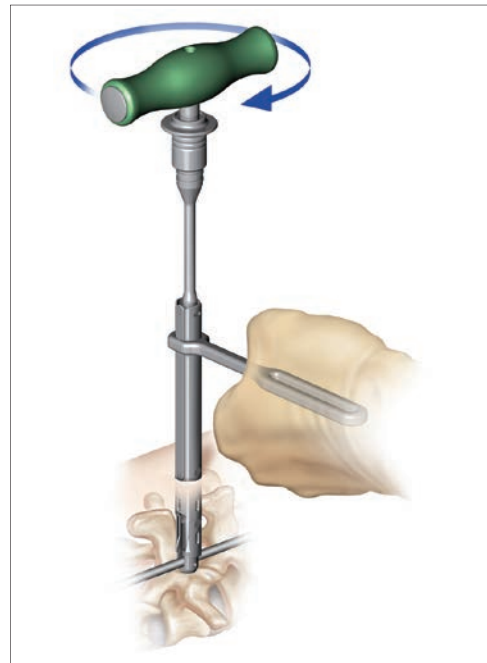

SCREW EXTENSION REMOVAL

Assemble the Castle Nut Driver for removal by inserting the Inner Removal Sleeve into the top of the Castle Nut Driver until it snaps and locks into place. Insert the Inner Removal Shaft into the Inner Removal Sleeve until the proximal head of the shaft “snaps” into the first groove of the Inner Removal Sleeve. This is the “unlocked” position and there should be a gap between the plastic handle and the metal proximal cap

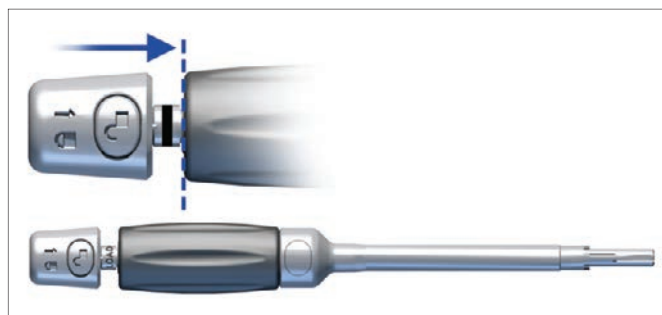

- Insert the Castle Nut Driver into the Screw Extension until the Driver engages the Castle Nut of the Extension. To verify engagement, the top of the Extension should be aligned with the circumferential marker band on the Castle Nut Driver Assembly
- Once the Castle Nut is engaged, push down on the head of the Inner Removal Shaft, until it engages the second groove on the Inner Removal Sleeve; this is the Locked position. The Castle Nut Driver and Screw Extension are now linked together

Note: The marker band is located on the distal end of the Castle Nut Driver when being used to remove a Closed Screw Extension. The marker band is located on the proximal end of the Castle Nut Driver, just distal to the handle, when being used to remove an Open Screw Extension

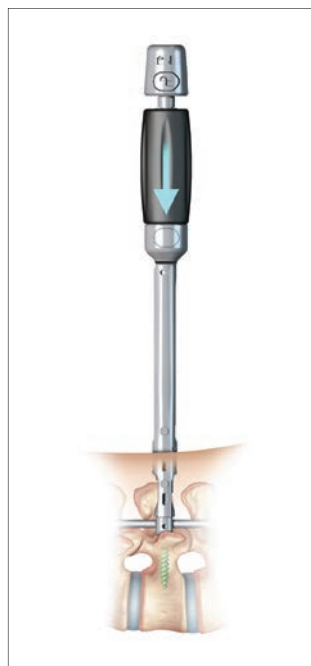

Rotate the Castle Nut Driver four (4) full turns. This action will loosen the Extension from the Screw Head. If the Screw Extension does not automatically disconnect from the screw, rotate the Screw Extension 90° and apply slight upward pressure

Note: The Extension will not require significant force to be removed. If there is difficulty removing the Extension, verify that the Castle Nut Driver is coupled to the Extension then continue to rotate the driver while applying gentle upward force

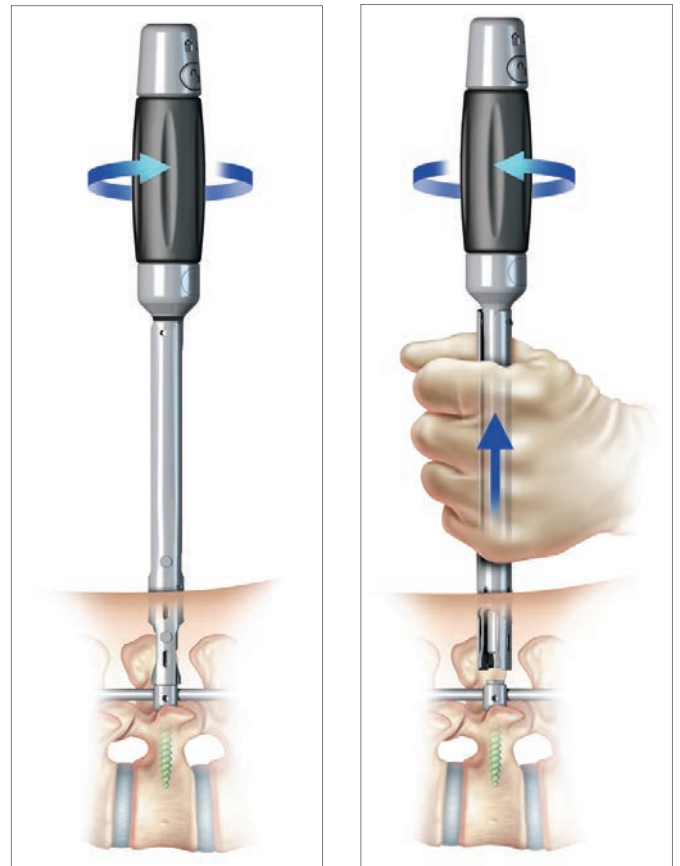

To remove the Extension from the Castle Nut Driver push the "lock/unlock" button and separate the Extension from the Castle Nut Driver. The Castle Nut Driver should now be in the unlocked position

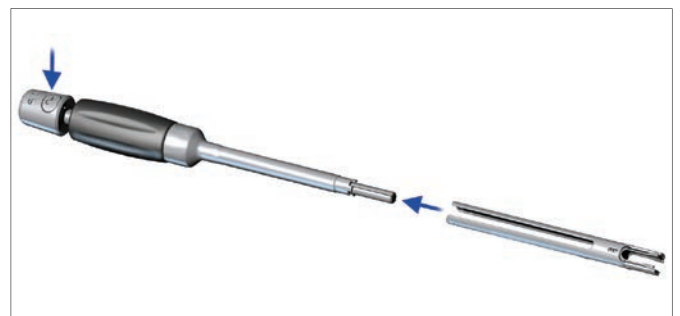

X-TAB REMOVAL

- Insert the Tab Removal tool into the center of the two tabs ensuring that the large cylinder portion is inside the screw tabs (centered over the Screw Head) while the thin tang portion is fully capturing the outside of the tab. Advance the Tab Remover until it reaches the Screw Head and can no longer be advanced
- Rock the Tab Remover outward (away from the center of the screw) approximately 15° until the tab breaks away from the Screw Head

Note: This motion may need to be repeated a few times to ensure proper breakage

- The tab should be retained inside the Tab Remover. Remove the tab by depressing the button at the top of the Tab Remover handle. Ensure that the tab is removed prior to repeating this technique on the next tab



PRODUCT CATALOG

INSTRUMENTS

Item #	Description
2867-15-100	VIPER 2 Pedicle Prep Cannula
2867-15-150	VIPER 2 Tap Sheath
2867-15-210	VIPER 2 Awl, Cannulated
2867-15-300	VIPER 2 Ratcheting Modular Straight Handle, Cannulated
2867-15-350	VIPER 2 Ratcheting Modular T-Handle, Cannulated
2867-15-450	Cannulated Tap Dual Lead, 4.35 mm
2867-15-451	Cannulated Tap Single Lead, 4.35 mm
2867-15-500	VIPER 2 5 mm Self Drilling Tap, Cannulated and Dual Lead
2867-15-600	VIPER 2 6 mm Self Drilling Tap, Cannulated and Dual Lead
2867-15-700	VIPER 2 7 mm Self Drilling Tap, Cannulated and Dual Lead
2867-15-800	VIPER 2 8 mm Self Drilling Tap, Cannulated and Dual Lead
2867-15-900	VIPER 2 9 mm Self Drilling Tap, Cannulated and Dual Lead
2867-15-111	Pedicle Prep Cannula, Large Diameter
2867-10-200	VIPER Ball Tip Feeler
2867-20-000	Polyaxial Screw Driver Shaft, Cannulated
2867-30-150	Rod Pusher Guide
2867-25-010	VIPER 2 X15 Hexlobe Rod Tightener
2867-25-020	VIPER 2 T20 Hexlobe Driver Shaft
2867-25-050	VIPER 2 Rod Tightener Handle, Torque Limiting
2867-25-200	VIPER 2 Screw Extension, Closed
2867-25-250	VIPER 2 Neuro Stimulation Sleeve
2867-25-300	VIPER 2 Screw Extension, Open
2867-25-350	VIPER 2 Open Screw Extension Reinforcement Post
2867-25-400	VIPER 2 Castle Nut Tightener, Torque Limiting

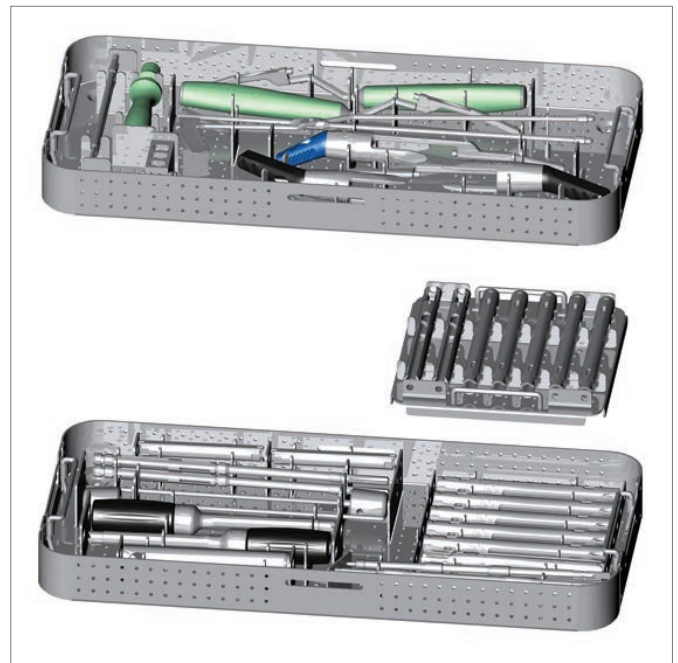

2867-25-410	VIPER 2 Castle Nut Tightener, Removal Shaft
2867-25-420	VIPER 2 Castle Nut Tightener, Removal Sleeve
2867-35-050	VIPER 2 Rod Gauge
2867-35-100	VIPER 2 Rod Holder, Angled
2867-35-110	VIPER 2 Rod Holder, Bolt
2867-35-150	VIPER 2 Extension Alignment Guide, Open
2867-35-200	VIPER 2 Rod Holder, Advanced

Note: VIPER 2 taps are undersized to the corresponding screw size by 0.5 mm to ensure optimal screw purchase. Hence, a 6 mm tap is actually 5.5 mm in diameter. Undersizing the tap may result in difficulty starting the screw. The corresponding tap size should be used for the chosen screw diameter.

Item #	Description
2770-30-110	Rod Holder, Kerrison
2770-30-000	French Rod Bender
2867-35-300	VIPER 2 Rod Approximator, Pistol Grip
2867-35-350	VIPER 2 X25 Approximating Set Screw Inserter, Pistol Grip
2867-35-400	VIPER 2 X25 Set Screw Inserter, Self-Retaining
2867-35-600	VIPER 2 Compression Assembly
2731-22-201	PLIF SG TBar
2867-40-000	Compressor
2797-12-550	Intermediate Tightener X25
2867-45-100	VIPER 2 Rod Stabilizer/Anti-Torque Sleeve
2867-45-150	VIPER 2 Anti-Torque Wrench
2867-45-500	VIPER 2 Final Tightener Handle, Torque Limiting
2867-45-550	VIPER 2 Final Tightener Shaft

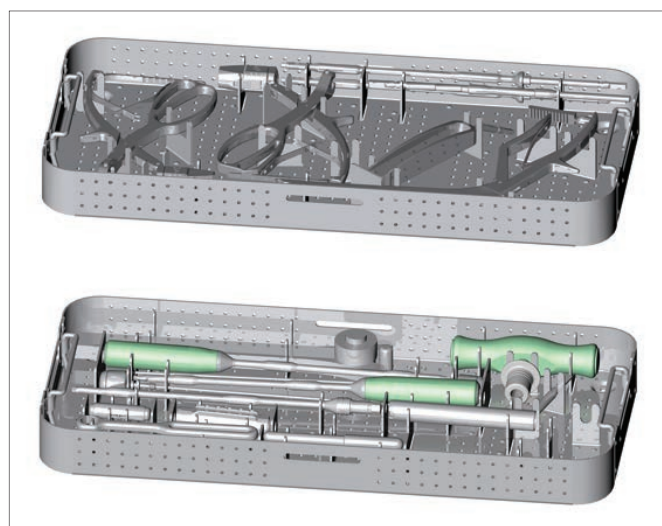

CASES AND TRAYS

Item #	Description
2867-05-000	VIPER 2 Instrument Case
2867-05-010	VIPER 2 Instrument Case 1, Tray 1
2867-05-020	VIPER 2 Instrument Case 1, Tray 2
2867-05-030	VIPER 2 Instrument Case 2, Tray 1
2867-05-040	VIPER 2 Instrument Case Lid
2867-05-050	VIPER 2 Instrument Case 2, Tray 2
2867-05-060	VIPER 2 Instrument Case 3, Tray 1
2867-05-070	VIPER 2 Instrument Case 3, Tray 2
2867-05-080	VIPER 2 Implant Tray
2867-05-085	VIPER 2 Implant Tray Lid
2867-05-250	VIPER 2 Rod Caddy
2867-05-350	VIPER 2 Loading Block
2867-05-570	VIPER 2 5 mm x 7 mm Screw Caddy
2867-05-600	VIPER 2 6 mm Screw Caddy

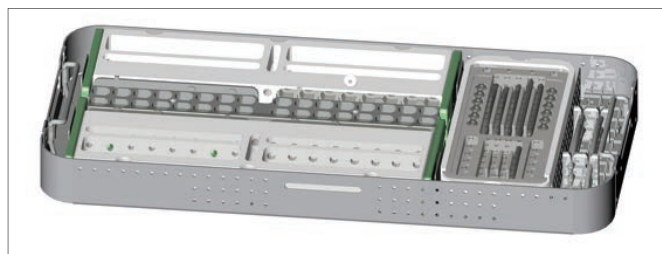

RODS

VIPER 2 Kyphosed Rod

Item #	Description
1867-87-035	VIPER 2 Kyphosed Rod-35 mm, Ti
1867-87-040	VIPER 2 Kyphosed Rod-40 mm, Ti
1867-87-050	VIPER 2 Kyphosed Rod-50 mm, Ti
1867-87-060	VIPER 2 Kyphosed Rod-60 mm, Ti
1867-87-070	VIPER 2 Kyphosed Rod-70 mm, Ti
1867-87-080	VIPER 2 Kyphosed Rod-80 mm, Ti
1867-87-090	VIPER 2 Kyphosed Rod-90 mm, Ti
1867-87-100	VIPER 2 Kyphosed Rod-100 mm, Ti
1867-87-110	VIPER 2 Kyphosed Rod-110 mm, Ti
1867-87-120	VIPER 2 Kyphosed Rod-120 mm, Ti
1867-87-150	VIPER 2 Kyphosed Rod-150 mm, Ti
1867-87-200	VIPER 2 Kyphosed Rod-200 mm, Ti
1867-87-300	VIPER 2 Kyphosed Rod-300 mm, Ti

VIPER 2 Lordosed Rod

Item #	Description
1867-88-030	VIPER 2 Lordosed Rod-30 mm, Ti
1867-88-035	VIPER 2 Lordosed Rod-35 mm, Ti
1867-88-040	VIPER 2 Lordosed Rod-40 mm, Ti
1867-88-045	VIPER 2 Lordosed Rod-45 mm, Ti
1867-88-050	VIPER 2 Lordosed Rod-50 mm, Ti
1867-88-055	VIPER 2 Lordosed Rod-55 mm, Ti
1867-88-060	VIPER 2 Lordosed Rod-60 mm, Ti
1867-88-065	VIPER 2 Lordosed Rod-65 mm, Ti
1867-88-070	VIPER 2 Lordosed Rod-70 mm, Ti
1867-88-075	VIPER 2 Lordosed Rod-75 mm, Ti
1867-88-080	VIPER 2 Lordosed Rod-80 mm, Ti
1867-88-085	VIPER 2 Lordosed Rod-85 mm, Ti
1867-88-090	VIPER 2 Lordosed Rod-90 mm, Ti
1867-88-100	VIPER 2 Lordosed Rod-100 mm, Ti
1867-88-110	VIPER 2 Lordosed Rod-110 mm, Ti
1867-88-120	VIPER 2 Lordosed Rod-120 mm, Ti
1867-88-150	VIPER 2 Lordosed Rod-150 mm, Ti
1867-88-200	VIPER 2 Lordosed Rod-200 mm, Ti

VIPER 2 Straight Rod

Item #	Description
1867-89-035	VIPER 2 Straight Rod-35 mm, Ti
1867-89-040	VIPER 2 Straight Rod-40 mm, Ti
1867-89-050	VIPER 2 Straight Rod-50 mm, Ti
1867-89-060	VIPER 2 Straight Rod-60 mm, Ti
1867-89-070	VIPER 2 Straight Rod-70 mm, Ti
1867-89-080	VIPER 2 Straight Rod-80 mm, Ti
1867-89-090	VIPER 2 Straight Rod-90 mm, Ti
1867-89-100	VIPER 2 Straight Rod-100 mm, Ti
1867-89-110	VIPER 2 Straight Rod-110 mm, Ti
1867-89-120	VIPER 2 Straight Rod-120 mm, Ti
1867-89-150	VIPER 2 Straight Rod-150 mm, Ti
1867-89-200	VIPER 2 Straight Rod-200 mm, Ti
1867-89-300	VIPER 2 Straight Rod-300 mm, Ti
1867-89-400	VIPER 2 Straight Rod-400 mm, Ti
1867-89-600	VIPER 2 Straight Rod-600 mm, Ti

Cobalt Chromium Alloy Rods

Item #	Description
1967-88-120	VIPER 2 Lordosed Rod-120 mm, CoCr
1967-89-120	VIPER 2 Straight Rod-120 mm, CoCr
1967-89-200	VIPER 2 Straight Rod-200 mm, CoCr
1967-89-300	VIPER 2 Straight Rod-300 mm, CoCr
1967-89-400	VIPER 2 Straight Rod-400 mm, CoCr
1967-89-480	VIPER 2 Straight Rod-480 mm, CoCr
1967-89-600	VIPER 2 Straight Rod-600 mm, CoCr

SCREWS

Single-inner Set Screw

Item #	Description
1867-15-000	Single-Inner Set Screw, Ti

MIS Cannulated Polyaxial Screw

Item #	Description
1867-15-430	MIS Cannulated Polyaxial Screw, 4.35 mm x 30 mm, Ti
1867-15-435	MIS Cannulated Polyaxial Screw, 4.35 mm x 35 mm, Ti
1867-15-440	MIS Cannulated Polyaxial Screw, 4.35 mm x 40 mm, Ti
1867-15-445	MIS Cannulated Polyaxial Screw, 4.35 mm x 45 mm, Ti
1867-15-450	MIS Cannulated Polyaxial Screw, 4.35 mm x 50 mm, Ti
1867-15-455	MIS Cannulated Polyaxial Screw, 4.35 mm x 55 mm, Ti
1867-15-530	MIS Cannulated Polyaxial Screw, 5 mm x 30 mm, Ti
1867-15-535	MIS Cannulated Polyaxial Screw, 5 mm x 35 mm, Ti
1867-15-540	MIS Cannulated Polyaxial Screw, 5 mm x 40 mm, Ti
1867-15-545	MIS Cannulated Polyaxial Screw, 5 mm x 45 mm, Ti
1867-15-550	MIS Cannulated Polyaxial Screw, 5 mm x 50 mm, Ti
1867-15-630	MIS Cannulated Polyaxial Screw, 6 mm x 30 mm, Ti
1867-15-635	MIS Cannulated Polyaxial Screw, 6 mm x 35 mm, Ti
1867-15-640	MIS Cannulated Polyaxial Screw, 6 mm x 40 mm, Ti
1867-15-645	MIS Cannulated Polyaxial Screw, 6 mm x 45 mm, Ti
1867-15-650	MIS Cannulated Polyaxial Screw, 6 mm x 50 mm, Ti
1867-15-655	MIS Cannulated Polyaxial Screw, 6 mm x 55 mm, Ti

1867-15-730	MIS Cannulated Polyaxial Screw, 7 mm x 30 mm, Ti
1867-15-735	MIS Cannulated Polyaxial Screw, 7 mm x 35 mm, Ti
1867-15-740	MIS Cannulated Polyaxial Screw, 7 mm x 40 mm, Ti
1867-15-745	MIS Cannulated Polyaxial Screw, 7 mm x 45 mm, Ti
1867-15-750	MIS Cannulated Polyaxial Screw, 7 mm x 50 mm, Ti
1867-15-755	MIS Cannulated Polyaxial Screw, 7 mm x 55 mm, Ti
1867-15-030	MIS Cannulated Polyaxial Screw, 7.5 mm x 30 mm, Ti
1867-15-035	MIS Cannulated Polyaxial Screw, 7.5 mm x 35 mm, Ti
1867-15-040	MIS Cannulated Polyaxial Screw, 7.5 mm x 40 mm, Ti
1867-15-045	MIS Cannulated Polyaxial Screw, 7.5 mm x 45 mm, Ti
1867-15-050	MIS Cannulated Polyaxial Screw, 7.5 mm x 50 mm, Ti
1867-15-055	MIS Cannulated Polyaxial Screw, 7.5 mm x 55 mm, Ti
1867-15-830	MIS Cannulated Polyaxial Screw, 8 mm x 30 mm, Ti
1867-15-835	MIS Cannulated Polyaxial Screw, 8 mm x 35 mm, Ti
1867-15-840	MIS Cannulated Polyaxial Screw, 8 mm x 40 mm, Ti
1867-15-845	MIS Cannulated Polyaxial Screw, 8 mm x 45 mm, Ti
1867-15-850	MIS Cannulated Polyaxial Screw, 8 mm x 50 mm, Ti
1867-15-855	MIS Cannulated Polyaxial Screw, 8 mm x 55 mm, Ti
1867-15-930	MIS Cannulated Polyaxial Screw, 9 mm x 30 mm, Ti
1867-15-935	MIS Cannulated Polyaxial Screw, 9 mm x 35 mm, Ti
1867-15-940	MIS Cannulated Polyaxial Screw, 9 mm x 40 mm, Ti

1867-15-945	MIS Cannulated Polyaxial Screw, 9 mm × 45 mm, Ti
1867-15-950	MIS Cannulated Polyaxial Screw, 9 mm × 50 mm, Ti
1867-15-955	MIS Cannulated Polyaxial Screw, 9 mm × 55 mm, Ti

INSTRUMENTS, CASES AND TRAYS

X-Tab

Item #	Description
2867-60-350	X-Tab Insertion Sleeve
2867-60-100	X-Tab Anti-torque
2867-60-010	Polyaxial Driver, 10 mm
2867-60-550	X-Tab Tab Key
2867-60-500	X-Tab Tab Stabilizer
2867-60-200	X-Tab Derotation Sleeve
2867-60-210	X-Tab Tab Breaker
2867-60-250	X-Tab Neuromonitoring Sleeve
2867-65-050	X-Tab Implant Tray
2867-65-100	X-Tab Instrument Tray
2867-65-125	X-Tab Stabilizer Storage
2867-65-150	X-Tab Screw Measurement Gauge
2867-05-000	MIS 2-Level Case
2867-05-085	VIPER 2 Implant Tray Lid

SCREWS

MIS Cannulated X-Tab			
Item #	Description		
1867-50-030	MIS Cannulated X-Tab, 5 mm × 30 mm, Ti	1867-75-035	MIS Cannulated X-Tab, 7.5 mm × 35 mm, Ti
1867-50-035	MIS Cannulated X-Tab, 5 mm × 35 mm, Ti	1867-75-040	MIS Cannulated X-Tab, 7.5 mm × 40 mm, Ti
1867-50-040	MIS Cannulated X-Tab, 5 mm × 40 mm, Ti	1867-75-045	MIS Cannulated X-Tab, 7.5 mm × 45 mm, Ti
1867-50-045	MIS Cannulated X-Tab, 5 mm × 45 mm, Ti	1867-75-050	MIS Cannulated X-Tab, 7.5 mm × 50 mm, Ti
1867-50-050	MIS Cannulated X-Tab, 5 mm × 50 mm, Ti	1867-75-055	MIS Cannulated X-Tab, 7.5 mm × 55 mm, Ti
1867-50-055	MIS Cannulated X-Tab, 5 mm × 55 mm, Ti		
1867-60-030	MIS Cannulated X-Tab, 6 mm × 30 mm, Ti		
1867-60-035	MIS Cannulated X-Tab, 6 mm × 35 mm, Ti		
1867-60-040	MIS Cannulated X-Tab, 6 mm × 40 mm, Ti		
1867-60-045	MIS Cannulated X-Tab, 6 mm × 45 mm, Ti		
1867-60-050	MIS Cannulated X-Tab, 6 mm × 50 mm, Ti		
1867-60-055	MIS Cannulated X-Tab, 6 mm × 55 mm, Ti		
1867-70-030	MIS Cannulated X-Tab, 7 mm × 30 mm, Ti		
1867-70-035	MIS Cannulated X-Tab, 7 mm × 35 mm, Ti		
1867-70-040	MIS Cannulated X-Tab, 7 mm × 40 mm, Ti		
1867-70-045	MIS Cannulated X-Tab, 7 mm × 45 mm, Ti		
1867-70-050	MIS Cannulated X-Tab, 7 mm × 50 mm, Ti		
1867-70-055	MIS Cannulated X-Tab, 7 mm × 55 mm, Ti		
1867-75-030	MIS Cannulated X-Tab, 7.5 mm × 30 mm, Ti		

25 mm Reduction X-Tab Polyaxial Screws

Item #	Description
2867-60-200	X-Tab Derotation Sleeve
2867-35-420	Modular X-25 Drivers
2867-60-017	Polyaxial Driver, 25 mm
2867-60-217	Tab Breaker, 25 mm
2867-15-351	3.5 RATIO DRIVER
1867-42-530	MIS 25 mm X-Tab Polyaxial, 5 mm × 30 mm, Ti
1867-42-535	MIS 25 mm X-Tab Polyaxial, 5 mm × 35 mm, Ti
1867-42-540	MIS 25 mm X-Tab Polyaxial, 5 mm × 40 mm, Ti
1867-42-545	MIS 25 mm X-Tab Polyaxial, 5 mm × 45 mm, Ti
1867-42-550	MIS 25 mm X-Tab Polyaxial, 5 mm × 50 mm, Ti
1867-42-555	MIS 25 mm X-Tab Polyaxial, 5 mm × 55 mm, Ti
1867-42-630	MIS 25 mm X-Tab Polyaxial, 6 mm × 30 mm, Ti
1867-42-635	MIS 25 mm X-Tab Polyaxial, 6 mm × 35 mm, Ti
1867-42-640	MIS 25 mm X-Tab Polyaxial, 6 mm × 40 mm, Ti
1867-42-645	MIS 25 mm X-Tab Polyaxial, 6 mm × 45 mm, Ti
1867-42-650	MIS 25 mm X-Tab Polyaxial, 6 mm × 50 mm, Ti
1867-42-655	MIS 25 mm X-Tab Polyaxial, 6 mm × 55 mm, Ti
1867-42-730	MIS 25 mm X-Tab Polyaxial, 7 mm × 30 mm, Ti
1867-42-735	MIS 25 mm X-Tab Polyaxial, 7 mm × 35 mm, Ti
1867-42-740	MIS 25 mm X-Tab Polyaxial, 7 mm × 40 mm, Ti
1867-42-745	MIS 25 mm X-Tab Polyaxial, 7 mm × 45 mm, Ti
1867-42-750	MIS 25 mm X-Tab Polyaxial, 7 mm × 50 mm, Ti
1867-42-755	MIS 25 mm X-Tab Polyaxial, 7 mm × 55 mm, Ti

Cannulated Uniplanar Screws

Item #	Description
2867-05-090	VIPER 3D Case/Tray
2867-05-700	VIPER 2 Ti Uniplanar Caddy
2867-05-085	VIPER 2 Implant Tray Lid
1867-20-530	VIPER 2 Uniplanar Screw, 5 mm × 30 mm, Ti
1867-20-535	VIPER 2 Uniplanar Screw, 5 mm × 35 mm, Ti
1867-20-540	VIPER 2 Uniplanar Screw, 5 mm × 40 mm, Ti
1867-20-545	VIPER 2 Uniplanar Screw, 5 mm × 45 mm, Ti
1867-20-550	VIPER 2 Uniplanar Screw, 5 mm × 50 mm, Ti
1867-20-635	VIPER 2 Uniplanar Screw, 6 mm × 35 mm, Ti
1867-20-640	VIPER 2 Uniplanar Screw, 6 mm × 40 mm, Ti
1867-20-645	VIPER 2 Uniplanar Screw, 6 mm × 45 mm, Ti
1867-20-650	VIPER 2 Uniplanar Screw, 6 mm × 50 mm, Ti
1867-20-655	VIPER 2 Uniplanar Screw, 6 mm × 55 mm, Ti
1867-20-735	VIPER 2 Uniplanar Screw, 7 mm × 35 mm, Ti
1867-20-740	VIPER 2 Uniplanar Screw, 7 mm × 40 mm, Ti
1867-20-745	VIPER 2 Uniplanar Screw, 7 mm × 45 mm, Ti
1867-20-750	VIPER 2 Uniplanar Screw, 7 mm × 50 mm, Ti
1867-20-755	VIPER 2 Uniplanar Screw, 7 mm × 55 mm, Ti

Cannulated Monoaxial Screws

Item #	Description
2867-05-090	VIPER 3D Case/Tray
2867-05-710	VIPER 2 Ti Monoaxial Caddy
2867-20-100	VIPER 2 Monoaxial Driver
2867-05-085	VIPER 2 Implant Tray Lid
1867-17-530	VIPER Monoaxial Screw, 5 mm × 30 mm, Ti
1867-17-535	VIPER Monoaxial Screw, 5 mm × 35 mm, Ti
1867-17-540	VIPER Monoaxial Screw, 5 mm × 40 mm, Ti
1867-17-545	VIPER Monoaxial Screw, 5 mm × 45 mm, Ti
1867-17-550	VIPER Monoaxial Screw, 5 mm × 50 mm, Ti
1867-17-635	VIPER Monoaxial Screw, 5 mm × 35 mm, Ti
1867-17-640	VIPER Monoaxial Screw, 6 mm × 40 mm, Ti
1867-17-645	VIPER Monoaxial Screw, 6 mm × 45 mm, Ti
1867-17-650	VIPER Monoaxial Screw, 6 mm × 50 mm, Ti
1867-17-655	VIPER Monoaxial Screw, 6 mm × 55 mm, Ti
1867-17-735	VIPER Monoaxial Screw, 7 mm × 35 mm, Ti
1867-17-740	VIPER Monoaxial Screw, 7 mm × 40 mm, Ti
1867-17-745	VIPER Monoaxial Screw, 7 mm × 45 mm, Ti
1867-17-750	VIPER Monoaxial Screw, 7 mm × 50 mm, Ti
1867-17-755	VIPER Monoaxial Screw, 7 mm × 55 mm, Ti
1867-17-035	VIPER Monoaxial Screw, 7.5 mm × 35 mm, Ti
1867-17-040	VIPER Monoaxial Screw, 7.5 mm × 40 mm, Ti

1867-17-045	VIPER Monoaxial Screw, 7.5 mm × 45 mm, Ti
-------------	--

1867-17-050	VIPER Monoaxial Screw, 7.5 mm × 50 mm, Ti
-------------	--

1867-17-055	VIPER Monoaxial Screw, 7.5 mm × 55 mm, Ti
-------------	--

Cannulated Long Shank Screws

Item #	Description
2867-05-790	Long Screw Loading Block
2867-05-780	VIPER 2 Long Screw Caddy
2867-05-005	VIPER 3D Long Screw Half Tray
2867-05-045	VIPER 2 Half Tray Lid
1867-15-770	MIS Cannulated Polyaxial Screw, 7 mm × 70 mm, Ti
1867-15-780	MIS Cannulated Polyaxial Screw, 7 mm × 80 mm, Ti
1867-15-799	MIS Cannulated Polyaxial Screw, 7 mm × 100 mm, Ti
1867-15-070	MIS Cannulated Polyaxial Screw, 7.5 mm × 70 mm, Ti
1867-15-080	MIS Cannulated Polyaxial Screw, 7.5 mm × 80 mm, Ti
1867-15-099	MIS Cannulated Polyaxial Screw, 7.5 mm × 100 mm, Ti

GUIDE WIRES

Item #	Description
2867-05-200	1.37 mm Guidewire, Blunt
2867-05-210	1.37 mm Guidewire, Sharp
2867-05-220	VIPER 2 1.45 mm Guidewire, Blunt
2867-05-230	VIPER 2 1.45 mm Guidewire, Sharp

BCK9015	VIPER Jamshidi Needle, (BEVELED, TROCAR & BLUNT TIPS)
---------	---

INDICATIONS AND USAGE

Indications

The EXPEDIUM and VIPER Spine Systems are intended to provide immobilization and stabilization of spinal segments in skeletally mature patients as an adjunct to fusion in the treatment of acute and chronic instabilities or deformities of the thoracic, lumbar and sacral spine.

The EXPEDIUM and VIPER Spine System are intended for noncervical pedicle fixation and nonpedicle fixation for the following indications: degenerative disc disease (defined as back pain of discogenic origin with degeneration of the disc confirmed by history and radiographic studies); spondylolisthesis; trauma (i.e., fracture or dislocation); spinal stenosis; curvatures (i.e., scoliosis, kyphosis, and/or lordosis); tumor, pseudarthrosis; and failed previous fusion in skeletally mature patients.

When used in a posterior percutaneous approach with MIS instrumentation, the VIPER Systems are intended for noncervical pedicle fixation and nonpedicle fixation for the following indications: degenerative disc disease (defined as back pain of discogenic origin with degeneration of the disc confirmed by history and radiographic studies); spondylolisthesis; trauma (i.e., fracture or dislocation); spinal stenosis; curvatures (i.e., scoliosis, kyphosis, and/or lordosis); tumor, pseudarthrosis; and failed previous fusion in skeletally mature patients.

When used for posterior non-cervical pedicle screw fixation in pediatric patients, the VIPER2 System implants are indicated as an adjunct to fusion to treat adolescent idiopathic scoliosis. The VIPER2 System is intended to be used with autograft and/or allograft. Pediatric pedicle screw fixation is limited to a posterior approach.

Contraindications

Disease conditions that have been shown to be safely and predictably managed without the use of internal fixation devices are relative contraindications to the use of these devices.

Active systemic infection or infection localized to the site of the proposed implantation are contraindications to implantation.

Severe osteoporosis is a relative contraindication because it may prevent adequate fixation of spinal anchors and thus preclude the use of this or any other spinal instrumentation system.

Any entity or condition that totally precludes the possibility of fusion, i.e., cancer, kidney dialysis, or osteopenia is a relative contraindication. Other relative contraindications include obesity, certain degenerative diseases, and foreign body sensitivity. In addition, the patient's occupation or activity level or mental capacity may be relative contraindications to this surgery. Specifically, patients who because of their occupation or lifestyle, or because of conditions such as mental illness, alcoholism, or drug abuse, may place undue stresses on the implant during bony healing and may be at higher risk for implant failure.

Warnings, Precautions, and Possible Adverse Effects Concerning Temporary Metallic Internal Fixation Devices

Following are specific warnings, precautions, and possible adverse effects that should be understood by the surgeon and explained to the patient. These warnings do not include all adverse effects that can occur with surgery in general, but are important considerations particular to metallic internal fixation devices. General surgical risks should be explained to the patient prior to surgery.

Warnings

1. **CORRECT SELECTION OF THE IMPLANT IS EXTREMELY IMPORTANT.** The potential for satisfactory fixation is increased by the selection of the proper size, shape, and design of the implant. While proper selection can help minimize risks, the size and shape of human bones present limitations on the size, shape and strength of implants. Metallic internal fixation devices cannot withstand activity levels equal to those placed on normal healthy bone. No implant can be expected to withstand indefinitely the unsupported stress of full weight bearing.
2. **IMPLANTS CAN BREAK WHEN SUBJECTED TO THE INCREASED LOADING ASSOCIATED WITH DELAYED UNION OR NONUNION.** Internal fixation appliances are load-sharing devices which are used to obtain alignment until normal healing occurs. If healing is delayed, or does not occur, the implant may eventually break due to metal fatigue. The degree or success of union, loads produced by weight bearing, and activity levels will, among other conditions, dictate the longevity of the implant. Notches, scratches or bending of the implant during the course of surgery may also contribute to early failure. Patients should be fully informed of the risks of implant failure.
3. **MIXING METALS CAN CAUSE CORROSION.** There are many forms of corrosion damage and several of these occur on metals surgically implanted in humans. General or uniform corrosion is present on all implanted metals and alloys. The rate of corrosive attack on metal implant devices is usually very low due to the presence of passive surface films. Dissimilar metals in contact, such as titanium and stainless steel, accelerate the corrosion process of stainless steel and more rapid attack occurs. The presence of corrosion often accelerates fatigue fracture of implants. The amount of metal compounds released into the body system will also increase. Internal fixation devices, such as rods, hooks, etc., which come into contact with other metal objects, must be made from like or compatible metals.
4. **PATIENT SELECTION.** In selecting patients for internal fixation devices, the following factors can be of extreme importance to the eventual success of the procedure:
 - A. The patient's weight. An overweight or obese patient can produce loads on the device that can lead to failure of the appliance and the operation.
 - B. The patient's occupation or activity. If the patient is involved in an occupation or activity that includes heavy lifting, muscle strain, twisting, repetitive bending, stooping, running, substantial walking, or manual labor, he/she should not return to these activities until the bone is fully healed. Even with full healing, the patient may not be able to return to these activities successfully.
 - C. A condition of senility, mental illness, alcoholism, or drug abuse. These conditions, among others, may cause the patient to ignore certain necessary limitations and precautions in the use of the appliance, leading to implant failure or other complications.
 - D. Certain degenerative diseases. In some cases, the progression of a degenerative disease may be so advanced at the time of implantation that it may substantially decrease the expected useful life of the appliance. For such cases, orthopedic devices can only be considered a delaying technique or temporary remedy.
 - E. Foreign body sensitivity. The surgeon is advised that no preoperative test can completely exclude the possibility of sensitivity or allergic reaction. Patients can develop sensitivity or allergy after implants have been in the body for a period of time.
 - F. Smoking. Patients who smoke have been observed to experience higher rates of pseudarthrosis following surgical procedures where bone graft is used. Additionally, smoking has been shown to cause diffuse degeneration of intervertebral discs. Progressive degeneration of adjacent segments caused by smoking can lead to late clinical failure (recurring pain) even after successful fusion and initial clinical improvement.

Precautions

1. **SURGICAL IMPLANTS MUST NEVER BE REUSED.** An explanted metal implant should never be reimplanted. Even though the device appears undamaged, it may have small defects and internal stress patterns which may lead to early breakage. Reuse can compromise device performance and patient safety. Reuse of single use devices can also cause cross-contamination leading to patient infection.
2. **CORRECT HANDLING OF THE IMPLANT IS EXTREMELY IMPORTANT.** Contouring of metal implants should only be done with proper equipment. The operating surgeon should avoid any notching, scratching or reverse bending of the devices when contouring. Alterations will produce defects in surface finish and internal stresses which may become the focal point for eventual breakage of the implant. Bending of screws will significantly decrease the fatigue life and may cause failure.
3. **CONSIDERATIONS FOR REMOVAL OF THE IMPLANT AFTER HEALING.** If the device is not removed after the completion of its intended use, any of the following complications may occur: (1) Corrosion, with localized tissue reaction or pain; (2) Migration of implant position resulting in injury; (3) Risk of additional injury from postoperative trauma; (4) Bending, loosening, and/or breakage, which could make removal impractical or difficult; (5) Pain, discomfort, or abnormal sensations due to the presence of the device; (6) Possible increased risk of infection; and (7) Bone loss due to stress shielding. The surgeon should carefully weigh the risks versus benefits when deciding whether to remove the implant. Implant removal should be followed by adequate postoperative management to avoid refracture. If the patient is older and has a low activity level, the surgeon may choose not to remove the implant thus eliminating the risks involved with a second surgery.
4. **ADEQUATELY INSTRUCT THE PATIENT.** Postoperative care and the patient's ability and willingness to follow instructions are among the most important aspects of successful bone healing. The patient must be made aware of the limitations of the implant, and instructed to limit and restrict physical activities, especially lifting and twisting motions and any type of sports participation. The patient should understand that a metallic implant is not as strong as normal healthy bone and could loosen, bend and/or break if excessive demands are placed on it, especially in the absence of complete bone healing. Implants displaced or damaged by improper activities may migrate and damage the nerves or blood vessels. An active, debilitated, or demented patient who cannot properly use weight-supporting devices may be particularly at risk during postoperative rehabilitation.
5. **CORRECT PLACEMENT OF ANTERIOR SPINAL IMPLANT.** Due to the proximity of vascular and neurologic structures to the implantation site, there are risks of serious or fatal hemorrhage and risks of neurologic damage with the use of this product. Serious or fatal hemorrhage may occur if the great vessels are eroded or punctured during implantation or are subsequently damaged due to breakage of implants, migration of implants or if pulsatile erosion of the vessels occurs because of close apposition of the implants.

Refer to the PIPELINE® Access System, SPOTLIGHT® Access System, and CONCORDE® Bullet System surgical technique manuals for additional important information.

